

LIBRARY
OF THE
UNIVERSITY OF CALIFORNIA.

Class









20' X 120' STAND-PIPE, ST. AUGUSTINE, FLA.

Frontispiece.

TOWERS AND TANKS

FOR

WATER-WORKS.

*THE THEORY AND PRACTICE OF THEIR
DESIGN AND CONSTRUCTION.*

BY

J. N. HAZLEHURST,

*Member of the American Society of Civil Engineers; Member of the Society for Municipal
Improvement; Member American Water-works Association.*

THIRD EDITION, REVISED AND ENLARGED.

FIRST THOUSAND.



NEW YORK:

JOHN WILEY & SONS.

LONDON: CHAPMAN & HALL, LIMITED.

1907.

TJL 489
H 9
19

GENERAL

Copyright, 1901, 1904,

BY

J. N. HAZLEHURST.

ROBERT DRUMMOND, PRINTER, NEW YORK.

INTRODUCTION.

It is a strange fact to chronicle that, amongst the great mass of scientific literature, there is no distinct treatise upon the design and construction of metallic receptacles or structures whose province it is to retain a sufficient reserve supply of water, elevated to a proper height and intended to be used in conjunction with other necessary features of a modern water-supply system. Such structures, generally termed "tanks," "water-towers," "stand-pipes," or "towers and tanks," according to their design, are rapidly increasing in number, and are being generally specified in the smaller water-plants, where the economies are to be practised and natural and suitable elevations are unattainable. The popularity of this class of reservoir being on the increase, it would seem that along with the many exhaustive and elaborate discussions of kindred subjects, as hydraulics, hydrostatics, statics, stress, and the metallurgy and physical properties of structural steel, there might be found some work dealing with this now important subject, but so far as the writer is aware, in the entire range of such productions, only the most fragmentary articles are to be found.

The inability to procure definite or reliable information upon the design and construction of such work is probably the cause of the scanty and meagre instructions frequently appearing in sets of specifications for water-works construction, and the deficiency in this respect has been, commented upon by a prominent member of the profession in the following terms:

“The custom has been, to a greater extent than in any other engineering work of like importance, to buy a stand-pipe much as a barrel of flour would be bought; the contract or agreement would be for a stand-pipe so high and so wide, the material and workmanship to be first class in every respect.”

Without previous experience, and unable to secure any degree of exact information as to the best practice for stand-pipe design, it would be amusing, if not so serious a matter, to compare the emaciated paragraph, its stock phrases and blanket clauses, so lax that any “rule-of-thumb” boiler-maker can safely provide almost anything in the shape of a tank, provided it holds together and does not leak too badly, with the plethoric clause, wasting much good paper and printer’s ink in padding the specifications to give an important appearance to the technical description dealing with requirements for “cast-iron pipe,” which probably gets its first inspection when the pressure is applied from the pumping-engines.

Observing this condition of affairs, and having experienced personally the difficulties to be encountered in securing data for work of this sort, during the year 1901 the writer published the first edition of this volume. Its reception seemed to show a reason for its appearance and a demand for a second edition. Profiting by the criticisms of the first venture, eliminations have been made, typographical and other errors have been corrected; the work throughout has been largely revised and rewritten and many new illustrations have been added. The new matter includes a record of stand-pipe failures, continuing from the time of Prof. Pence’s monograph to the present; a comprehensive chapter dealing with the stresses in a steel water-tower, originally presented in the “Technograph,” and revised and rewritten by its author for this work; also two chapters upon the subject of Specifications for and the Architectural and Ornamental possibility of Water-tower Design.

Necessarily a great portion of such production as this must

be compiled from the experience and work of others, and to all who have thus contributed the author desires and has intended to give due credit.

Without further explanation, this second edition of the original work is offered for what it is worth, and the hope is expressed that it may prove of some service.

CONTENTS.

INTRODUCTION.	PAGE iii
-----------------------	-------------

CHAPTER I.

HISTORICAL: EXPLANATORY AND STATISTICAL.	I
Brief Mention of Ancient and Modern Works—Methods of Distribution—Reservoir System Discussed—Introduction of Metallic Reservoirs—Present Extent and Character—Excentricity of Design—Tendency of Modern Practice—Record of Failures.	

CHAPTER II.

THE CHEMICAL AND PHYSICAL PROPERTIES OF STRUCTURAL METAL.	32
Wrought Iron—Physical Difference between Iron and Steel—Effect of Heating—Bessemer Steel—Open-hearth Steel—Effects of Phosphorus—Manufacturers' Standard Specifications—Work of International Association.	

CHAPTER III.

STRUCTURAL METALS.	50
The Use of Iron—The Change to Steel—Classification of Failures—Relative Merits—Comparative Cost—Comparative Homogeneity and Strength of Bessemer and Open-hearth Steels—Suitable Grades for Structural Work—Distinguishing Terms—Chemical Specifications—Inspection.	

CHAPTER IV.

	PAGE
STRESS OR STRAIN, AND STABILITY OF STRUCTURE.....	79
Moment of Forces—Equilibrium—Resistance to Overturning— Wind-pressure — Hydrostatic Pressure — Resistance Offered by Material.	

CHAPTER V.

MECHANICAL PRINCIPLES.	100
Stresses—Bending and Resisting Moments—Modulus of Elasticity— Radius of Gyration—The Gordon Formula for Strength of Columns— Straight-line Compression Formula.	

CHAPTER VI.

THE STRESSES IN A STEEL WATER-TOWER.....	109
Gravity Stress — Nomenclature — Stresses in the Cylinder— Stresses in the Cone—Stresses in the Segment of a Sphere— Stresses in the Joint Between the Bottom and the Cylinder— Stresses in the Circular Girder—Stresses in the Posts—Stresses Resulting from the Horizontal Thrust at the Top of the Posts— Stresses in Ring at Top of Posts—Horizontal Stresses in Plane of Change of Inclination of Posts—Horizontal Stresses at the Base of the Tower—Wind-stresses—In Cylinder—In Tower—Loads on the Foundations—Conclusions.	

CHAPTER VII.

RIVETING.	142
Efficiency of Riveted Joint—Single-riveted Joint—Double-riveted Joint—Triple-riveted Joint—Double-welt Butt-joint—Pitch of Rivets —Size of Rivets in Relation to Thickness of Plates—Rivet Sizes and Spacing for Structural Work.	

CHAPTER VIII.

DESIGNING.....	162
Strain-sheet—Application of Mechanical Principles—Thickness of Plate—Joint Efficiency—Bed-plate and Connection—Details— Method of Anchorage.	

CHAPTER IX.

	PAGE
DESIGNING—CONTINUED.	177
General Considerations—Fairhaven Failure—Consideration of Tank Bottom and Connections—The Circular Girder—Supporting Tower—Tank Cover—Trolley Rail—Ladder—Balcony—Supply Pipe—Frost-proofing—Connections—Wind-bracing—Anchorage—Graphic Design—Estimating Quantities—Stress in the Girder—Wind Stress in the Girder—Tortion Moment—Horizontal Reaction at the Top of Posts—Overturning Moments at Point of Support—Tension in the Joint Between the Bottom and the Cylinder—Stress and Section of Tower Members—Bearing-plates—Stability of Structure and Anchorage.	

CHAPTER X.

FOUNDATIONS.	220
Explanations—Rock—Clay—Dry Sand—Quicksand—Increasing Bearing Values—Stone Masonry—Rankine's Rule—Brick Masonry—Concrete Foundations—Maximum Pressures—Designing Foundations, including Anchorage and Capping.	

CHAPTER XI.

PAINING.	243
Discussion—Iron Rust—Chemical and Galvanic Action—Mill-scale—Cleaning the Metal—Zinc coating—"Oxidized" Plates—"Japanned" Plates—Practical Considerations—Paint-films—Linseed-oil—Pigments—Red Oxide of Lead—Asphaltic Varnish—Application—Repainting—Protective Coverings for Iron and Steel—Average Surface Covered per Gallon of Paint.	

CHAPTER XII.

SHOP PRACTICE AND ERECTION.	270
Laying Out Work—Machining—Punching and Rolling—Shop Assembly—Cleaning and Priming—Preparation of Foundations—Preliminaries to Erection of Stand pipes—Field Assembly—Inspection—Erection of Towers and Tanks—Field-riveting—Machine-driven Rivets.	

CHAPTER XIII.

	PAGE
SPECIFICATIONS.	289
General Discussion—Suggested Form for Steel Water-tower— Details—Materials—Inspection—Stresses—Shop Work—Field As- sembly—Test—Painting—Delay in Completion—Recommendations.	

CHAPTER XIV.

ARCHITECTURE AND ORNAMENTATION.	310
Opportunity for Architectural Effect—Tendency Toward Orna- mentation—The True and Beautiful in Architecture—Incongruous Architecture—Competitive Water-tower Designs—Recent Examples of Ornamented Water-towers—The Possibility of Architectural Effect in Structural Metal Design—Conspicuous Examples.	



TOWERS AND TANKS FOR WATER-WORKS.

CHAPTER I.

BRIEF MENTION OF ANCIENT AND MODERN WORKS.

AMONGST the earliest evidences of a prior civilization, ruined aqueducts, varying in design and extent, indicate the appreciated necessity of public water-supply for populous communities. During the reign of the Jewish King, Solomon, extensive reservoirs or pools were designed and constructed, which to the present time bear his name and testify to the wisdom accredited him, continuing, after the lapse of ages, to deliver a supply of pure water to the citizens of Jerusalem.

The important works constructed under the Cæsars present a good example of the excellence attained by the hydraulician and the general requirements in the matter of water-supply of that day, whilst in the New World, amid the wreck of a more remote antiquity, are to be found examples of the genius of that mysterious race, the Aztec, and its application toward the development of this most important factor in the progress of nations.

Recognizing and putting into practical use the principles of the great natural law of the flow of liquids impelled by gravity, convenient mountain streams and brooks were impounded and led down the hillsides by open channels or aqueducts for the convenience of the people.

In scope such works were necessarily limited by topographical conditions, and permitted only the application of the principles governing what is to-day known as "The Gravity System."

For centuries this method of water-distribution prevailed, varied and modified to suit different conditions, but being shorn from time to time of original crudities, and participating in the general advance toward a higher civilization, the system has reached a high degree of efficiency.

The wonderful advancement of the present epoch in scientific knowledge and mechanical development has made possible the economical production and transmission of power, along with which has come the knowledge of, necessity for, and advantage to be derived from the employment of mechanical means and methods for the accomplishment of required results by other than the primitive principles of gravity flow.

The reference to advantages to be derived from the employment of artificial methods as applied to water-distribution, rather than the utilization of natural agencies, is relative, and is intended to apply only to a broadening of the possibilities; for in the consideration of the question of general or particular source of water-supply, the first investigation should deal with the possibility of procuring a gravity flow, and all subsequent propositions should be referred to the cardinal principle and initial hypothesis that for economy, efficiency, and consequent desirability, Nature's methods take precedence over mechanical means.

Methods of Distribution.—Since the application of scientific methods to natural forces, the problem of water-distribution may be broadly separated into three general schemes or systems—"The Gravity," "The Reservoir," and "The Direct"—each showing particular advantage in individual cases.

Of the first of these, for the purposes of this discussion, possibly enough has been said.

The second, under a multiplicity of design, has for its object the mechanical elevation of water from a lower to a higher level, and its storage in basins or reservoirs of sufficient size and elevation to answer all of the requirements.

The third, or "Direct," scheme distributes the water by a constant, applied mechanical pressure to the contemplated points of delivery. In this monograph, a subdivision of the second of these broad methods will be discussed, as its scope is intended to cover the architectural design; materials and methods of constructing and erecting elevated storage-reservoirs, which of late years have played an important part in the general economy of most water-works designs.

Reservoir System Discussed.—The detail of such construction is subject to local condition, and ranges from designs for small tanks elevated upon supporting columns to immense reservoirs for the water-supply of great cities. In the general scheme of a water-supply system the elevated reservoir serves a dual purpose; providing for a surplus supply to be utilized as required, as well as permitting a temporary suspension of the mechanical operations of the plant; its further purpose is its ability to relieve internal pressures, acting in this capacity as a regulator or relief-valve to the entire system of distribution. Considered simply as a receptacle for elevated storage, its purpose and principles are obvious.

In the natural exercise of the functions of an automatic safety-valve, the results are similar to those produced by an air-chamber, closely connected to the pumping machinery. The force exerted in the intermittent action of an enclosed column of water compressed or impelled by the forward movement of the pistons or plungers of the pumping-engine, acts as a "ram," producing rupture, according to the intensity of the force exerted, to pipe-mains, connections and joints. This stress may be relieved and the shock regulated by providing for a discharge of the water under pressure into an

open reservoir whose upper or highest elevation shall be somewhat in excess of the height to which the water would naturally be forced under the stress conditions, otherwise the reservoir will overflow.

Whilst this destructive tendency has been greatly lessened by the use of improved duplex pumping machinery, there is also to be considered in the economy of operation a certain loss of energy due to the force necessary to put in motion the column of water, temporarily suspended at the expiration of each forward stroke of the machinery by the rigid enclosing sides of the pipe-lines. Connections to an open reservoir provide an opportunity for escape and permits an onward movement of the liquid column, relieving the "back pressure," and, through its own momentum, effecting a saving in energy necessary to impel it forward. The relief to the pipe system is to the same extent enjoyed by the pumping machinery, reducing the strains upon the mechanism and the consequent number and extent of repairs, and, more important still, the liability to accident at some critical moment. Any open reservoir or vertical pipe, of whatever diameter and of sufficient height, will afford the desired relief, but it is the usual practice to couple with this desideratum a capacity sufficient for a reserve supply.

The accomplishment of these requirements is generally secured for the larger cities by reservoirs of earth and masonry construction for reasons of economy and permanency, and designed to suit topographical conditions and local demands.

For the same reasons, in all preliminary investigations for the water-supply of the smaller cities and towns, elevated sites suitable for similar construction should be sought and first given careful consideration.

The subject of the theory, details, and construction of such reservoirs has been discussed by such eminent authorities, and so great a volume of scientific and prolix literature has been

devoted to its consideration, that no attempt will be made here to introduce original conclusions, owing to the unlikelihood of the author being able to add anything worthy of receiving consideration.

Introduction of Metallic Reservoirs in the United States.—

The historic record of the introduction of metallic reservoirs, if procurable, would be of much general interest, but unfortunately such information is of the most meagre and unsatisfactory character; of more or less doubtful authenticity.

The oldest complete water system installed in the United States is believed to be that erected at Bethlehem, Pennsylvania, in 1754-61, by Hans Christopher Christiansen, at which point two stand-pipes have at different times been constructed. The first of these, a tank 40×24 ft. with a capacity of 225,000 gallons, having served its term of usefulness, was abandoned, and a new steel structure replaces it.

Mr. R. E. Neumeyer, superintendent, writes that for some time he has been engaged in procuring data as to the history of this plant, and this he intends giving publicity later, which, it is to be hoped, he will.

In a recent volume of the *Engineering News* there appears a brief article mentioning a stand-pipe erected in the city of New York, by or through the instrumentality of Aaron Burr, in connection with the launching of the Manhattan Company, a banking house, chartered 1799, and in existence at this time. The tank is described as about 35 ft. in diameter by 15 ft. in height, composed of segmental courses of iron castings, with flanged and bolted joints. Each segment is $2\frac{1}{2}$ ft. wide by 5 ft. high, re-enforced by a web, midway, the flanges at the joints being also re-enforced by web angles. An ornamental effect is obtained by beads forming panels on each half of the outer facings of the segmental castings. Four iron hoops are placed around the tank, and the structure is supported by a masonry tower some 15 or 20 ft. in height.

The supply-pipe is 20 ins. in diameter, and is provided with a gate, enclosed in a rectangular chamber, formed by bolting together two flanged iron castings. The following has been subsequently obtained through correspondence:

“Referring to the tank concerning which you make enquiry, and upon the preservation of which is by some erroneously attributed our existence as a corporation, I beg to say in reply to your request for information, that we are unable to furnish any, as the property upon which the tank is situated is, and has been, leased for many years.”

According to a compilation of statistics published by “The Manual of American Water-works,” for 1897, there are in the United States 3215 complete municipal water-supply plants. Of these 2223 are designed for gravity supply from earth or masonry reservoirs or impounding basins, small wooden tanks, or intended to be operated entirely by direct pressure.

Their Present Extent and Character.—Nine hundred and ninety-two works are equipped with some form of elevated metallic storage-tanks or reservoirs, approximately 30 per cent. of the entire number of plants, whilst 535, or about 50 per cent. of these last have been erected since 1890, the figures pointing clearly along what lines advanced practice in water-works design is tending.

The accompanying table, compiled from the “Manual” for '97, shows to what extent each State has adopted metallic reservoirs, their average diameter and height, and a record of the material used in the construction as far as given. A column of low, or domestic, pressure, and one showing the fire, or emergency, pressure is also added. The summation and average of the columns of figures given is interesting in its indication of the general practice and requirements deemed necessary, and from which the composite stand-pipe is 20.2 ft. in diameter, with a height of 62.7 ft., capable of containing

TABLE NO. I.
STAND-PIPE STATISTICS.

Name.	Number	Diam-eter.	Height.	Steel.	Iron.	Low Pres-sure.	High Pres-sure.
Maine.....	21	28	59	8	65	99
New Hampshire...	8	27	66	2	63	86
Vermont.....	2	32	33	2	80
Massachusetts....	54	31	69	7	22	63	90
Rhode Island.....	9	30	71	4	75	84
Connecticut.....	4	39	65	1	3	57	85
New York.....	74	23	79	19	18	65	101
New Jersey.....	44	20	95	4	13	51	82
Pennsylvania....	50	21	81	3	4	70	100
Delaware.....	4	12	88	2	48	108
Maryland.....	10	16	90	1	2	60	94
District Columbia.	none
Virginia.....	9	23	67	6	2	91	108
West Virginia....	15	35	49	3	2	95	127
North Carolina...	10	20	100	5	2	47	109
South Carolina...	8	16	96	2	4	43	114
Georgia.....	15	19	89	7	4	59	82
Florida.....	7	19	100	3	3	63	117
Alabama.....	12	20	95	3	3	78	112
Mississippi.....	6	21	95	3	3	58	106
Louisiana.....	10	14	120	5	3	45	100
Tennessee.....	8	20	120	5	1	63	101
Kentucky.....	13	23	104	3	6	62	100
Ohio.....	54	21	102	27	11	64	108
Indiana.....	24	17	100	8	3	60	92
Michigan.....	23	21	80	6	6	56	101
Illinois.....	60	14	105	23	3	52	107
Wisconsin.....	20	20	100	7	4	64	113
Iowa.....	34	14	89	17	5	53	108
Minnesota.....	12	18	88	6	1	60	130
Kansas.....	38	15	108	8	10	60	118
Nebraska.....	46	13	90	14	9	55	122
South Dakota.....	4	16	90	1	65	130
North Dakota.....	none
Wyoming.....	none
Montana.....	1	25	50	65	110
Missouri.....	30	14	97	7	6	60	110
Arkansas.....	18	18	104	2	3	60	100
Texas.....	59	17	100	18	12	51	118
Colorado.....	5	23	73	1	62	102
New Mexico.....	none
Arizona.....	1	14	100	45	60
Washington.....	3	15	75	1	38	152
Oregon.....	none
*California.....	3	26	87
Utah.....	none
Idaho.....	1	15	80	1	85	85
Oklahoma.....	2	11	127	2	67	112

* Many of wood.

150,686 U. S. gallons of water. The average normal pressure is found to be 62.1 lbs. per sq. inch along the distributing system, and this pressure is increased in times of emergency to 104 lbs.

The pressure 62.1, under daily conditions, is equivalent to 143.5 ft. head, therefore the typical stand-pipe has been erected upon some convenient elevation 80.8 ft. above the general points of distribution. These figures have a peculiar interest in that the pressures determined represent those secured by actual design, independent, as is frequently the case with earth and masonry dams and reservoirs, of natural locations. It should be remarked that the compilation includes, under the head of stand-pipes, only cylindrical metallic structures, unsupported except by foundations, but all such have been incorporated in the summation and average, whether intended for storage, regulation, or both combined.

Eccentricity of Design.—In the compilation of the foregoing table, the author was much interested in the special features of individual stand-pipes and tanks, where considerable eccentricity and lack of uniformity exists, as will be shown by the following two examples:

The tank of greatest capacity to this date in the United States is that erected at Greenwich, Conn., designed by Mr. Wm. S. Bacot, C.E., and erected in 1889 at a cost of \$12,000, including painting and foundations. This tank is of wrought iron, of 45,000 lbs. specified tensile strength. It is 80 ft. in diameter by 35 ft. in height, and is capable of containing 1,319,472 U. S. gallons. The thickness of plates composing the tank are as follows: bottom, $\frac{5}{16}$ in.; the 1st ring is $\frac{1}{2}$ in. and the top rings $\frac{1}{4}$ in. iron. The joints are fastened with butt-straps. The structure is erected upon a concrete foundation, presumably without anchorage.

In comparison with this colossus, may be cited a stand-pipe designed and erected in 1876, at Winona, Minnesota,

by Mr. George C. Morgan, C.E. This stand-pipe is a steel cylinder, 4 ft. in diameter by 210 ft. in height, capacity 20,000 gallons. It is enclosed in an outer ring of stone and brick masonry, with a 28-in. annular space. The lower 50 ft. is composed of $\frac{1}{2}$ in. steel plate; the upper rings not stated. The pipe rests upon 18 ft. depth of solid masonry, and the entire construction is supported by timbers arranged to form a platform 24 ft. square, resting upon a sub-foundation of water-bearing sand and gravel.

Of the stand-pipes recorded, 228 are constructed of steel, and 195 of iron, the remaining number uncertain.

Besides the usual form of stand-pipes and tanks, there are many towers and tanks, combination affairs, designed to meet certain conditions where it may seem preferable to carry the effective head of water by open structural supports, rather than by utilizing the lower plate-rings of the shell to enclose the sustaining water-column. These supporting towers are of manifold design and construction, being built sometimes of wood, but more frequently of stone or brick masonry, latterly largely of metal.

Tendency of Modern Practice.—In this connection, the “Manual” editorially says:

“In the design of elevated tanks, curved bottoms have recently been used in a number of instances, and steel supporting towers or trestles are now commonly employed. The elevated tank is now preferred by many engineers to the stand-pipe, it being recognized that in many instances the effective upper 20 or 30 ft. of water can be supported more cheaply, and perhaps safely, by a trestle than by a body of water enclosed in a cylinder. Where high hills are available for sites, and storage is quite as important as pressure, stand-pipes have advantages of their own.”

From compilations by the writer, the number of towers and tanks at this time in the United States, utilized by city

water-plants, is 161, generally constructed since 1890. The modern practice is to build them largely of structural or soft steel, and although the procurable data is not so full or complete as the records of stand-pipes in the United States, the general average diameter, height, and capacity is as follows: Diameter, 21.3; height, 36.9; capacity, 101,100 U. S. gallons, supported upon some form of trestle or tower 63.5 ft. On account of temporary service and liability to accident, wooden trestles are now rarely used; stone and brick masonry, although formerly much employed, has recently, on account of cost, been supplanted by metallic towers, principally of steel.

Possibly one of the best modern examples of the tendency toward the erection of the elevated steel tower and tank is that lately constructed at Jacksonville, Florida, at a cost of \$10,000, from designs by Superintendent R. M. Ellis, C.E., 1898. This tank is 30 by 45 ft., with conical bottom and cover, surrounded by an ornamental balcony about its base. The tank is supported by 10 6-in. "Z"-bar columns, 100 ft. in height, stiffened with 8-in. "I"-beam ties, and the usual diagonal tie-rods. The steel in the columns is specified to have a tensile strength of 70,000 to 75,000 lbs.; elastic limit 40,000 lbs., with an elongation of 20 per cent. in 8-in., and a reduction at fracture of 40 per cent.

Steel for the tank, straps, rods, and rivets is to be of 60,000 lbs. as a maximum and 56,000 lbs. as a minimum tensile strength; 25 per cent. elongation in 8-in., and 50 per cent. reduction at point of fracture.

No chemical requirements have been made. The joints are made by butt-strap, and the usual requirements for shop-practice and field-work are insisted upon.

On account of the importance of this structure and its close likeness to the notable tank whose failure at Fairhaven, Mass., has given rise to much discussion, and hereinafter mentioned

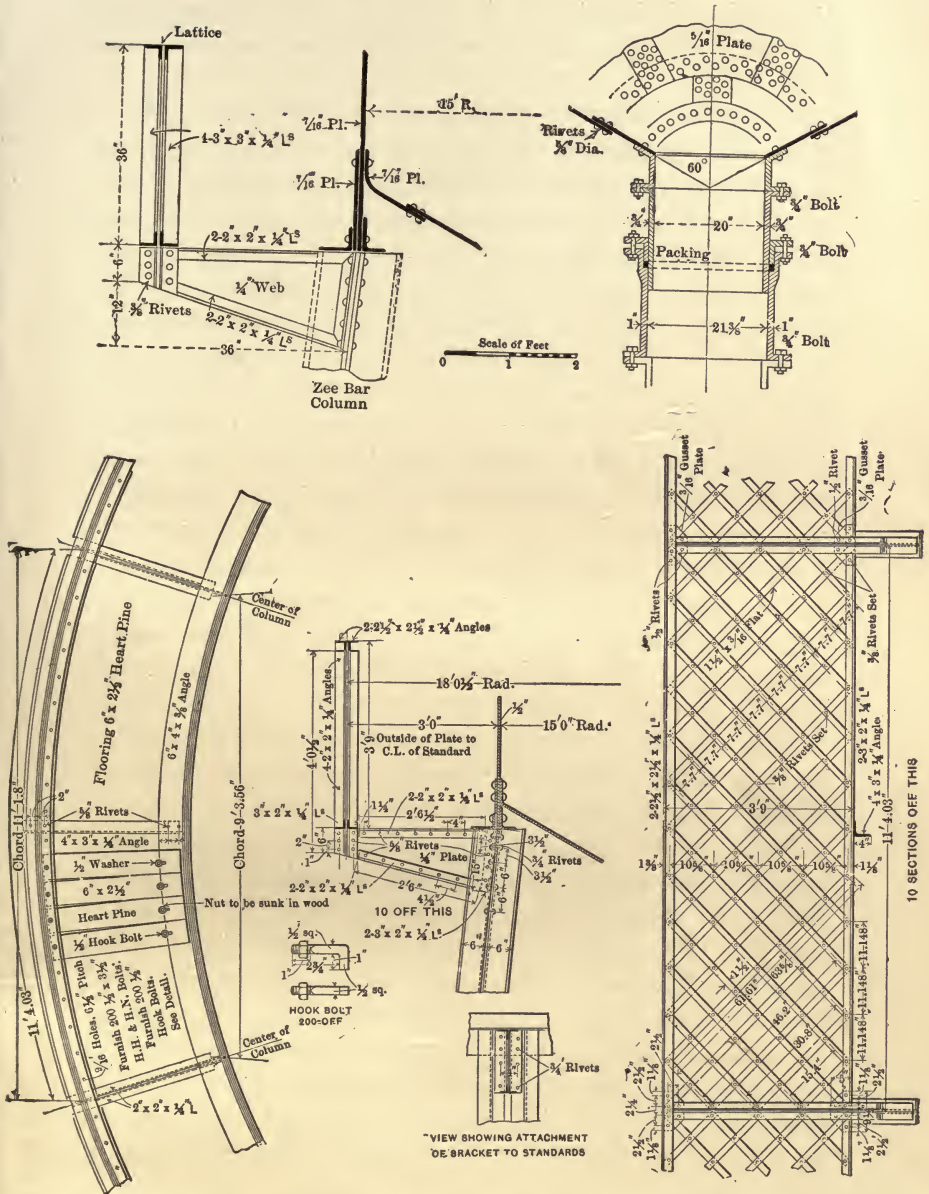

FIG. 1.—TANK DETAILS WATER-TOWER AT JACKSONVILLE, FLA.

at considerable length, for the purpose of comparison and for general information, the Jacksonville, Fla., water-tower is shown in detail.

Record of Failures.—During the year 1894, Prof. W. D. Pence, M. Am. Soc. C. E., published his monograph, "Stand-pipe Accidents and Failures," comprising a record of such occurrences from the earliest procurable data to the time of publication, and a careful investigation of the facts from every procurable source, systematically classified in convenient form and concluding with a general discussion concerning current practice of design, material, and construction. These studies are of great value and interest and comprise the history of 45 accidents to stand-pipes, of which 23 were total wrecks, 14 were slightly damaged, and 8 were partially injured. As far as determined, the cause of the accident was in 22 cases due to water; in 11 cases water and ice; 11 were reported as due to the wind, while a number of accidents were from failure of foundation.

Of these recorded failures, 7 were small wooden tanks, 19 were of steel, and 9 of wrought iron. For a further study of these failures, their underlying causes, and the lesson taught by each the reader is referred to Prof. Pence's admirable work.

Believing that it would be of general interest that this record be brought up to date, the following contains such facts as the author has been able to gather from many sources:

Griswold, Ia., April 13, 1895.—A few hours after the stand-pipe filled for the first time it began to settle to the northwest and cracks opened between foundation and ground on east side and clay compressed on west side. On emptying as soon as possible the top was found at least 13 inches out of plumb. Foundation concrete, about 7 feet deep, not concentric with foundation and manhole vault of concrete extends 6 feet beyond standpipe, but is virtually part of concrete foundation. Load per square foot 3,600 lbs. The pipe was continued in use. When about half full, leans 12 to 13 inches; full, 16 inches. Dimension

of tank 10×100 feet. Engineers, Andrews & Burnell, Fremont, Neb. Contractors, Fremont Foundry & Machine Co. The latter write that there was nothing the matter with the tank itself, but that the foundations were built over a bed of quicksand, and after filling and during a heavy gale of wind the tank settled 3 feet out of plumb. (*Engineering News*, May 13, 1895.) W. W. Manual, Fremont Foundry & Machine Co.; W. D. Lovell, C.E.

Red Oak, Ia.—Abstract from article in *Engineering News*, April 13, 1895: A 22×100 -ft. stand-pipe built in 1895, after completion and being filled was observed to lean some 30 inches from the vertical. Concrete foundation about 8 feet deep; 25-ft. diameter at base; 22-ft. top, upon clay, hard and uniform when dry, but very soft when saturated. During construction clay was thoroughly water-soaked. This stand-pipe was not placed concentrically on foundation. Load on clay, 2.6 tons per square foot. W. D. Lovell, C.E.

Lena, Ill., Dec. 25, 1895.—Uncomplete masonry tower failed before tank was placed. Upper 20 feet of one side fell. Probably due to green (unseasoned) limestone masonry; rain, followed by freezing weather. (Abstract *Engineering News*, Jan. 16, 1896.) Contractors, U. S. Wind Engine & Pump Co., Batavia, Ill. From the latter: "The tower was designed by the U. S. Wind Engine & Pump Co. to support a 65,000-gal. tank on stone tower, giving elevation to bottom of tank of 100 feet above the water-table.

"The foundation was in heavy, clay soil; an excavation was made 10 feet in depth; width of foundation at bottom 6 feet, and at top 3 feet 6 inches. The main wall was carried up from 3 feet in width at the water-table to 18 inches in width at the top. The tower was about 90 per cent completed when the accident happened.

"The stonework was sublet to a firm of contractors, who commenced operations rather late in the fall. fifty feet of the tower was completed when freezing weather set in. The limestone

was native rock, laid irregularly in 10-in. courses; the mortar was composed of one-half cement and one-half lime, with a fairly good quality of 'Torpedo' sand, laid in the usual proportions of hydraulic cement.

"After 50 feet of this work had been completed, more or less, cool weather was encountered during the first few days of December. About Dec. 15th the work was stopped pending a change in the weather, 85 feet of the tower being then completed.

"On Dec. 23d a sudden thaw set in, accompanied by a driving rain, which lasted all night. The frost came out of the stone and mortar and the rain washed out considerable quantities of soft mortar, and on Dec. 24th a large section of the tower on the south side (the direction from which the rain came) gave way extending down to the 50-ft. mark.

"The cause of the trouble was, in the first place, due to the contractor taking chances in having continued cold weather. Had this been the case for a few weeks, the accident would not have occurred.

"The contractor not being financially responsible, the U. S. Wind Engine & Pump Co. tore down the wall and built it anew in regular courses, 50 feet of stone, and the upper 50 feet of pressed brick, and placed the tank thereon, since which time it has been in satisfactory working order in every particular.

"The tower was completed on the same design so far as the proportions were concerned, except that we used Portland cement in rebuilding. It was also thought best to continue the foundation work down to the solid rock and 15 feet farther. We do not think, however, that this made any difference in the safety of the structure, as the bed of clay was amply sufficient to support superimposed weight, as was demonstrated by examination of the foundations when the second excavations were made; it showed no trace of having settled."

Garden City, Kan., April 30, 1896. During a high wind a 10×130-ft. stand-pipe (material not stated) failed. E. C. Murphy,

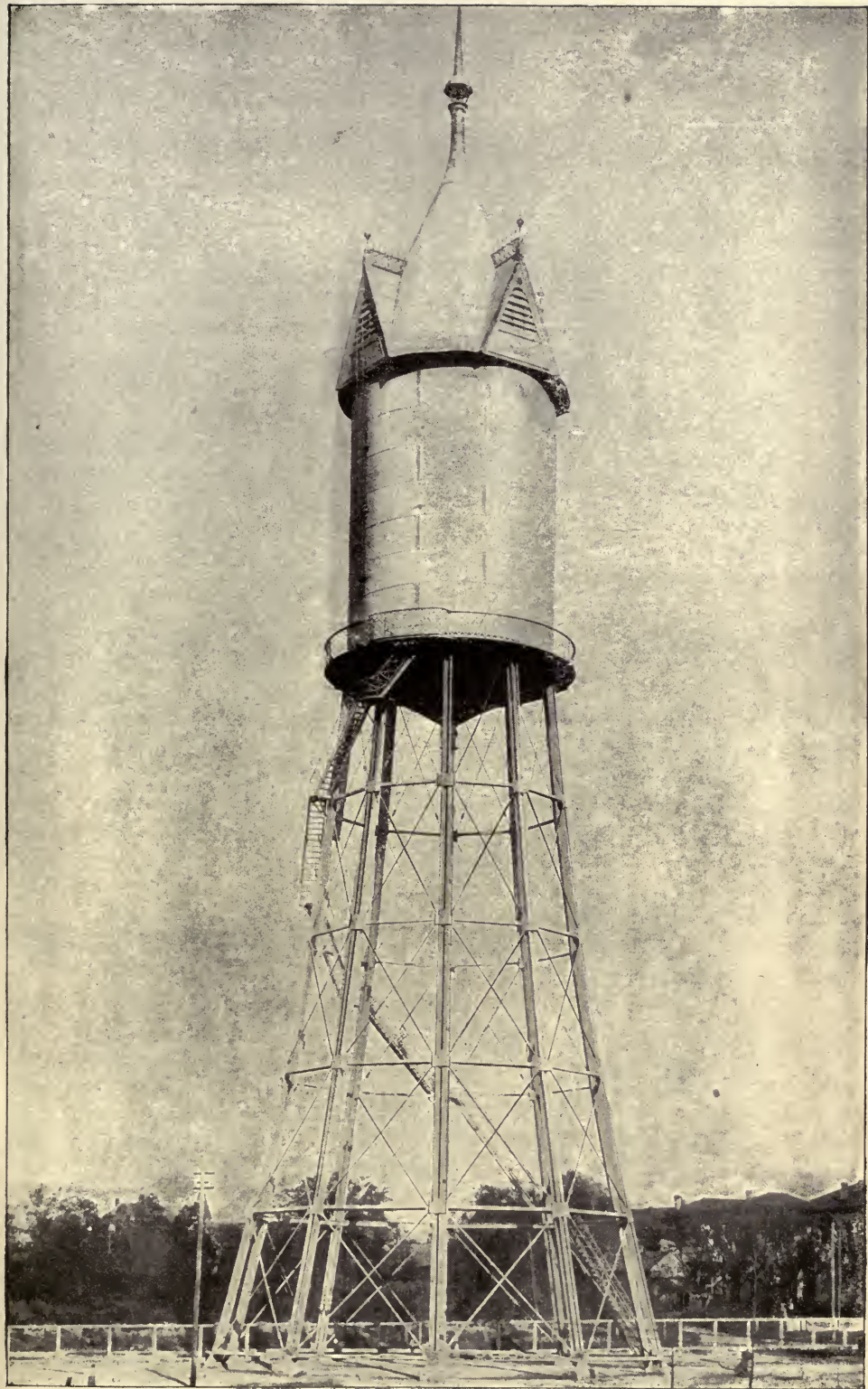

FIG. 2.—JACKSONVILLE, FLA., WATER-TOWER.
R. D. Wood & Co., Philadelphia, builders.

(To face page 14.)



hydrographer, U. S. Geological Survey, Lawrence, Kan., ascribed failure to (1) weak angle iron connecting bottom and first course; (2) cast-iron brackets for securing pipe and foundation not long and strong enough; (3) fastening of guy-rods weak. The angle iron cracked four years after construction, or about 1891, and four of six brackets broke legs. Brackets repaired with strap iron and soldered up. About two and one-half years before wreck, new section of angle iron inserted. At time of wreck, crack appeared on north side of angle iron and increased in size for one and one-quarter hours, until 5 feet long, with water rapidly escaping. Then angle iron (90 feet from base), to which north guy was attached, gave way and pipe fell to southwest. Pipe was then about one-quarter full and both pumps running. The bottom angle broke at the angle all the way round, except where new piece had been inserted, and here the first course of side plates failed along the rivets. All cast-iron brackets broke. (Abstract *Engineering News*, Oct. 1, 1896.) As the local weather observer was not supplied with instruments for measuring the intensity of the wind, its velocity at the time of the accident cannot be ascertained. The material used was wrought iron. Designing Engineer, J. W. Uier, Kansas City, Mo. Contractors, Palmer & Son, Kansas City.

Cortland, N. Y., Sept. 29, 1896. Iron stand-pipe, $\frac{3}{8}$ -in. plate at top indented by wind about its top. Wind, estimated velocity 80 miles an hour; 22 feet of water in tank at time of accident, and extended 2 feet above dented portion of tank. Size 40×40; water-works built in 1884. There was at the time of the accident no angle iron used for stiffening. After the accident the broken plates were removed, the bent portion pulled back to shape with a block and tackle. A patch replaced the broken plate, and an angle iron was riveted inside of the top of the tank. Four steel guys were led over the top of the tank to stone posts firmly set in the ground. (Abstract of *Engineering News*, Nov. 8, 1896.) Wm. B. Landreth, C.E.

Atlantic City, N. J.—About Sept. 12, 1889, 25×132-ft. steel stand-pipe when partly full was considerably damaged by wind blowing at an estimated velocity of 100 miles per hour. The pipe was constructed in 1883. In addition to indentation at top, the tank rocked upon its base, raising several inches on the windward side. There were no leaks and the tank has continued in service. (Abstract *Engineering News*, Nov. 12, 1896.) Kenneth Allen, C.E., Atlantic City, N. J.

Waco, Texas, Oct. 6, 1898.—Stand-pipe, iron, 20×88, failed when full of water and in service. According to the superintendent, the general impression exists that the pipe was maliciously blown up by dynamite. (*Engineering News*, Oct. 20, 1898.) J. P. Sample, Sec., Waco, Texas.

Fairhaven, Mass., Nov. 9, 1901.—This elevated water-tank is particularly notable because the tank was one of the first with a curved bottom ever erected in this country and one of the largest of the type built to this time. The tank was 35 feet in diameter and 50 feet high, with inverted cone bottom for two courses, changing to spherical form for inlet plate. Depth of cone about 12 feet.

The plate of the tank at its connection with circular girder flange was $\frac{1}{2}$ inch, the second section was $\frac{3}{8}$ inch, and the inlet plate was $\frac{1}{4}$ inch thick. The tank was supported by twelve inclined posts surmounted by a 3-ft. girder, from top of same to foundations being 100 feet. Dressed-stone capstones rested upon rubble masonry and were secured by two anchor bolts for each column. The designing engineer was Mr. Freeman F. Coffin, and the structure was built by the Messrs. Ritter-Connelly Mfg. Co., of Pittsburgh, Pa. The tank-plate was originally specified to be of iron, but was subsequently changed to steel, which the manufacturers state was properly inspected and complied with specifications for same.

No subsequent tests of this material were made so far as known, but it is generally agreed that the metal of the shell was very good; that of the bottom fairly good, with one exception;

the butt-straps were of poor and brittle steel, while the tower metal as far as examined was of inferior quality, the fractures



FIG. 3.—VIEW OF WATER-TANK AT FAIRHAVEN, MASS.

(Redrawn from a photograph taken just after the tank was completed. Practically the same view appeared in *Engineering News* for Sept. 5, 1895.)

being “as short as they would be in cast iron, and had a granular appearance.”

The temperature at the time of the accident was about freezing, with no wind.

Eye-witnesses state that there was a sudden burst of water from the tank, followed by its immediate collapse. When the tank reached the ground its conical bottom was almost wholly separated into three parts. The cylindrical portion of the tank was intact around the whole lower ring and showed no signs of failure, except for a few openings in some of the upper joints caused by the shock of falling. The bottom portion of six or seven of the supporting posts fell upon the top of the tank, as did also the two lower lengths, or 40 feet in all, of the 10-in. wrought-iron feed-pipe. The girder and parts which supported the tank were tossed and bent and buried underneath the tank. The foundations, except for the displacement of two or three of the capstones, were unimpaired.

Wherever the bottom and the sides parted in the wreck, with but few exceptions it was the rivets that failed. An examination of the whole circumference of the angle iron attached to the lower edge of the sides of the tank showed only three stretches, $1\frac{1}{2}$, $1\frac{1}{2}$, and 8 feet respectively, where the flange of the bottom plates had ruptured and was still attached to the angle which united the sides and bottom of the tank.

From investigation it was found that three-fourths of the failure was due to rivets and but one-fourth to ruptured plate of the bottom.

The flanged part of the bottom plate was weakened by the counter-sinking for the rivets, yet where the flanged plate tore, the rupture was along the line of the rivet-holes for only two stretches of six rivets each. The rivets, so far as they remained in evidence, failed in their lower or counter-sunk heads; most of these heads pulled right through the bottom plate, the edges of the counter-sunk heads pulling over the end. None could be found which had sheared off. From the original design of this tank, departure was as follows: (1) Substitution of steel for wrought iron in tank and tension members of tower. (2) The flanged bottom of tank was riveted to the angle only, instead

of being riveted to the top of the girder on both sides of the web. (3) The girder was changed from a continuous web for the whole circumference to construction in segments; riveted together at the ends by means of vertical angles. (4) The tank was anchored to the tower by eye-rods. (5) The butt-straps covering the radial joints were placed on the outside instead of on the inside of the tank bottom. The initial rupture was assumed as having taken place at the juncture between the spherical-shaped plate and the inner ring of plates connected with it. In opposition to this theory, reference is made to a full discussion by Prof. Marsden, p. 179. The designing engineer offers the following explanation of the disaster: The failure to rivet the bottom angle securely to the head of the girder as well as to the side angle. A movement was caused by the pressure of the water normal to the bottom, which movement brought an outward pressure upon this girder, which was unsupported except by tensile strength in itself. That is to say, there was an outward pressure on this girder similar to the pressure of the side walls of the stand-pipe and possibly to as great a degree. This pressure would, of course, as in the walls of the stand-pipe, be concentrated at a weak joint, sufficient finally to overcome the comparatively small resistance of one of the joints where the girder was riveted together. This joint failed and the girder was pushed out, or moved from under the bottom at that point, and the weight of the water forced the bottom away from the angle iron by pulling the counter-sunk rivets through the plate. At the same time, the whole tower being weakened at the top, took a twisting motion; the bottom plate fell down and tore off the centre, and the entire structure collapsed. It was believed by the designer that the initial rupture occurred at the sides and not in the centre, as it seemed incredible that the centre plate, even of poor material, could have failed, as the pressure at that point was a minimum and the thickness of the material was ample for the calculated stress. (Abstract

Engineering News, Nov. 21st.) Freeman F. Coffin, C.E., Ritter-Connelly Mfg. Co.

Elgin, Ill.—The 30×95-ft. stand-pipe belonging to the City

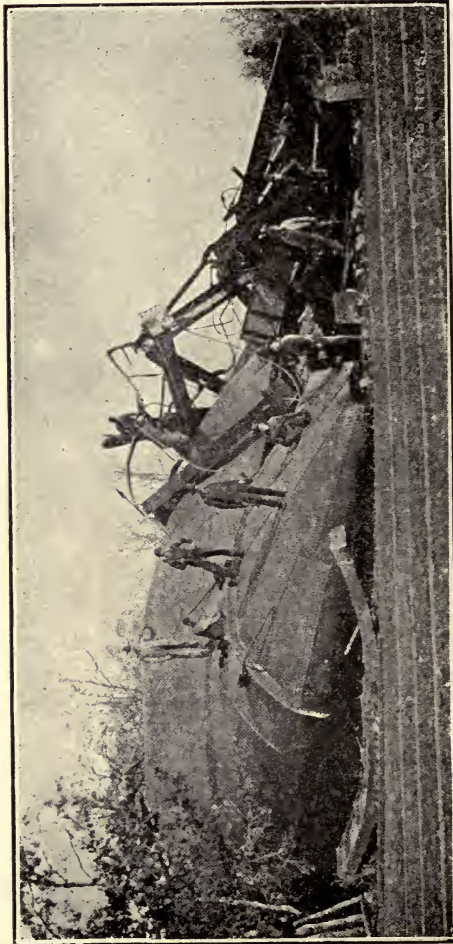

FIG. 4.—VIEW SHOWING PART OF CONICAL BOTTOM AND PART OF TANK PROPER, LOOKING NORTHEAST. (*Engineering News*.)

Water System, constructed in 1887–88, burst on March 14, 1900. Its capacity was 502,300 gals. and the foundation of the

tank was 25 feet high, consisting of concrete, faced with brick masonry.

About 6 A.M. of the day of the accident, the stand-pipe having



FIG. 5.—VIEW OF STAND-PIPE AT ELGIN, ILL., LOOKING NORTHWEST.
(*Engineering News.*)

been pumped full the engines were stopped until 8 A.M., when the failure occurred, during which time the water consumption

was estimated to have withdrawn the water some 20 feet below the top of the tank.

The accident was preceded by a crashing sound due to falling ice, followed by a loud, rending report and the rush of water and ice on the east side, and ending in a rumbling sound as the main upper section, containing several hundred tons of ice, struck the ground. About one-fifth of the plates, consisting of most of the four lower rings, were torn loose from the upper section and from the bed-plate, and were projected by the reaction of the escaping water to the southeast of the foundation, while the upper 75 feet toppled to the east or northeast, falling vertically to the foundations, and landing, a flattened mass, in a north-easterly direction and free from the foundation. An examination of the ruins indicated that the initial rupture occurred on the east or northeast side, about four courses from the base. The holding-down bolts, twenty-two in number, failed mostly in the eye.

Twice each year since the stand-pipe was built it had been emptied and its interior carefully examined. The last inspection was during the previous October, when the stand-pipe was said to have been in satisfactory condition.

No leaking had been reported for at least ten years, but the pitting action of the water was quite marked, perhaps not more so than is usual elsewhere under like conditions. The interior had been repainted twice since the stand-pipe was built, but very little of the interior paint had survived the first winter owing to the friction of the ice. The mean temperature from December to March for six previous years was 21.8°.

For several days preceding the accident the sun had been shining more or less, and there was doubtless some thawing of the ice in the stand-pipe.

It turned cold the evening before the failure and a film of ice $\frac{1}{2}$ inch or more thick formed against the inside of the plates.

From a study of ice fragments, a great tube of ice commonly formed in exposed stand-pipes against the metal shell had in

the Elgin pipe a thickness of 6 inches or so near the bottom and 30 inches or more in the upper section within 30 to 35 feet range of daily fluctuation of water-line. It is commonly the case that the inlet of warm water melts away and prevents the formation of ice shell some distance from the base of stand-pipes, the extent of this action depending chiefly upon the temperature of the water in the mains. Since this had been noted as about 32° previous to the accident, this process of melting the ice must have been very slight in the Elgin pipe. Under these conditions the circulation of water by convection must have been insignificant.

The increase in thickness of the ice walls from the base upward was manifestly due to the increased exposure toward the top. The ice was originally moulded close against the plates and rivets. It was evident, however, that a film of water had formed between the ice and metal shell, probably by action of the sun and warm winds, for some days before the accident, for the impressions of the rivet heads and joints, while perfectly distinct, were not sharply defined. This initial thaw is further evidenced by the thin layer of fresh ice, which clung with surprising adhesion to the inner surface of the plates of the top section notwithstanding its tremendous impact with the frozen ground. Although the $\frac{1}{2}$ -in. film of new ice held thus tenaciously to the metal sheets, no connection could be traced between the fresh film and the fragments of the older ice. A careful examination showed the top of the ice mass in the upper section just even with the upper edge of the top ring of the plates and the imprints of the rivet-heads in the ice near the top continuously matching the rivets themselves, showing that the ice tube had not shifted longitudinally in the metal shell. Since the ice-level was below the point of buoyancy, it is certain that the ice mass was supported top to top with the stand-pipe either by the continuity of the ice shell to the bed-plate, or by a frozen connection between the ice and the plates, or perhaps both. In any event, it seemed absolutely certain that the main bulk of the ice moulded more

or less closely against the stand-pipe plates and did not fall previous to the initial rupture near the base.

Among the countless fragments of ice were a number of very large sheets or chunks, two of which fell upon the bed-plate and another immediately in front of the gate-chamber door. These masses and other boulder-like pieces of almost spherical form had unquestionably floated on the top surface of the water inside the ice tube, forming a broken sheet 30 inches to 3 feet in thickness. With these masses floating at or near the top of the stand-pipe, with the water surface held about stationary for a short time during the previous night, a very slight formation of ice, even less than that found on the plates, would weld them into a self-supporting sheet. The failure of this ice roof with the falling water-level and consequent atmospheric pressure from above, accompanied by the morning rise of temperature, would account for the crashing sound within the stand-pipe heard the instant before the initial rupture occurred. The capacity of the stand-pipe free from ice being about 500,000 gals, the estimated volume of ice, assuming a shell 95 feet high, with 18-inch average walls and a 30-in. top sheet, was 14,190 cubic feet, which would reduce the capacity of the full tank to about 400,000 gals. With the water-level, say, at 72 feet above the base, the volume of water in the pipe when the failure occurred was not far from 300,000 gals. from 6 A.M. to 8 A.M., indicating a consumption of perhaps 100,000 gals. or less during the two hours. The total weight of ice in the stand-pipe, assuming these conditions, was about 400 tons, of which 35 tons was in the top sheet, whose fall is supposed to have preceded the failure.

An examination of the material of which the pipe was composed showed considerable irregularity, many fractures showing more or less dead and laminated appearance and evidence of brittleness, such as cracks and crystalline spots in the fractures. Rivet fractures generally exhibited satisfactory material, although the laying out showed poorly matched holes; there were also signs

of cracks about the rivet-holes, indicating damage in punching brittle plate. Physical tests of samples of the plate were made at Purdue University, as was also a test to determine percentage of phosphorus, with the following results:

Original area in sq. ins.5625	.5754
Elongation in 8, in per cent.	22.5	23.5
Reduction of area, per cent.	47.7	40.5
Elastic limit, per sq. in., lbs.	37,020
Ultimate strength per sq. in., lbs.	58,490	55,960
Character of fracture, coarse, silky; laminated.		

The test for phosphorus was made upon a sample which appeared unusually brittle and had an especially poor fracture. The analysis showed .091% phosphorus.

Examining the list of plate thickness, it appears that the Elgin stand-pipe was designed with a safety factor of 4, assuming 70% joint efficiency with 60,000-lb. steel plate. The spacing and diameter of rivets as found in the lower rings was not such as to give the assumed 70% efficiency. In the fourth ring the rivets had a pitch of about $2\frac{1}{2}$ ins. with 1-in. rivet-holes, which would reduce the efficiency of the joints to 60% and increase the working stress with a full tank from 15,000 to 17,500 lbs. per square inch in the net section. With the water at the 72-ft. level at the time of the accident the stress due to hydrostatic pressure alone was perhaps 13,000 lbs. per square inch in the rings near the base, where the failure occurred. The quite general practice of using a safety factor of 4 in stand-pipe design has doubtless been based upon the assumption of quiescence in the loading, as in building construction. In the case of a stand-pipe properly encased from the action of the ice and wind this assumption is doubtless consistent, although the prevailing practice in good bridgework of using low working stresses for loads frequently applied might warrant the use, even in the protected stand-pipe, of safer unit loads than those obtained with a factor of 4. In any event, the Elgin stand-pipe is open

to severe criticism in that its metal has probably been subjected to as much as 17,500 lbs. per square inch under daily service, which represents a factor of safety of less than 3.5 as compared with the ultimate strength of 60,000 lbs.; or if compared with the elastic strength of say 30,000 lbs. per square inch, a "coefficient of security" of 1.7 or so. The latter is the more correct basis of judgment of the safety of a stand-pipe, since total failure is almost certain to follow the opening up of the rivet-holes, about which cracks or defects are most likely to occur.

The Elgin stand-pipe is, of course, open to the sweeping criticism which may be directed against the large number of stand-pipes which have no protection from the elements, especially those in icy latitudes. If, as must be conceded, intelligent design provides against a dangerous condition, which is certain to exist, then the Elgin stand-pipe was defective in design in that ice could form within it in dangerous quantities. Beside the fall of the ice, other possible dangers from the action of ice have been taken into consideration. One of these is the increased rivet shear due to the possible suspension of 800,000 lbs. of ice from the top rim, which would amount to about 1800 lbs. per rivet. Still another danger was in the formation of the ice-cap by which the rivet shear might be very greatly increased from the atmospheric pressure as the water was drawn off, or the stand-pipe might be overstrained by the sudden starting of the pumps. Should a perfect vacuum form beneath the ice-cap, the increased vertical shear would be about 3300 lbs. per rivet, which, added to that due to the suspended ice, would produce a rivet shear of say 5000 lbs. per rivet above that considered in the design. Still another danger from ice is suggested by the existence of the water film due to thaw against the plates. In case the ice shell had a water-tight connection with the bed-plate, as might appear possible from the low temperature of the supply, and be free from cracks so as to isolate the film from the main body of water, the dangers would be much the same as those which

caused the failures at Asheville, N. C., and Providence, R. I. These conditions are not unlike those which sometimes occur in a refrigerating-plant when a breakdown for a few hours may allow a film of water to thaw between the ice mass and the sides of the freezing-can. Under such circumstances the sides of the cans are sometimes seriously bulged when the refrigeration is resumed. These various possible or probable dangers from ice action merely go to enforce the importance of so encasing stand-pipes as to prevent the formation of ice within them. The opinion of Prof. W. D. Pence, who reported the accident for the



FIG. 6.—GENERAL VIEW OF RUINS OF THE ELGIN STAND-PIPE. (*Eng. News.*)

Engineering News, an abstract of which is here given, is that the accident was probably due to the following causes:

“(1) That the specifications for the Elgin stand-pipe were faulty in the tests for plate metal, and that improper material was used.

“(2) That the working strains in the plate metal were excessive.

“(3) That the failure would probably have occurred even

with first-class material, owing to the exposure of the structure to the elements in the icy latitude.

“(4) That the primary cause of the accident was the fall of



FIG. 7.—VIEW SHOWING EFFECT OF WIND ON STAND-PIPE AT LINCOLN, NEB.
(*Engineering News.*)

ice, due to the improper control of the water-level during the critical ice period.”

Lincoln, Neb.—On April 22, 1902, a 25×100-ft. stand-pipe,

constructed of steel, was badly damaged by the wind with a recorded velocity of from 33 to 60 miles an hour, with an average for five minutes of 57 miles. The pipe was located upon a hill, and the wind had full sweep against it from every side. The stand-pipe was erected upon a concrete foundation of ample strength, and upon which it was observed to rock back and forth during the storm, breaking two anchor rods on the south side, showing a crystalline fracture. All of the rods were found with their nuts off of their heavy batter washers.

The specifications called for the following thickness and weights of plate.

Section, ft. from bottom.	Thickness, in.	Weight per sq. ft., lbs.
Bottom plate	1/2	20.0
1 to 5 ft.	3/4	30.0
6 " 10 "	11/16	28.0
21 " 30 "	5/8	25.0
31 " 40 "	9/16	22.5
41 " 45 "	7/16	17.5
46 " 55 "	3/8	15.0
56 " 65 "	5/16	12.5
66 " 80 "	1/4	10.0
81 " 100 "	3/16	7.5

The other chief features of the specifications were: T. S., 60,000 lbs. per square inch. Vertical seams, D. R., and horizontal seams, S. R. Bottom united to shell by 6 in.×6 in. steel angle; top stiffening ring to be 3½×3½ steel angle securely riveted to plate. Eight anchor-rods, 1¾ inches diameter, securely anchored in concrete foundations and passing through heavy lugs riveted to shell. Plates to be such size that eight plates make a course of 25 feet diameter and twenty courses a height of 100 feet.

The angle stiffening ring was broken in several places. This ring was in sections riveted on the outside of the shell. The joints were butt-joints held by flat plates. The exact amount of water in the tank during the storm's greatest intensity was

uncertain, but was supposed to approximate 60 feet. (*Engineering News*, May 15, 1902.)

Normandy Heights, near Baltimore, Md.—During the latter part of December, 1901, a steel stand-pipe 25×60 feet, belonging to the Roland Parl Co., partially failed. The structure was erected upon a foundation of stone 7 feet high. The stand-pipe was constructed in 5-ft. rings, with thickness as follows: First ring, $\frac{1}{2}$ inch; 3 rings, $\frac{7}{16}$; 4 rings, $\frac{3}{8}$; and 4 rings $\frac{5}{16}$ inch. At a point 52 feet 6 inches above the foundations there was a division in the tank, forming a high-service reservoir 7 feet 6 inches deep. The water main supplying the tower entered at the foundation and extended through the lower section, discharging into the high-service compartment. Beginning near the bottom of this compartment, another pipe was carried to a point near the top of the structure, providing an overflow into the low-service compartment after the high-service tank had been filled. There are few water consumers, and the tank was not pumped into except at intervals of four or five days, thus facilitating the process of freezing during suitable weather such as had existed prior to the failure. Ice had formed to considerable thickness over the surface of the water in both sections of the tank. The inlet pipe was probably also frozen at some point in its length, for when the water was turned on the attendant found that the pipe seemed to be stopped up and proceeded to open a man-hole at the bottom of the tank to draw off the water, intending to build a fire in the lower section to thaw the pipe. He states that a heavy mass of ice, formed at the partition, fell, bending in the braces that supported that partition and high-service compartment, and thus drew the plate in, bending the sheet on one side down nearly to the middle of the stand-pipe. It was suggested that the vacuum produced by drawing off the water was the cause of the trouble, but this theory is hardly tenable, and the attendant's idea as to the cause of the failure is more likely correct. Kenneth Allen, Engineer and Superin-

tendent, Atlantic City, N. J.; Richard W. Marchant, Jr., Baltimore.

A water tower at Abeline, Texas, consisting of a steel tower 70 ft. high, surmounted by a steel tank 25 ft. in diameter by 20 ft. in height, collapsed immediately after completion (April, 1904), an account of which is as follows:

“When the structure was completed, except painting and riveting of a balcony floor, water was pumped into the tank. From the time spent in pumping there was supposed to have been from 16 to 17 ft. of water in the tank, when the entire structure collapsed, falling within its own foundations and making a complete wreck.

“The examination of the wreckage pointed to the weakness of the framework, as the tank came down in one piece, with the bottom split full length, caused, the writer believes, from its contact with the earth, as it appears to have struck on its side. No one witnessed the fall its entire length. Two young men were standing near the tower when they heard a crack, as they explained, like the report of a rifle, and they turned and fled.”

This completes the list of all failures of metal water-towers and tanks to date, although a feature of the past two years has been the many failures of elevated wooden tanks, the great percentage of which failed by the rusting out and subsequent rupture of the flat encircling hoops. To such an extent has this cause resulted in the complete collapse of such structures, that underwriting agencies, who have in many instances specified such structures for fire protection, are now insisting that all hoops shall be made of round rods instead of the flat bands heretofore largely used.

Of the later failures, it will be noted that 3 were due to defective foundations; 4 failed during heavy gales; 2 were damaged by ice formation, and 1 was wrecked simply by hydrostatic pressure.

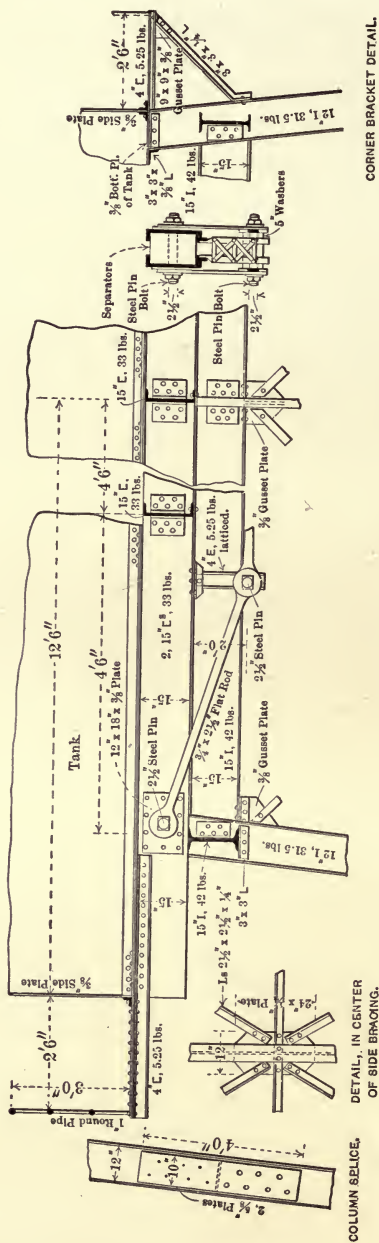

FIG. 3—Some Details from Shep Drawings of Abi enc Tank-tower.

Of the total failures due to wind, ice, and water, 2 were tanks constructed of wrought iron and 4 of structural steel.

After examination, several engineers reported that beside

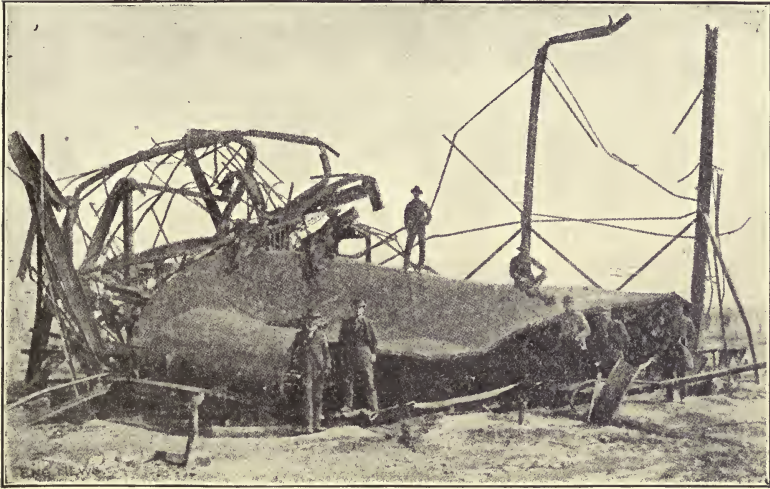

FIG. 1.—View of Wrecked Water Tank-tower at Abilene, Texas.

faulty details of a faulty character, the weakness of the main members, particularly of the floor, was amply sufficient to account for the accident.

CHAPTER II.

THE CHEMICAL AND PHYSICAL PROPERTIES OF STRUCTURAL METAL.

Wrought Iron.—In attempting to discuss the physical and chemical properties of the structural metals, investigation leads by many stages from geological and metallurgical conditions existing in Nature's great laboratory to those finished products daily used in the mechanical arts. Each step in this process of evolution has been given the devoted attention and wisdom of learned scientists, who have contributed to the world the results of their researches in many erudite and voluminous works. It is not within the scope of this volume to do more than attempt to explain certain pertinent features of this complex subject.

In general metallic reservoirs and their supports are constructed of riveted plates and members of iron or steel. Until the last decade iron was almost universally employed, but improved processes of manufacture, reducing at the same time the cost of the product and eliminating the uncertainty of the result, has produced a radical change in this practice, until steel has attained first place as a suitable metal for structural purposes.

In the production of wrought iron, the chemical process is the conversion of crude or "pig" iron into a refined or "merchantable" product by recarburization in a "puddling furnace." For the manufacture of wrought iron, the lower grades of smelted or "pig" iron are employed. The mechanical process of "puddling" is melting and stirring the pig iron,

until the proper degree of oxidation is secured, and then working of the molten metal into a pasty mass or "puddle-ball," which may then be squeezed or hammered into a suitable shape or "bloom" for rolling into bars, technically known as "muck-" or "puddle-bars." When cold, this intermediate product is sheared and bundled into piles of proper sectional area, to which wrought scrap is most commonly added, after which the pile so formed is brought to a welding heat in a "heating-furnace," to be afterward passed through the finishing rolls, becoming "merchant iron," a finished product.

The strength and quality of the finished product depends, naturally, upon the character of the crude iron or "stock," the skill in puddling, or reducing the non-metallic substances, and particularly upon the method and materials used in forming the "pile" to be made into "blooms." All metallic iron contains more or less impurities, and in general such elements as silicon, manganese, carbon, sulphur, and phosphorus appear; the best wrought iron can only be produced from crude iron containing a limited percentage of sulphur and phosphorus, neither of which can be entirely eliminated in the puddling process, a sufficient percentage being left in the product to give unfavorable results if they were able to exert their full effect in the production of crystallization of the fibres of the metallic iron; but the slag, resulting from the other non-metallic impurities, overcomes this tendency in a degree.

The presence of considerable percentages of sulphur produces in the finished iron a condition termed by smiths as "red short"—an inclination to disintegrate or crumble whenever the iron is heated to a working temperature; the cohesion of its particles being affected adversely, the strength of the metal is correspondingly reduced.

The effect of phosphorus, the most detrimental of all the

alloys, is exactly opposite to that produced by excess quantities of sulphur, in that it makes the finished product "cold short," crystalline in appearance, of uncertain strength, and liable to fracture from sudden shock.

That the character or arrangement of the piles has a direct relation to the strength of the product is explained by Campbell as follows: "If the piles were square and were made up of similar pieces of equal length, each layer being at right angles to the one below, and if the bloom were rolled equally in each direction, it is evident that the plate would be as strong in the line of its length as of its breadth; but as the bars from which the pile is formed have been made by stretching the material in one way, and as all practical work requires a piece of greater length than width, it will be seen that the finished product will show much better results when tested in the direction of its length than its width. The result will also depend upon the skill with which the pile has been constructed; upon the perfection of the welding as influenced by the heating and the rapidity of handling, and upon the freedom of the iron from thick layers of slag."

To secure a pure, refined iron, such as should be specified for structural work, it is necessary, first, to require that the chemical components of the crude iron shall be such as under favorable treatment shall give the desired chemical product; secondly, the production of the muck-bar in suitable condition being largely dependent upon the skill of the workmen, other things being equal, preference should be given the product of old and reputable establishments, and this applies with equal force to the finished product, for it is customary in the manufacture of finished iron to utilize large quantities of miscellaneous "scrap iron," purchased in the open market, and this scrap, without any careful or intelligent assortment, is piled with the sheared muck-bar until the proper size and weight bloom are obtained, when it is heated to a welding

heat and rolled into the required shape. The effect of scrap steel or of impure metal within the mass of this pile is to destroy the homogeneity and produce segregation.

Whilst it is true that sometimes carelessness is responsible for such process of manufacture, more frequently it is the direct result of determined effort upon the part of the manufacturer to cheapen his product by utilizing cheap, miscellaneous scrap metal. When nicked and broken across, or when ruptured under tension, the appearance of this iron, instead of the long, fibrous arrangement of the molecules, indicative of tough, strong material, is crystalline, and the fracture shows a decided brittleness.

According to Prof. J. B. Johnson, there are three well-recognized causes of this crystalline structure, indicative of inferior material.

“First, the so-called wrought iron may have been rolled from fagotted scrap, some of which was probably high-carbon steel, and this portion would show a crystalline fracture.

“Second, the puddle-ball may have been formed under too great a heat (a common fault), so that a portion of it had been actually melted, thus forming of this portion ingot metal or steel, which part would, when cold, be wholly crystalline.

“Third, the puddling process may have been incomplete, when, with a low fire, some of the unreduced pig iron would be removed from the ball, and this would form a coarsely crystalline portion of the final rolled bar.”

Steel manufactured for constructive purposes is at present produced by one of two processes: either the “Bessemer” or converter, or by the “open-hearth” or furnace method. From the character of the lining of the converter or furnace being either acid or basic, a further distinctive technical term of “acid” or “basic Bessemer,” or “acid” or “basic open-hearth steel” is commercially used.

Physical Differences between Iron and Steel.—The metamorphose of cast iron into steel is produced, as is the case with the refinement of iron, by oxidation as the principal factor. Made from the same material, and transformed by similar chemical agencies, it is not surprising that there is a great similarity of the two finished products, one termed wrought iron and the other structural steel. The difficulty of defining steel and the narrow line separating it from iron is clearly put in the "Manufacture and Properties of Structural Steel" as follows:

"Prior to the development of the Bessemer and open-hearth processes there was little room for disagreement as to the dividing line between iron and steel. If it would harden in water it was steel; if not, it was wrought iron. When the modern methods were introduced, a new metal came into the world. In its composition and in its physical qualities it was exactly like many steels of commerce, and naturally and rightly it was called steel. By degrees these processes widened their field, and began to make a soft metal which possessed many of the characteristics of ordinary wrought iron, and which was not made by any radical changes in methods, but simply by the use of a rich ferro-manganese. Notwithstanding this fact, some engineers claimed that the new metal was not steel, but iron. The makers replied that it was made by the same process as hard steel, and that it was impossible to draw a line in the series of possible and actual grades of product which they made." Mr. Howe, in his "Metallurgy of Steel," says, "The terms Iron and Steel are employed so ambiguously and inconsistently that it is to-day impossible to arrange all varieties under a simple and consistent classification." Continuing to quote from the "Manufacture and Properties of Structural Steel," "It is true, as argued by Mr. Howe, that many of the common products of metallurgy and art shade imperceptibly into one another; but it is surely extraordinary when the

dividing line can not be drawn even in theory, much less in practice; when, wherever it falls, it must divide, not intermediate, but finished products, used in enormous quantities, and blending into one another by insensible gradations, and when every shade of these variations is the subject of rigorous engineering specifications."

It is customary and necessary, in ordering steel, to give a certain margin in filling specifications, and it will be evident, no matter how close this margin is, that if a line could be drawn, it would not infrequently happen that he who ordered ingot iron would receive steel, and he who ordered steel would receive ingot iron.

Many different tests have been proposed at various times for determining the mechanical properties of steels, but although some of them are of value in special cases, the one method of investigation which has become well nigh universal is to break by a tensile stress and measure the ultimate strength, the elastic limit, the elongation, and the reduction of area. Strictly speaking, none of these properties has any direct connection with hardness, and it is also true that in special instances, as with very high carbons, hardening may reduce the tensile strength by the creation of abnormal internal strains; but in all ordinary steels it is certain that hardening is accompanied by an increase of strength, by an exaltation of the elastic limit, and a degree in ductility.

"The fact that common soft steel is materially strengthened by chilling has been widely recognized for many years, but the extent of the alteration in physical properties in the softest and purest metals is not generally understood."

The table on page 17 shows the results of a series of tests made by Mr. H. H. Campbell.

Again from "Manufacture and Properties of Structural Steel":

"The classification by hardening is a dead issue in our

country. It had quietly passed away unnoticed and unknown before the committee of the Mining Engineers had met, and the best efforts of that brilliant galaxy of talent could only produce a kindly eulogy."

EFFECT OF QUENCHING ON THE PHYSICAL PROPERTIES
OF DIFFERENT SOFT STEELS.

NOTE.—Bars were 2 in. × $\frac{3}{8}$ in. flats, rolled from 6 in. × 6 in. ingot, and were chilled at a dull yellow heat.

Number of Test-bar		1	2	8	4	5	6
Composition, per cent.	Carbon.	.09	.12	.11	.12	.09	.10
	Manganese.	.44	.32	.43	.32	.39	.16
	Phosphorus.	.011	.004	.010	.004	.017	.010
	Sulphur.	.033	.027	.010	.027	.031	.019
Ultimate strength, pounds per square inch	Natural.	49390	48960	48960	48260	49760	46250
	Quenched.	66080	65670	66300	63640	62280	58380
Elastic limit, pounds per square inch.	Natural.	33270	33390	33010	32340	31040	29830
	Quenched.	47310			50170	46580	40500
Elastic ratio, per cent.	Natural.	67.26	68.20	67.42	67.01	62.38	64.50
	Quenched.	71.60			78.83	74.79	69.38
Elongation in 8 in., in per cent.	Natural.	29.75	31.00	32.50	32.50	31.25	37.75
	Quenched.	18.75	16.25	15.00	17.75	23.75	27.50
Reduction of area, per cent.	Natural.	50.80	52.50	54.10	55.75	49.00	68.38
	Quenched.	56.50	63.27	63.47	64.47	65.15	68.97

"Strictly speaking, some mention must be made of hardening in a complete and perfect definition, for it is possible to make steel in a puddling-furnace by taking out the viscous mass before it has been completely decarburized; but this crude and unusual method is now a relic of the past, and may be entirely neglected in practical discussion.

"No attempt will be made here to give any iron-clad formula, but the following statements portray the current usage in our country:

"(1) By the term 'wrought iron' is meant the product of the puddling-furnace or the sinking-fire.

"(2) By the term 'steel' is meant the product of the cementation process, or the malleable compounds of iron made in the crucible, the converter, or the open-hearth furnace."

Effect of Heating.—The changes produced in the physical properties of steel through reheating and chilling by quenching are radical; little less so is the effect produced by annealing, or the tempering of steel by reheating as in shop-work, where the metal, after being heated for rolling or bending, is allowed to cool gradually.

The average extent of the changes thus produced is shown from the tests made by Mr. H. H. Campbell upon specimens both of Bessemer and open-hearth steels, and recorded as follows:

“The decrease in ultimate strength by annealing the Bessemer bars averaged 4175 pounds per square inch in the rounds and 5683 pounds in the flats, while the open-hearth was lowered 5134 pounds in the rounds and 7649 in the flats.

“In this important and fundamental quality the two kinds of steel are very similarly affected, but in other particulars there seems to be a radical difference which is difficult to explain. The elongation of the Bessemer steel is increased by annealing in every case except two, the average being 1.33 per cent., while the open-hearth metal shows a loss in three cases, with an average loss for all cases of 0.21 per cent. This is not very conclusive, but there is a more marked difference in the reduction of area, for in the Bessemer steel there is an increase in the annealed bar in every case varying from 7 to 15.18 per cent., while the open-hearth showed an increase in only three cases, the maximum being 2.81 per cent., and a decrease in five cases, the greatest loss being 7.20 per cent.”

The results arrived at by Mr. Campbell after exhaustive tests, comparing the effect upon both Bessemer and open-hearth steels, are as follows: “Annealing is useful in removing the strains caused by distortion, for in such cases the gain in safety more than counterbalances the loss of strength, but it may be accepted as a general rule that steel is in its best condition when it leaves the rolling-mill; that the shop treatment

should retain, as far as possible, the natural qualities of the metal; and that the bar should be heated only when it is necessary to make a permanent bend."

Constructive or soft steel is produced, as has been stated, by one of two processes, the Bessemer and the open-hearth, and a technical classification of the product is determined by the character of the lining employed in the furnace, whether acid or basic. An authentic, brief, and comprehensive statement descriptive of the two general methods of manufacturing structural steels is copied in full from the work so frequently herein quoted, and is as follows:

Bessemer Steel.—"The acid-Bessemer process consists in blowing air into liquid pig iron for the purpose of burning most of the silicon, manganese, and carbon of the metal, the operation being conducted in an acid-lined vessel, and in such a manner that the product is entirely fluid. The way in which the air is introduced is a matter of little importance as far as the character of the product is concerned. . . . The lining is made of either stone or brick, or other refractory material, and is about one foot thick. . . . The blast is kept at a pressure of from 25 to 30 pounds per square inch during the first part of the blow, but, in the case of a very hot charge, or if the slag is sloppy, the pressure must sometimes be reduced to 10 pounds after the flame 'breaks through' (*i.e.*, after the carbon begins to burn), 'to prevent the expulsion of the metal from the nose . . . the heats, whether light or heavy, are usually blown in from 7 to 12 minutes.'"

After the chemical change has taken place whereby the cast iron has become molten steel, the fluid metal is tapped or drawn off into cast-iron moulds, where the metal solidifies so that it may be handled, when it is then called an ingot, and, as such, reheated in a furnace, passed through trains of rolls, as is the case with wrought iron, and rolled into the desired shape.

The basic Bessemer process is identical with that just described, except the converter or furnace is lined with a material that resists the action of the basic slags. Again quoting from the "Manufacture and Properties of Structural Steel": "This lining is usually made of dolomite, but sometimes a limestone is used containing a very small proportion of magnesia. The stone must be burned thoroughly to expel the last trace of volatile matter, and then ground and mixed with anhydrous tar. The highest function of the lining is to remain unaffected, and allow the basic additions to do their work alone, so that the rapid destruction of a basic, as compared with an acid lining, is not due to any necessary part it plays in the operation, but to the fact that there is no basic material in nature which is plastic, and which by moderate heating will give the firm bond that makes clay so valuable in acid practice."

Acid and basic Bessemer steel is sometimes known as converter steel, and depending largely upon the product of the blast-furnace, as well as the possibility of large output, the cost of production of Bessemer steels is considerably less than the product of the open-hearth process, which finds it advantageous to use a considerable proportion of scrap steel, and is more limited in the matter of its output. It is claimed by many authorities that the metallurgical conditions are such that a greater degree of certainty in the production of open-hearth is possible, and, whether this be true or not, the fact remains that the general tendency among engineers and as evidenced by numerous recent specifications, is to give a preference to the open-hearth product over Bessemer steels.

A description of the process of manufacture of the open-hearth product is as follows, and is also from Mr. Campbell's admirable work:

Open-hearth Steel.—"The open-hearth process consists of melting pig iron, mixed with more or less wrought iron, steel, or similar iron products, by exposure to the direct action of

the flame in a regenerative furnace, and converting the resultant bath into steel, the operation being so conducted that the final product is entirely fluid."

As stated, this regenerative furnace steel is classified as acid or basic, depending upon the formation or texture of the lining.

"In one the hearth is lined with sand, and the slag is silicious; in the other the hearth is made of such material that a basic slag can be carried during the operation."

As is the case with wrought iron, the metalloids as carbon, silicon, sulphur, manganese and phosphorus affect the finished product, carbon being the least uncertain and detrimental of the alloys, for structural steel being a carbon steel, its presence should possibly not be limited. Also as with iron, the most important of the metalloids are sulphur and phosphorus, the last being the most to be feared. Regarding the effect of sulphur on steel products, Mr. Campbell says: "Nothing is better established than the fact that sulphur injures the rolling qualities of steel, causing it to crack and tear, and lessening its capacity to weld. . . . In the making of common steel for simple shapes, a content of .10 per cent. is possible, and may even be exceeded if great care be taken in the heating, but for rails and other shapes having thin flanges it is advantageous to have less than .08 per cent., while every decrease below this point is seen in a reduced number of defective bars."

Effects of Phosphorus.—The effects of phosphorus, the most potent of all the metalloids for evil, is thus given by Mr. Campbell: "Of all the elements commonly found in steel, phosphorus stands pre-eminent as the most undesirable. It is objectionable in the rolling-mill, for it tends to produce coarse crystallization, and hence lowers the temperature to which it is safe to heat the steel, and, for this reason, phosphoric metal should be finished at a lower temperature than pure steel in order to prevent the formation of a crystalline

structure during cooling. Aside from these considerations its influence is not felt in a marked degree in the rolling-mill, for it has no disastrous effect upon the toughness of red-hot metal when the content does not exceed .15 per cent."

A discussion of the effects of phosphorus in steel by Howe's "Metallurgy of Steel," and summarized by Mr. Campbell, is as follows:

"(1) The effect of phosphorus on the elastic ratio, as on elongation and contraction, is very capricious.

"(2) Phosphoric steels are liable to break under very slight tensile stress if suddenly or vibratorily applied.

"(3) Phosphorus diminishes the ductility of steel under a gradually applied load as measured by its elongation, contraction, and elastic ratio when ruptured in an ordinary testing-machine, but it diminishes its toughness under shock to a still greater degree, and this it is that unfits phosphoric steels for most purposes.

"(4) The effect of phosphorus on static ductility appears to be very capricious, for we find many cases of highly phosphoric steel which show excellent elongation, contraction, and even fair elastic ratio, while side by side with them are others produced under apparently identical conditions but statically brittle.

"(5) If any relation between composition and physical properties is established by experience, it is that of phosphorus in making steel brittle under shock; and it appears reasonably certain, though exact data sufficing to demonstrate it are not at hand, that phosphoric steels are liable to be very brittle under shock, even though they may be tolerably ductile statically. The effects of phosphorus on shock-resisting power, though probably more constant than its effects on static ductility, are still decidedly capricious. . . ."

Mr. Campbell's conclusion in regard to the effects of phosphorus in the composition of steel, and the limit to be

placed upon its presence, is as follows: "No line can be drawn that shall be called the limit of safety, since no practical test has ever been devised which completely represents the effect of incessant tremor. For common structural materials the critical content has been placed at .10 per cent. by general consent, but this is altogether too high for railroad-bridge work. All that can be said is that safety increases as phosphorus decreases, and the engineer may calculate just how much he is willing to pay for greater protection from accident."

To what extent specifications calling for reduction of this element affect the market price of materials is shown from the following, taken from Prof. Pence's "Stand-pipe Accidents and Failures":

"A recent proposal for the construction of an important stand-pipe in a Western city included bids according to five limitations for phosphorus, running from 0.08 to 0.04 per cent. inclusive. The relative bids on the superstructure for the several grades of steel, taking that for the highest phosphorus limit as unity, were as follows:

Phosphorus Limit.	Relative Bid.
0.08.....	1.00
0.07.....	1.03
0.06.....	1.08
0.05.....	1.17
0.04.....	1.23

"The plates were to be 'soft, acid, open-hearth steel,' of 54,000 to 62,000 lbs. per sq. in. in tensile strength; elastic limit, 31,000 lbs. per sq. in.; minimum elongation in 8 inches, 26%; minimum reduction of area, 50%; cold bent flat; and not more than 0.08% phosphorus, and less per cent. as per detailed bid."

Standard specifications for structural steel have been adopted in the United States as follows:

MANUFACTURERS' STANDARD SPECIFICATIONS.

STRUCTURAL STEEL.

1. *Process of Manufacture.*—Steel may be made by either the open-hearth or Bessemer process.

2. *Testing.*—All tests and inspections shall be made at place of manufacture prior to shipments.

3. *Test-pieces.*—The tensile strength, limit of elasticity, and ductility, shall be determined from a standard test-piece cut from the finished material. The standard shape of the test-piece for sheared plates shall be as shown by the following sketch :

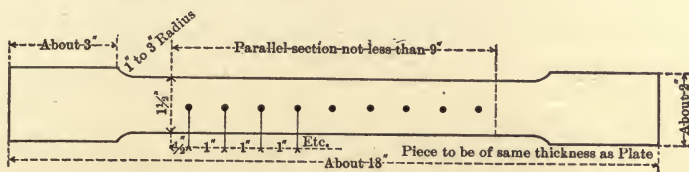

On tests cut from other material the test-piece may be either the same as for plates, or it may be planed or turned parallel throughout its entire length.

The elongation shall be measured on an original length of 8 ins., except when the thickness of the finished material is $\frac{5}{16}$ in. or less, in which case the elongation shall be measured in a length equal to sixteen times the thickness; and, except in rounds of $\frac{3}{8}$ in. or less in diameter, in which case the elongation shall be measured in a length equal to eight times the diameter of section tested. Two test-piece shall be taken from each melt or blow of finished material, one for tension and one for bending.

4. *Annealed Test-pieces.*—Material which is to be used without annealing or further treatment is to be tested in the condition in which it comes from the rolls. When material is to be annealed or otherwise treated before use, the specimen representing such material is to be similarly treated before testing.

5. *Marking.*—Every finished piece of steel shall be stamped with the blow- or melt-number, and steel for pins shall have the blow- or melt-number stamped upon the ends. Rivet and lacing steel, and small pieces for pin-plates and stiffeners, may be shipped in bundles securely wired together, with the blow- or melt-number on a metal tag attached.

6. *Finish.*—Finished bars must be free from injurious seams, flaws, or cracks, and have a workmanlike finish.

7. *Chemical Properties*.—Steel for railway bridges: Maximum phosphorus, .08 per cent. Steel for buildings, train-sheds, highway bridges, and similar structures: Maximum phosphorus, .10 per cent.

8. *Physical Properties*.—Steel shall be of three grades, *rivet*, *soft*, and *medium*.

9. *Rivet Steel*.—Ultimate strength, 48,000 to 58,000 pounds per square inch.

Elastic limit, not less than one-half the ultimate strength.

Elongation, 26 per cent.

Bending test, 180 degrees flat on itself, without fracture on outside of bent portion.

10. *Soft Steel*.—Ultimate strength, 52,000 to 62,000 pounds per square inch.

Elastic limit, not less than one-half the ultimate strength.

Elongation, 25 per cent.

Bending test, 180 degrees flat on itself, without fracture on outside of bent portion.

11. *Medium Steel*.—Ultimate strength, 60,000 to 70,000 pounds per square inch.

Elastic limit, not less than one-half the ultimate strength.

Elongation, 22 per cent.

Bending test, 180 degrees to a diameter equal to thickness of piece tested, without fracture on outside of bent portion.

12. *Pin Steel*.—Pins made from either of the above-mentioned grades of steel shall, on specimen test-pieces cut at a depth of one inch from surface of finished material, fill the physical requirements of the grade of steel from which they are rolled, for ultimate strength, elastic limit, and bending, but the required elongation shall be decreased 5 per cent.

13. *Eye-bar Steel*.—Eye-bar material, $1\frac{1}{2}$ inches and less in thickness, made of either of the above-mentioned grades of steel, shall, on test-pieces cut from finished material, fill the requirements of the grades of steel from which it is rolled. For thickness greater than $1\frac{1}{2}$ inches, there will be allowed a reduction in the percentage of elongation of 1 per cent. for each $\frac{1}{2}$ of an inch increase of thickness, to a minimum of 20 per cent. for medium steel and 22 per cent. for soft steel.

14. *Full-size Test of Steel Eye-bars*.—Full-size test of steel eye-bars shall be required to show not less than 10 per cent. elongation in the body of the bar, and tensile strength not more than 5000 pounds below the minimum tensile strength required in specimen tests of the grade of steel from which they are rolled. The bars will be required to break in the body, but should a bar break in the head, but develop 10 per cent. elongation and the ultimate strength specified, it shall not be cause for

rejection, provided not more than one-third of the total number of bars tested break in the head ; otherwise the entire lot will be rejected.

15. *Variation in Weight.*—The variation in cross-section or weight of more than $2\frac{1}{2}$ per cent. from that specified will be sufficient cause for rejection, except in the case of sheared plates, which will be covered by the following permissible variations :

(a) Plates $12\frac{1}{2}$ pounds or heavier, when ordered to weight, shall not average more variation than $2\frac{1}{2}$ per cent. either above or below the theoretical weight.

(b) Plates from 10 to $12\frac{1}{2}$ pounds, when ordered to weight, shall not average a greater variation than the following :

Up to 75 inches wide, $2\frac{1}{2}$ per cent., either above or below the theoretical weight.

Seventy-five inches and over, 5 per cent., either above or below the theoretical weight.

(c) For all plates ordered to gauge there will be permitted an average excess of weight over than corresponding to the dimensions in the order equal in amount to that specified in the following table.

TABLE OF ALLOWANCES FOR OVERWEIGHT FOR RECTANGULAR PLATES WHEN ORDERED TO GAUGE.

Thickness of Plate.	Width of Plate.			Thickness of Plate.	Width of Plate.	
	Up to 75 in.	75 in. to 100 in.	Over 100 in.		Up to 50 in.	50 in. and above.
$\frac{1}{4}$ inch.	10 per cent.	14 per cent.	18 per cent.	$\frac{1}{8}$ up to $\frac{5}{32}$	10 per cent.	15 per cent.
$\frac{5}{16}$ "	8 " "	12 " "	16 " "	$\frac{5}{32}$ " " $\frac{3}{16}$	$8\frac{1}{2}$ " "	$12\frac{1}{2}$ " "
$\frac{3}{8}$ "	7 " "	10 " "	13 " "	$\frac{3}{16}$ " " $\frac{1}{4}$	7 " "	10 " "
$\frac{7}{16}$ "	6 " "	8 " "	10 " "			
$\frac{1}{2}$ "	5 " "	7 " "	9 " "			
$\frac{9}{16}$ "	$4\frac{1}{2}$ " "	$6\frac{1}{2}$ " "	$8\frac{1}{2}$ " "			
$\frac{5}{8}$ "	4 " "	6 " "	8 " "			
Over $\frac{5}{8}$ "	$3\frac{1}{2}$ " "	5 " "	$6\frac{1}{2}$ " "			

Work of International Association.—An effort is being made at this time by the International Association for Testing Materials, to establish international standard specifications for the inspection of iron and steel. Each national branch will contribute to the grand council a committee report, dealing in part with "Determination of Methods of Testing the Homogeneity of Iron and Steel, looking to their Eventual Use for Inspection," and from these reports a new

set of standard specifications may be evolved, but whether in general practice they are to supersede those employed at this time is, of course, entirely conjectural.

Some little time since the American Division of the International Committee submitted a tentative report, subject to further consideration and discussion before final action is taken at a meeting called for October. So universally has this report been endorsed and so favorably received, that the possibility seems that it will not be materially modified, and that it will receive the approval of the International Committee and spring into general use throughout the civilized world. It is interesting to note that, in treating of structural material, its introductory, defining the process of manufacture, advocates a radical departure from the "Manufacturers' Standard Specifications" in that it eliminates the Bessemer process of manufacture, requiring that "Steel shall be made by the open-hearth process." This is not such a radical departure as it would seem upon the surface, as prior to this report, the tendency toward a preference for this product was everywhere in evidence, and had become a commercial possibility through the erection of numerous open-hearth plants of large capacities, an immense impetus having been given this method of production by the successful commercial development of the open-hearth continuous process, permitting the use of fluid metal from blast-furnaces, mixers, and cupolas. Altogether, the "signs of the times" distinctly point to the increased production of open-hearth steel for structural materials, possibly to the complete elimination of the Bessemer method of manufacture.

For some time past efforts have been made by various technical associations to bring about a harmonious agreement looking toward the formulation and adoption of standard specifications for iron and steel, and although a general acceptance and agreement has not yet been concluded, along with the present tendency

toward standardization, tentative acceptance of some important changes in the present Manufacturers' Standard has been presented and is meeting with favor from those interested.

The most important of the changes made relates to the adoption of a single standard grade of structural steel for all purposes of 60,000 lbs. tensile strength, with an allowable variation of 5000 lbs. either way, and the omission of any requirement as to reduction of area and elastic limit. It is also strongly urged that more importance should be given to cold-bend test, either plain or nickelled, of full-sized sections. The outcome of this movement will be watched with interest.

CHAPTER III.

THE USE OF IRON.

NOTWITHSTANDING the inability of metallurgists to determine with certainty the precise point in its evolution when iron is converted into steel, and conceding scientific uncertainty as to technical definition, the well-known characteristics of iron and steel exhibit radical differences, and practical metal-workers seldom err in determining each with certainty; therefore comparison is entirely pertinent in considering both metals as materials for stand-pipe construction, and the individual merits of each, referring to general utility, fitness, and comparative cost, should receive consideration.

Until 1880 iron plate was used almost exclusively in the construction of metallic reservoirs, although a steel pipe is recorded as having been erected as early as 1876, about which time the commencement of the steel industry in the United States may be said to have dated. From that time the introduction of metallic members in structures slowly and timidly advanced, criticised at each step; but, profiting by each failure, overcame the difficulty until at the present time few mills continue the practice of rolling iron shapes and plates for structural work, and specifications calling for ferric members are now practically obsolete.

The United States Statistical Bureau of the Treasury Department, for the year 1899, places the United States at the head of the steel and iron producing countries of the world, with a record of 13,620,703 tons of pig iron produced, of which 78.1 per cent., or 10,639,857 tons, was converted into steel.

The Change to Steel.—The underlying cause for a change so radical as to amount to an industrial revolution, is the appreciation and realization of the commercial and constructive value of steel, leading to scientific advance constantly improving the physical and chemical properties, whilst the increased demand introduced new facilities for reducing the price of the product below that of commercial wrought iron. As has been stated, at this time, of the 992 metallic reservoirs in the United States, 220 are of iron and 292 of steel, leaving 480 undefined. Whilst these records give only a small excess of steel as compared with iron structures, the increased use of steel is more apparent when it is considered that only within the past few years has steel been recognized as a suitable metal for such work.

Classification of Failures.—From the best procurable records amongst the entire number of metallic reservoirs of water-supply plants in this country, there are recorded 54 partial and complete failures and collapses, 17 of which are credited to steel structures, whilst only 7 known to have been built of iron plates have failed. From this it would seem that steel tanks are more liable to collapse than iron ones, but this fact should only be admitted conditionally and after consideration of the causes inducing the failures.

Of the 17 complete and partial failures attributed to the list of steel tanks, the date of erection and failure shows the majority of them to have been constructed during what might be termed the experimental stage of steel-production, as, for instance, chemical analysis of the steel used in four of these tanks shows a large proportion of phosphorus—in one case as high as 0.162%, which would certainly have caused the plate to be rejected at this time, unless its use were dictated by distinctly dishonest conditions.

Again, a consideration of the circumstances and a study of the prevailing conditions and designs, show three of the re-

ported pipes to have been of most unusual and eccentric design, whilst two pipes collapsed owing to failure of designers to provide plates whose unit stress should be suitable for conditions well recognized at this date. Deducting those pipes whose partial or total destruction should have been provided against, there remains only four failures unexplained, and one of these might be placed if the history of the structure were known.

In view of this testimony and the most conclusive and practical evidence offered by the constant and increasing use of structural steel, there can be no question as to the fitness and adaptability of this product to the many purposes of the mechanical arts.

Continuing the consideration of this question, an interesting discussion upon the choice of materials may be found in Prof. W. D. Pence's "Stand-pipe Accidents and Failures," which, on account of its clearness and propriety, is presented here literally:

“**Relative Merits.**—In weighing the relative merits of steel and wrought iron as materials for the construction of stand-pipes, it may not be denied that each material has points of excellence possessed either in a less degree, or perhaps not at all, by the other. Judging alone from the recorded failures of the two metals in actual service, wrought iron appears preferable to steel. However, an entirely just interpretation of this record must recognize the fact that a majority of the total failures of steel stand-pipes may be traced to the use of ill-adapted or exceptionally inferior grades of that metal. With this qualification, the contrast in the records of the two materials is much reduced, if indeed it is not quite eliminated. Careful consideration of the foregoing records and facts related thereto leads to the following conclusions:

“(1) That steel plate of cheap grades is certainly a dangerous material to use in the construction of stand-pipes.



“(2) That steel plate of proper quality is a safe material for the construction of stand-pipes.

“(3) That wrought-iron plate, equivalent in quality to the usual grades of that material hitherto employed for stand-pipe construction, is a safe material for this purpose.

“The first of these conclusions is substantiated by a number of the more widely known failures of steel stand-pipes. The second is warranted by the scarcity of failures of steel stand-pipes, in whose construction proper grades of plate metal were used. The truth of the third is evidenced by the several classifications of accidents and failures.

“The decided preference for steel, which has grown so rapidly in other fields of work, applies with full force in the construction of stand-pipes, and it has now reached such a stage that exceedingly few concerns make a specialty of building wrought-iron stand-pipes. An important result of this evolution, which in the future may require a qualification of the third conclusion above stated, is thus described by a recognized authority in the field of structural tests: ‘Steel for most structural purposes has so far replaced wrought iron that it is now difficult to get competition among the manufacturers of wrought iron for structural purposes. Many of the manufacturers who are still making wrought iron find that the demand is so much greater for steel—and in fact the profit better in steel—that they are not putting the care and attention to the manufacture of wrought iron that they have in the past, and it is getting every month harder and harder to obtain the best grades of wrought iron for structural purposes. There are, however, still a few concerns who are holding up their reputations and manufacturing as good wrought iron as in the past.’”

Another authority in the same field expresses the opinion that: “The quality of wrought iron is about the same as it was before the ‘era of steel,’ but engineers and inspectors

who have to deal with materials for structural purposes are no longer as familiar with iron as they were some time ago, or as they are with steel."

In view of the conflict of opinion indicated by the expressions above quoted, particular interest attaches to the following statement from a well-known firm of boiler-merchants, having an experience covering a period of more than half a century:

"There are very few mills to-day that have among their employees men who can make first-class iron, and by reason of the fact that orders for iron are so exceedingly rare and these men can be put at the work only at infrequent intervals, their skill has departed and they have no longer the ability to make as good iron as was made five or ten years ago.

"Whatever the present status of the question, it is pertinent to observe that the results of a very similar rivalry between steel and wrought iron in the manufacture of T rails, some years ago, tends forcibly to confirm the belief that the quality of the superseded metal must decline sooner or later in the case under consideration. Such deterioration having taken place, it seems quite certain that wrought iron could show no superiority over steel in open competition, and, as remarked in discussing this subject at the conclusion of the original record of accidents, it seems altogether probable that the favorable showing of wrought iron indicated by the record of stand-pipe failures would soon be forfeited were the extensive use of wrought iron for this purpose to be suddenly resumed without a corresponding restoration of the former qualities of that metal. Fortunately, the few firms that have adhered loyally to the use of wrought-iron and have built most of the large wrought-iron stand-pipes during the period of alleged retrogression, seem to have recognized the impor-

tance of using good grades of that metal, so that the decline in safety, above suggested, has probably not begun.

“Very naturally the reduced cost of steel, attended by a growing confidence in its uniformity and high quality when demanded, has led to a decided preference for that metal. That this preference will not be modified under present conditions seems very certain, but this fact will not, and very properly should not, prevent the use of wrought iron of appropriate grades when preferred. Since little assurance of excellence is to be found in the mere names steel or wrought iron, the really vital consideration is not so much which metal as what grade of the chosen metal.”

Upon a subject where there is room for so wide an expression of individual opinion, and in view of the conservative tendency which bids the manufacturer as well as the engineer “Be not the first by whom the new is tried,” there is little wonder at the following expression from one of the most long-established and eminently reliable and respectable metal workers upon the use of steel or iron plate in stand-pipe construction:

“We do consider iron plates more uniform in composition and better adapted for stand-pipe construction, regardless of question of cost, than steel plates of the standard chemical and physical properties, as we are able to obtain those plates. The difficulty the mills rolling plates meet with is that they can not produce all plates of the quality they desire.

“Our specifications for a stand-pipe iron plate are merely that the plate shall be double refined and fibrous in nature, not crystallized in its composition, 48,000 to 50,000 pounds tensile strength, and made from such mixture of pig iron as we know will unite in making a strong plate. We have used one mixture of pig iron, comprising three different grades of pig, for a period of twenty years in stand-pipe plates, and there never has been a failure of one plate of this material. It

may be an interesting fact for you to know that every stand-pipe which has mysteriously broken or burst, has been built of steel plates. (Statement not substantiated by facts.)

“ We have no specifications of our own for steel plates, but have adopted in our use either the specifications adopted as standard by the American Rolling Mill Association, or the specifications adopted by the American Boiler Makers’ Association, either of which we regard as good as can be obtained. . . . We would hesitate very much before using steel rivets in stand-pipe work. While the steel makers have made great progress and improved very much in the manufacture of steel plate, they have not met with equal success in manufacturing a rivet steel.

“ The difference between the United States Naval Department and the Carnegie Company in reference to ship-plates made for the department, and to be used at Newport News, is a fair illustration of the inability of plate makers to make a uniform, homogeneous grade of steel plate in every case. If you read up in the matter, you will recall that the plates were made under strict specifications as to the physical and chemical requirements, and that every stage in the process of their manufacture was watched by experts, both on the part of the Government and on the part of the manufacturer, and yet when the plates were finished and shipped to Newport News, the ship-builders and the experts watching the construction of the work, discovered that many plates cracked. The matter was referred to a commission and it was agreed that in view of all the facts, and allowing for the inability to control the product of a steel mill, the Government could not condemn all the plates delivered, neither could they accept all, but that the use of plates would depend entirely upon the result of the shop-work at Newport News.”

The foregoing having to do principally with the relative utility of the two metals and regardless of commercial con-

siderations, and as these last are governing factors in this practical age, a comparison is certainly not complete without considering market values or intrinsic worth of the two metals.

One of a set of specifications calling for proposals for wrought-iron stand-pipe construction was issued in October, 1897, the dimensions of the pipe being 15 ft. by 110 ft., the metal to conform to the following requirements:

“ The material of which the stand-pipe shall be built shall be a good, sound, rolled plate, having a tensile strength of not less than forty-eight (48,000) thousand pounds per square inch of section; elastic limit, twenty-four (24,000) thousand pounds; elongation not less than 15% in a full section of test-piece 8 in. long, and on examination show no sign of inferior workmanship. Each plate shall be stamped with the name of the manufacturer and its tensile strength.” The shop to whom the award was made furnished at the same time an alternate proposal for steel plate under the following manufacturers’ guarantee:

Steel plate	$\frac{3}{16}$ in. to $\frac{1}{4}$ in.	T. S. 60,000 to 66,000 lbs. per sq. in.
“ “	$\frac{1}{2}$ “ “ $\frac{5}{16}$ “	T. S. 54,000 “ 58,000 “ “ “ “
“ “	$\frac{5}{16}$ “ “ $\frac{3}{8}$ “	T. S. 56,000 “ 60,000 “ “ “ “
“ “	$\frac{7}{16}$ “ and upward	58,000 “ 64,000 “ “ “ “

Elastic limit more than $\frac{1}{2}$ T. S.

Elongation, 8 in. section (at least), 20% for all plates over $\frac{3}{8}$ in. thick.

Reduction of area, at least 50%.

The market prices of the two metals at the date of these proposals were as follows f. o. b. cars at mills:

Steel plate, \$1.05 per 100 lbs.

Iron plate \$1.40 “ “ “

Iron rivets 50 cts. per 100 more than steel.

The estimated weights of the stand-pipe material were as follows:

For iron, weight of plates and angles 81,600 lbs.

For steel, weight of plates and angles 85,680 lbs.

[NOTE.—Increased weight approximates an additional weight of 5% of steel over iron of like dimensions.]

Estimated amount of rivets, 4,600 lbs., including waste allowance.

The estimated cost of the superstructure, therefore, would be as follows:

81,600 lbs. iron plates at \$1.40.....	\$1142.40
85,680 lbs. steel plates " 1.05.....	899.64
	899.64
Difference in favor of steel.....	\$ 242.76

A comparison of the relative tensile strength of the two metals shows an advantage of about 22% in favor of steel, and had steel plate been selected, allowing for the increase of strength, the thickness might have been so reduced as to have permitted a reduction of 18,850 lbs., at the market price, effecting a further saving of \$197.92, or a total saving of \$440.68 had steel plate instead of wrought iron been used.

Comparative Cost.—In citing this particular 145,000-gal. stand-pipe for the purpose of arriving at conclusions as to relative cost of two possible metals, it may be urged that a higher grade of steel should have been insisted upon in order to make the comparison possible; however this may be, there can be no controversion of the fact that in equivalent metals the greater strength in proportion to volume and weight, gives steel a clear preference of something like 20% as applied to ruling prices. Such reasons have led to an almost universal demand for steel as a structural metal, and its choice may be conceded. This preference having been allowed, the particular grade of steel best adapted to constructive purposes must receive consideration.

It has been explained that structural steel is the product

of two processes, the Bessemer and open-hearth, either acid or basic.

At present there are no limitations fixed by the manufacturers' standard specifications in the matter of process of manufacture, one of the initial clauses of these specifications being "Steel may be made by either the open-hearth or Bessemer process," and no notice of the further refinement possibly resulting from the character of the furnace-lining is taken; notwithstanding this, each process of manufacture has its ardent advocates.

Comparative Homogeneity and Strength of Bessemer and Open-hearth Steels.—The Bessemer or converter process attaining its highest commercial development when operating upon a grand scale and in supplying an immense output, it is questionable whether such conditions are as favorable for scientific and exact production of steel as the less extensive furnace or open-hearth system, and where, at any period of evolution, tests may be made with regularity and certainty, and the process discontinued at the precise moment deemed most suitable.

In addition to the requirements of the manufacturers' standard specifications, the American Boiler Association demands "homogeneous" metal. If the initial metal is low in phosphorus and sulphur, the finished product may be sufficiently uniform for all practical purposes, but entire and absolute homogeneity and absence of segregation is at this time unattainable, but from the fact that in the acid open-hearth process the phosphoric and sulphuric components of the charge remain unaffected during the process of evolution, it is possible that this system of manufacture should be given a preference. This reasoning applies with equal force to the favor shown by some engineers toward the acid rather than the basic method of production, a definite allowance of some two or three per cent. sometimes being permitted, the idea being

that assurance shall be made doubly sure. It would seem that if this difference is to be recognized, the acid metal should alone be considered, except at a different commercial value, in the choice of structural steel. It is interesting to note, however, that the British Royal Navy has endorsed the following report: "With converter steel, riveted samples have given less average strength, greater variation in strength, and much more irregularity in modes of fracture than similar samples of open-hearth steel. The basic open-hearth metal has proven to be as good as that made on the acid hearth, and after full investigation, it will be used by the Admiralty in ship plates and boiler tubes on an equal footing."

In "Manufacture and Properties of Structural Steel," the author has this to say of the two processes of steel making: "My own experience leads me to think that Bessemer steel requires more work for the attainment of a proper structure than open-hearth metal, so that a thick bar is more apt to have a coarse crystalline fracture. This may be ascribed in any particular case to improper treatment, but if it is true that open-hearth metal would not be injured under a similar exposure, then it is proven that there is a difference between the metals, and if this be acknowledged, then there is no necessity for further argument.

"It is true that Bessemer metal has been used for rails, and that these are exposed to great stress and shock, but it is also true that a large number of rails break in service, and that the use of ordinary steel rail for bridges was long ago given up as dangerous. Moreover it is quite probable that the number of broken rails would be considerably reduced if they were made of open-hearth steel. It is acknowledged that the case is not yet closed, but until the foregoing statements are controverted by direct and positive evidence, the only safe way for the engineer is to prescribe that only open-hearth metal shall be used in all structures like railroad-bridges, where the steel is

under constant shock, and where life and death are in the balance. In this connection it should be stated that the method by which the steel is made cannot be discovered by ordinary chemical analysis. Certain experiments indicate that there is a difference between Bessemer and open-hearth steel in the character of the occluded gases, but this system of analysis is never resorted to in practice, and no provision is made for it in laboratories. Moreover it is doubtful if any expert would risk his reputation by asserting positively, from any such evidence, that a certain steel was made by either one or the other process. Consequently, when open-hearth metal is specified, a careful watch should be kept in the steel-works that there is no substitution of the inferior metal."

Many such honest but possibly biased arguments, controverting Mr. Campbell's opinions, might be inserted, but the tendency would be to lead us back to our starting-point, and it is possibly best to conclude with the following clear and unprejudiced, if not entirely scientific, statement of the case by a reputable trades journal:

Suitable Grades for Structural Work.—"The terms 'Bessemer' and 'open-hearth' steels have reference to methods or processes, and not necessarily to qualities. If a good quality of pig iron is made into steel by either the Bessemer or open-hearth process, it would be found that the latter was softer and more uniform under the stress of severe usage. But Bessemer steel made of good iron is better than open-hearth steel made of a cheap and inferior material. Therefore the Bessemer 'tank' steel of some manufacturers will run better than the open-hearth 'flange' steel of other makers. The name don't make the quality."

The preponderance of testimony and evidence seems to point to open-hearth metal as preferable for stand-pipe construction, but after having specified this, it is of the utmost importance to see, not only that it is furnished, but that the char-

acter of the finished product is of a suitable grade, whose chemical and physical properties having been specified, will be conscientiously made to meet the requirements. This advances two important subjects: first, What chemical and physical requirements are deemed most suitable for stand-pipe work? and, having determined this, How can certainty in obtaining what is considered requisite be secured?

The temperature at which steel is finished, depending obviously upon the mass being worked, has been shown to exert a marked effect upon its physical properties, and to such an extent that concessions are allowed amounting, as will be observed from the manufacturers' standard, to 10,000 pounds to cover the various widths and thicknesses of sections. There seems to be an increasing tendency to test each separate thickness, and in view of the fact that tests made from the same melt but upon different thicknesses of metal, finished at different temperatures show great variability in tensile strength, the practice seems commendable. Considering the physical characteristics of a good structural steel, authorities agree that the metal should be soft, tough, and ductile; disputing, however, as to the exact limits and variation in tensile strength. In this connection Mr. Campbell says:

“The tendency in the first epoch of steel structures was toward a hard alloy, but the later practice has been a continual progress toward toughness. There was a halt in this movement at a tensile strength of 60,000 pounds, not entirely on account of any magic virtue in the figure, but because the ordinary mild steels gave that result, and a much higher price was charged for a softer metal. The conditions to-day are somewhat different, for the reduced cost of low-phosphorus pig iron, and the introduction of the basic-hearth, have altered the economic situation.

“A steel with a tensile strength of 50,000 to 58,000 pounds per square inch is a most attractive material, possess-

ing all the good characteristics of wrought iron, with greater strength and toughness, and it seems probable that it will be extensively used in the future."

According to Campbell, the German specifications in most general use call for the following physical conditions:

"For rivets: Ultimate strength from 51,200 to 59,700 pounds per square inch; elongation, 22 per cent. in eight inches.

"For other structural material: Lengthwise tests, ultimate strength from 52,600 to 62,600 pounds per square inch; elongation, 20 per cent. in eight inches.

"Crosswise tests: Ultimate strength from 51,200 to 64,000 pounds per square inch; elongation, 17 per cent. in eight inches."

Commenting upon these requirements, Mr. Campbell says: "It is safe to say that if American engineers were satisfied with the German standards, there would not be one rejection for deficient ductility where there are twenty under our more rigid requirements; and if they would be content with a steel having an ultimate strength between 52,000 and 62,000 pounds per square inch, there would not be one-fifth the number of heats discarded for being outside of the tensile limits. The bearing of these facts upon the cost of the material is self-evident.

"I do not advocate any sacrifice of strength to economy, but I would impress upon the American engineers that this soft metal is eminently suited to structural work, while by maintaining their present chemical limitations and their requirements concerning ductility, they will be assured of a material which is equal in quality to any produced in the world."

In a recent publication, one of the largest manufacturers of structural steel records his conclusions as follows:

"The strength of structural steel depends largely on the

amount of the constituent elements that are associated with the iron, and each of which affect more or less the hardness and strength of the material.

“The principal of these are carbon, manganese, silicon, phosphorus, and sulphur, the first-named being purposely retained as useful or necessary, the others being rejected, as far as practicable, as objectionable when in excess of certain minute proportions.

“The grade and character of the steel is usually known by the percentage of contained carbon. Steel used in structures usually varies in tensile strength from 55,000 to 70,000 lbs. per square inch of section, or from .10 to .25 per cent. of carbon.

“The following table exhibits the physical characteristics of open-hearth basic steel of the various grades, the results derived from an extensive series of tests indicating the tendency of a total average of the composition hereafter described to approximate to the figures given in the table.

“The predominant elements other than carbon averaged throughout the series as follows: manganese, .40; phosphorus, .04; sulphur, .05 per cent. Any increase of these elements is attended with an increase of tensile strength and reduced ductility, and *vice versa*. The tensile strength of the steel is also affected to some extent by the temperature at which it is finished, and the rate of cooling; these influences being more apparent in the grades containing highest carbon. Therefore the values given have only a general significance, and the results of individual tests may vary widely above or below the figures in the table.

“For Bessemer or open-hearth acid process steel, the tensile strength will ordinarily be greater for the same percentage of carbon given in this table, for the reason that the proportions of phosphorus and sulphur, and sometimes manganese, are usually higher than in open-hearth basic steel, each

of these elements contributing to strength and hardness in the steel."

OPEN-HEARTH BASIC STEEL.

Percentage of Carbon.	Tensile Strength in Pounds per sq. in.		Ductility.	
	Ultimate Strength.	Elastic Limit.	Stretch in 8 inches.	Reduction of Fractured Area.
.08	54,000	32,500	32 per cent.	60 per cent.
.09	54,800	33,000	31 " "	58 " "
.10	55,700	33,500	31 " "	57 " "
.11	56,500	34,000	30 " "	56 " "
.12	57,400	34,500	30 " "	55 " "
.13	58,200	35,000	29 " "	54 " "
.14	59,100	35,500	29 " "	53 " "
.15	60,000	36,000	28 " "	52 " "
.16	60,800	36,500	28 " "	51 " "
.17	61,600	37,000	27 " "	50 " "
.18	62,500	37,500	27 " "	49 " "
.19	63,300	38,000	26 " "	48 " "
.20	64,200	38,500	26 " "	47 " "
.21	65,000	39,000	25 " "	46 " "
.22	65,800	39,500	25 " "	45 " "
.23	66,600	40,000	24 " "	44 " "
.24	67,400	40,500	24 " "	43 " "
.25	68,200	41,000	23 " "	42 " "

“Distinguishing Terms.—For convenient distinguishing terms, it is customary to classify steel in three grades; ‘mild or soft,’ ‘medium,’ and ‘hard,’ and although the several grades blend into each other, so that no line of distinction exists, in a general sense the grades below .15 per cent. carbon may be considered as ‘soft’ steel; from .15 to .30 per cent. carbon as ‘medium’; and above that, ‘hard’ steel. Each grade has its own advantages for the particular purpose to which it is adapted. The soft steel is well adapted for boiler-plate and similar uses, where its high ductility is advantageous. The medium grades are used for general structural purposes, while harder steel is especially adapted for axles and shafts, and

any service where good wearing surfaces are desired. Mild steel has superior welding properties as compared with hard steel, and will endure higher heat without injury. Steel below .10 per cent. carbon should be capable of doubling flat without fracture after being chilled from a red heat in cold water. Steel of .15 per cent. carbon will occasionally submit to the same treatment, but will usually bend around a curve whose radius is equal to the thickness of the specimen; about 90 per cent. of specimens stand the latter bending-test without fracture. As the steel becomes harder, its ability to endure this bending-test becomes more exceptional, and when the carbon ratio becomes .20 per cent., little over 25 per cent. of specimens will stand the last-described bending-test. Steel having about .40 per cent. carbon will usually harden sufficiently to cut soft iron and maintain an edge."

The classification of steel seems to the average layman a little arbitrary. As shown in the preceding quotation, "For convenient distinguishing terms, it is customary to classify steel in three grades, etc." The classification according to the manufacturers' standard specifications is that "Steel shall be of four grades: 'extra soft,' 'fire-box,' 'flange or boiler,' and 'boiler-rivet' steel. Commercially, and as quoted in the trades papers, the classification is as follows: 'tank,' 'shell,' 'flange,' 'ordinary fire-box,' and 'locomotive fire-box.'"

In reply to an inquiry as to the average physical and chemical properties of each of the commercial grades, one of the largest testing-laboratories in the United States writes as follows: "While we, of course, keep records of all tests made by us, they are not tabulated nor averaged. We doubtless have on record several hundred thousand tests of all grades of material made from nearly all the different steel works in the country. We can, however, give you approximately what the different grades of steel run, as follows:

" MEDIUM STEEL (TANK).

Tensile strength.....	60,000 to 68,000 lbs. per sq. in.
Elastic limit, one-half the ultimate strength.	
Elongation.....	20 to 23%
Reduction of area.....	40 " 45%

Chemical requirements for phosphorus and sulphur same as for " soft steel."

" SOFT STEEL (SHELL).

Tensile strength.....	54,000 to 62,000 lbs. per sq. in.
Elastic limit, one-half the ultimate strength.	
Elongation.....	25%
Reduction of area.....	50%
If acid open-hearth steel : phosphorus under.....	.085%
" " " sulphur under.....	.065%
If basic open-hearth steel : phosphorus under.....	.035%
" " " sulphur under.....	.04%

" FLANGE STEEL.

Ultimate tensile strength.....	54,000 to 62,000 lbs. per sq. in.
Elastic limit, not less than.....	33,000 lbs.
Elongation.....	27%
Reduction of area.....	50%
If acid open-hearth steel :	
Phosphorus not more than.....	.065%
Sulphur not more than.....	.05%
If basic open-hearth steel :	
Phosphorus not more than.....	.035%
Sulphur not more than.....	.035%

" FIRE-BOX STEEL.

" To be made of acid open-hearth steel of the following strength :

Ultimate tensile strength.....	56,000 to 64,000 lbs. per sq. in.
Elastic limit.....	33,000 lbs.
Elongation.....	28%
Reduction of area.....	56%
Phosphorus.....	.035%
Sulphur.....	.035%

" LOCOMOTIVE FIRE-BOX STEEL.

[NOTE.—Specifications of Baldwin Locomotive Works.]

Tensile strength, 55,000 to 65,000 lbs. per sq. in.

Elongation, 20 to 25 per cent.

Carbon, .15 to .25 per cent.

Phosphorus, not over .03 per cent.

Manganese, not over .45 per cent.

Silicon, not over .03 per cent.

Sulphur, not over .035 per cent.

All plate to be manufactured by the open-hearth process.

" RIVET STEEL.

Tensile strength..... 50,000 to 60,000 lbs. per sq. in.

Elastic limit, one-half the ultimate strength.

Elongation. 25 to 28%

Reduction of area..... 50 to 55%

If acid open-hearth steel :

Phosphorus not more than..... .075%

Sulphur not more than..... .06%

If basic open-hearth steel :

Phosphorus not more than..... .035%

Sulphur not more than..... .04%

" BOILER-RIVET STEEL.

" Same as rivet steel, except that a lower percentage of sulphur and phosphorus should be asked for, and also a slightly greater elongation and reduction."

Owing to the comparatively small quantities of rivets required in stand-pipe construction, tests for rivet-rod metal are hardly practicable, and therefore specifications governing same being useless, it would seem that the practical method of securing a suitable grade of rivet metal is to purchase by the keg of manufacturers who have a standing reputation as rivet makers, and for this certain field-tests should be required.

Specifications.—In discussing the suitability of the several grades of steel for stand-pipe construction work, Prof. Pence

has this to say: "The usual market grades of steel plate may be described as follows: Tank steel is the cheapest grade. Its low price is due primarily to the grade of stock used, giving a metal with high percentages of the detrimental elements, even without the careless manipulation which cheap work is so apt to receive. The quality of the tank steel produced by a few makers is sometimes quite good, but experience has shown it to lack uniformity, and good authorities generally agree in condemning its use in important structures. While it may display the physical excellence of the best grades of steel, 'it is apt to be hard and brittle, and should never be used in any part of a stand-pipe.' It is believed by some that a fruitful cause for the treachery of tank steel is to be found in the practice of selling under that classification steel plate which has been rejected from higher grades. It is common to find merely the tensile strength of this grade of steel specified, '60,000 T. S.' being the usual requirement.

"Shell steel is the next better grade. Its greater excellence and enhanced cost are due to the use of more care in selecting the stock and in perfecting the chemical nature of the finished product. Shell steel is used in ordinary boiler-construction, and many stand-pipes have been built from it. It is, of course, preferable to tank steel, but the best practice demands a better grade for high quality boiler and stand-pipe construction. . . . Flange steel, the next grade above shell steel, is distinguished by its uniformity, high ductility, and usually low tensile strength. It is the grade of steel plate adopted in the best practice for the construction of steam-boilers and stand-pipes. . . . Ordinary fire-box and locomotive fire-box are still higher grades of steel boiler-plate, possessing special properties which fit them for the uses indicated by their trade designations."

The matter of cost naturally has a distinct influence upon the selection of grades of materials to be used in stand-pipe

construction, and a comparison is therefore of interest. In July of the present year (1900), a large manufacturer of boilers and stand-pipes writes as follows:

“ In regard to the price of steel plates, would advise

Tank steel, under $\frac{3}{16}$ in. at mill.....	\$1.15
“ “ above $\frac{1}{4}$ in. at mill.....	1.10
Shell steel.....	1.20
Flange steel.....	1.25
Fire-box steel.....	1.30 to 2.85
Rivets.....	1.80

In addition to the chemical and physical specifications for fixing the requirements for different grades of steel, it is considered good practice to stipulate certain bending and drift tests, depending upon the nature of the work for which the steel will be used. The Testing Laboratory, before quoted, writes in this connection, “ These tests frequently reject material more than other requirements, as they more clearly show whether the material will stand the strain for which it is intended.”

The specifications for plate suggested by Prof. Pence for stand-pipe material is as follows: “ *Material.*—The material composing the stand-pipe shall be soft, open-hearth steel, containing not more than 0.06% phosphorus, and having an ultimate tensile strength of not less than 54,000, nor more than 62,000, lbs. per sq. inch; an elastic limit not less than one-half the ultimate strength, an elongation of not less than 26% in 8 inches, and a reduction of area of not less than 50% at fracture, which shall be silky in character. Before or after being heated to a cherry red and quenched with water at 80 deg. F., the steel shall admit of bending while cold, flat upon itself, without sign of fracture on the outside of the bent portion.”

The requirements above are the result of wide investigation by Prof. Pence, and plate filling these specifications

would certainly prove a suitable material, whilst the stipulations are not so severe as to appear too arbitrary or such that there should be any difficulty upon the part of the manufacturer in filling the order, hence the market quotation upon such plate should be sufficiently reasonable as to permit of its use for such structures.

Practically the steel called for by Prof. Pence is a "flange steel," worth, according to the quotations above cited, \$1.25 per 100 lbs. f. o. b. at mill. One of the best authorities in the United States writes as follows regarding structural steel for stand-pipe work:

"In the matter of stand-pipe construction, the quality of the steel depends a good deal on the size of the stand-pipe. That is, on the thickness and size of the plates which you are to use. Also whether you are going to drill and ream the material. Roughly speaking, the specifications should be about as follows:"

"Soft open-hearth steel; to be either acid or basic; tensile strength, 54,000 to 62,000 lbs.; elastic limit not less than 33,000; elongation, 26%; reduction of area, 50%; sulphur, if acid open-hearth steel, less than .06%; phosphorus less than .075%. If basic open-hearth steel, phosphorus to be under .035 and sulphur under .035%. Bend tests should be made on strips about $1\frac{1}{2}$ in. wide, planed parallel, and then should be bent 180 degrees flat upon themselves without showing sign of fracture on either the convex or concave side of the curve. This test should be carefully carried out on each plate. Certain drift tests should also be made; that is, a hole 15-16 in. in diameter, or whatever size the rivet-hole is, should be drifted to twice its size without cracking or injuring the plate."

This authority practically agrees with the conclusions ascribed to Prof. Pence as to the quality of steel suitable for stand-pipe work. As has been shown, the thickness of plate affects the physical properties, and should therefore, it appears

to the author, be considered in the preparation of a set of specifications. In this connection, and quoting from the "Manufacture and Properties of Structural Steel:" "The effects caused by variations in rolling temperatures appear in their most marked degree in the comparison of plates of different gauges. It is not customary to test the same heat in several sizes, but by long experience the manufacturer is able to judge the relative properties of each thickness. The heads of two widely known plate mills have given me their estimate that, taking one-half inch as a basis, there will be the following changes in the physical properties for every increase of one quarter of an inch in thickness:

(1) A decrease in ultimate strength of 1000 pounds per square inch.

(2) A decrease in elongation of one per cent., when measured in an 8 in. parallel section.

(3) A decrease in reduction of area of two per cent.

It is therefore plain that in writing specifications some allowance must be made for these conditions, since a requirement which is perfectly proper for a three-eighths inch plate will be unreasonable for a plate of one and a half inches.

"Moreover the effect is cumulative, since a hard steel must be used in making the thick plate, and this will tend to lessen the difficulty rather than make up for the reduction caused by the larger section. In plates below three-eighths of an inch in thickness it is also necessary to make allowances, since it is almost impossible to finish them at a high temperature, and the test will give a high ultimate strength and a low ductility."

Whilst it may appear unnecessary to exact as a prerequisite the percentage of permissible alloys, other, perhaps, than phosphorus and sulphur, it may not be amiss to include in the specifications, certain requirements as to silicon and manganese.

In the "Manufacture and Properties of Structural Steel"

appears a table compiled from a number of tests of groups of specimens from both acid and basic manufacture, and from this table, two groups of .109 % carbon steel show the other elements as follows:

(1) Silicon	.008;	Manganese,	.310;	Sulphur,	.036;	Phosphorus,	.066	
(2) " "	.007;	" "	.380;	" "	.048;	" "	.082	
Ultimate strength of specimen	No. 1 (acid)						57,310 lbs.	
" "	" "	No. 2 (basic)						57,430 "

According to table showing graduations of steels in relation to their percentages of carbon, it will be seen that this steel will grade as "soft"; ultimate strength, 56,500; elastic limit, 34,000 lbs.; stretch in 8 in., 30%; reduction of fractured area, 56%.

It is impossible at this time to reconcile all conclusions, and theoretical and scientific considerations must be moulded more or less to fit commercial standards, which have been largely set by the Association of American Steel Manufacturers, whose standard specifications are the result of much careful consideration and study.

Deviations from these regulation specifications will be found to entail additional expense to the consumer, possibly not warranted by assumed theoretical conditions, and therefore, in the matter of physical test of steel required, the wording of the specifications "to conform to the standard specifications of the Association of American Steel Manufacturers," would undoubtedly cover the general physical requirements for a serviceable steel which should be "soft," 52,000 to 62,000 lbs. tensile strength per square inch.

In the matter of the chemical specifications, this properly comes within the province of the engineer, and the following is suggested:

CHEMICAL SPECIFICATIONS.

The plate metal to be used in stand-pipe construction shall be the product of some well-established and reputable

mill employing the "open-hearth process of manufacture," a preference being given to acid furnace-lining methods.

The chemical qualifications for this metal shall be such as to ensure the reduction of the metalloids to the following limiting maximum percentages in the finished product :

Phosphorus, .08; Sulphur, .05; Manganese, .60; Silicon, .04.

Drillings for chemical analysis may be taken either from test-piece or finished product, and if required, each of the elements may be ordered determined.

The simple tests of bending and drifting should be inserted into the specifications for structural metal. It should be provided that from any melt or number of melts, test-specimens, as strips, might be cut from the plate. Such strips should be about $1\frac{1}{2}$ inches in width, should be planed parallel, and, when bent 180 degrees upon itself, either hot or cold, should fracture appear upon either the concave or convex surfaces of the curve, the melt may be subject to rejection. Rejections should also be provided for if the material will not stand, without injury, drifting a hole in test pieces to twice the original diameter. Such holes are ordinarily about $\frac{1}{16}$ in.

Inspection.—That there may be no uncertainty or disappointment as to results, it is necessary not only that the constructive engineer shall know what to specify in ordering materials, but he must be reasonably sure that he is getting what he requires. No field-inspection or cursory examination can be relied upon to reveal departures from the specifications and fatal defects, and absolute certainty as to results can only be secured through a close, systematic inspection during the process of manufacture from the raw material to the finished structure; it is obvious, therefore, that such careful attention to details requires the constant presence of a skilled inspector at the mill, the shop, and in the field. A knowledge of and the ability to conduct the necessary series of chemical and

physical tests is rarely possessed by the designing and constructing engineer, even though it were possible for him to give his personal attention to these details, hence, very properly, such work is now entrusted to an assistant making a specialty of such work, or most usually to some reputable inspection-bureau, the outgrowth of this condition.

The necessity for, and extent of, this practice is clearly explained in a recent paper entitled "Shop and Mill Inspection," by Mr. W. O. Henderer, read before the Civil Engineers' Club of Cleveland, and from which the following is quoted:

"There was a time when one man could comfortably attend to such duties himself, and personally follow the progress of the material in all its various processes. The shops and mills at which iron was manufactured, and where the finished parts of structures were produced, were often one and the same; or, if not, the processes followed each other in such rotation that one man could get from mill to shop and keep proper consecutive track of the work. But the industry has of late years grown to such enormous proportions and has extended over such a large area that it is impossible for one man to properly inspect the work in all its stages. Bridge companies now have a number of mills from which to order the material necessary for their work. They are likely to have plates from one mill, beams and channels from another, and other shapes from still a third; and the mills are often great distances apart. Frequently, too, the shop is at work on some portions of a contract while the mills are still furnishing materials. It is manifestly out of the question for any one man to thoroughly inspect work at all these places at one time. He must have assistance in some way.

"Men who have become expert and experienced in this sort of work have made inspection their particular business, performing this service at a compensation based on the ton-

nage in the work, instead of entering the service of the engineer or architect in charge at a salary. Such men, as they found it impossible to economically perform their duties personally on account of the excessive expenses of travelling about, adopted the method of reciprocating among themselves, an inspector in Pittsburg undertaking to do the mill-inspection on one piece of work for another located in Philadelphia, while the latter attended to shop-inspection at shops in his vicinity for the former. Naturally, from such alliances among inspectors, there has resulted the formation of inspection-bureaus or companies. Such companies employ men permanently at the various mills and shops, and maintain extensive general offices, at which the clerical work of copying and forwarding reports and tests, progress of work, etc., is performed. By securing large quantities of inspection work they are able to keep good men at all the localities necessary, maintaining a perfect system of effective inspection and giving their clients regular reports of the quality of material and workmanship, the progress of the work, and information as to tests, shipments, etc., which, when completed, comprises an accurate record of the structure in question, and surety that it is built as it should be. . . . The employment of competent inspection-bureaus becomes more and more general as the iron and steel industry increases in volume, and competition amongst the manufacturers grows keener. Men are realizing more and more forcibly the necessity for such services in order to secure good results. The day when people thought that because a bridge was built of iron it would stand indefinitely is past and gone. Men are finding that there is good and bad iron and steel, and that there is a great difference between them—often the difference between success and failure, between a strong, stiff, and durable structure and an accident costing human life—that it pays to spend the small added cost to insure the use of good material and to detect and exclude the bad.

“ It is remarkable that so many fail to see that specifications and inspection must always go hand in hand; that neither can confer the benefits it should without the other. Most people realize that if no specifications are stated to indicate the nature and quality of the structure desired, the manufacturer cannot be blamed if the structure does not meet the expectations of the purchaser. But often little thought is given to the second part of the purchaser's duty, that of inspection. It is not recognized as a duty owed by every purchaser for his own protection and safety, and to secure benefits from a carefully compiled specification. When the millennium is reached, when it may be reasonably expected that every man's work will be perfect and each one's labor as valuable as that of his fellows, then there will be no difference between good and bad, no possibility of errors or mistakes or dishonesty. When that time arrives there will be no further use for either specifications or inspection, and many a busy man will lose his job. But until that time there will be varying grades in the quality of materials and workmanship, and the necessity for specifying the grade desired on any piece of work will remain.

“ And just so long as there is any cause or reason for specifications, just so long will the inspector be needed to see that the specifications are carried out.”

Concerning the character of the inspection and cost for same, Mr. Henderer continues: “ There are a few inspection-bureaus who are striving for the improvement of inspection services, through the establishment of carefully devised systems for the thorough handling of the work and the employment of only experienced and thoroughly reliable men. Such companies can and do give the quality of service that makes inspection thoroughly valuable. But they have thus far found themselves seriously handicapped by the many irresponsible inspectors who undertake work at ridiculously low

prices without any idea of doing it as it should be done. Engineers and architects are not a little to blame for this state of things, since too many of them fail to consider the inspection service as one having degrees of quality. They have become accustomed to consider that all inspection is the same, and to require that each inspector who makes application for their work shall submit his prices in competition with any one else who may be an applicant, and then employ the man with the lowest price without taking the trouble to properly investigate the comparative facilities or reputations of the applicants.

“It cannot be expected that the best results of inspection will be gained by crowding the price for such services down to the lowest possible figure. There is a limit below which good inspection cannot be performed. The only way in which an engineer can get the full benefit that inspection can confer is to determine at the outset to pay a fair price for that service, and then, before appointing an inspecting firm, to look carefully into the reputations of the different inspecting companies available, by references to other engineers and to pieces of work that have been inspected by them.

“Thorough and complete inspection of iron and steel structural material should generally be worth one dollar per net ton of shop shipping-weights. At times, and under especially favorable conditions as regards the location of the bureau's employés, it can be done for less. On some small jobs it may be more, but there is in general a chance for the inspector to make a fair living at that average price. Such inspection should include the careful comparison and checking of working plans, and complete supervision and tests by thoroughly experienced, expert, and reliable men throughout the manufacture of the material from the time it is first produced until it is shipped from the shop.”

CHAPTER IV.

STRESS OR STRAIN.

“STRESS” or “strain” is the name designating the application of forces to a body in the same straight line but in opposite directions, so that the internal resistance offered by the cohesive force of the fibres or particles of which the body is composed is balanced by the opposing or exterior force or pressure.

The effect of an exterior force acting upon a body to change its shape, may be exerted as “tension,” “compression,” or “shear.”

If the force acting upon a body has a tendency to elongate or stretch its fibres to the point of rupture by pulling them apart, this force is termed a “tensile stress.”

If, on the contrary, the application of the force tends to shorten or to compress these fibres, such force is called a “compression stress,” obviously “compression” and “tensile” stresses differ only as regards the direction in which the exterior force is applied or exerted upon the fibres of which the body consists.

Force applied so as to act longitudinally along any “member” of a structure through its fibres, tends either to elongate or to compress these fibres in direct proportion to the pressure exerted, and the resistance offered to this pressure by the fibres themselves is also directly proportional to the tenacity and number of the fibres of which the body is composed. as represented by its area or “cross-section.”

Beside these two stresses, there is a third, called a “shear stress,” and which, as its name would indicate, is the tendency

of the external force to cut in twain or to shear the fibres, and is the application of the forces in vertical planes at right angles to the fibres, or through the cross-section of the body.

The consideration and understanding of these stresses in the material and members of such structures as towers, tanks, and the like, and a knowledge of the resistance which the character of the material, its dimensions, and shape, will offer in opposition to extraneous forces is of the utmost importance.

The manner or method of the application of force to a body necessarily comprehends a principle of mechanics known as the "moment" of forces, or the tendency of a force to produce motion about a point. This is an expression representing the power produced by the force to cause motion about a point when acting through the principle of "leverage."

In the consideration of the stability of a structure or its ability to resist a sliding, horizontal motion, or a tendency to overturn about its toe, the consideration and application of the principles of "leverage," and the opposing force exerted by the natural law of gravitation, must be carefully analyzed and observed.

Moment of Forces.—The "moment" of a force is the product of the force by its leverage; thus, if the force or pressure be represented by pounds, tons, etc., and the leverage of the force, or the perpendicular or shortest distance from its "fulcrum" to the direction through which the force is acting is expressed in feet, this product is termed the "moment" of the force about the given point, and may be expressed as "foot-pounds" or "foot-tons."

If any force, as 10 pounds, 10 tons, etc., be exerted through a leverage of any number of feet, say 20, the resultant, 10×20 equals 200 feet-pounds or feet-tons.

The resistance which the weight of a structure, acting ver-

tically through its centre of gravity, offers to an applied force through its leverage and tending to change its position determines its "stability of position."

Equilibrium.—Forces are said to be in "equilibrium" when they equal or balance each other, each preventing the other from imparting motion to the body; so also forces, when multiplied by their respective leverages, are said to be in equilibrium when the action which each exerts maintains the body at rest, and it may be observed that the moment of forces about a point may hold each other and establish the equilibrium of the body even though the forces themselves fail to balance. Two opposing forces, or the moment of these forces, acting at the same time equally upon an unresisting body, neutralize or destroy each other, the body is at rest and equilibrium is said to exist. Should one force, or the moment of that force, exceed the other, equal parts of each force destroy each other and any excess of the one over the other is termed the "resultant" of the two forces; and the direction of this excess, or the resultant of the two forces, is exerted in a line bisecting the original angle at which the forces met, and the extent of the force exerted by this resultant is the difference between that offered by the two or more original forces, or the moment of those forces.

Resistance to Overturning.—In analyzing the stability of any structure such as a stand-pipe, the effect of the pressure exerted by the wind against the sides of the tank is to cause motion by a sliding, horizontal movement, and to produce overturning about the toe or base. This tendency is resisted by the weight of the tank itself, acting vertically through its centre of gravity and upon the area of its base. The disposition toward moving horizontally upon its base is opposed by the roughness of the parallel faces in contact, as the bottom plates of the tank and the upper face of the foundations, and is found by multiplying the perpendicular pressure by the "coefficient of friction," but as against the action of the

wind upon the sides of a stand-pipe, the vertical pressure exerted even by the weight of the empty tank over the area of its base, is usually sufficient to restrain the force exerted by the wind and to keep the structure at rest even without the customary anchorage, therefore this tendency will not be given further consideration here.

The effect which wind exerts upon cylindrical structures such as a stand-pipe has never been determined with any degree of certainty, but Trautwine has the following:

Wind Pressure.—“ The relation between the velocity of wind and its pressure against an obstacle placed either at right angles to its course, or inclined to it, has not been well determined, and still less so its pressure against curved surfaces. The pressure against a large surface is probably proportionately greater than against a small one. It is generally observed to vary nearly as the square of the velocities, and when the obstacle is at right angles to its direction, the pressure in pounds per square foot of exposed surface is considered to be equal to the square of the velocity in miles per hour, divided by 200. On this basis, which is probably quite defective, the following table, as given by Smeaton, is prepared: ”

Velocity in Miles Per Hour.	Velocity in Feet Per Second.	Pressure in Pounds Per Square Foot.	Remarks.
1	1.467	.005	Hardly perceptible. Pleasant.
2	2.933	.020	
3	4.400	.045	
4	5.876	.080	
5	7.33	.125	
10	14.67	.5	Fresh breeze.
12½	18.33	.781	
15	22.	1.125	
20	29.33	2.	
20	36.67	3.125	
30	44.	4.5	Brisk wind. Strong wind.
40	58.67	8.	
50	73.33	12.5	Storm. Violent storm.
60	88.	18.	
80	117.3	32.	Hurricane. Violent hurricane.
100	146.7	50.	

The formula employed by Smeaton in the preparation of the foregoing table, and where P = pressure in pounds per square foot of surface and V = velocity of the wind in miles per hour, was $P = 0.0050V^2$.

The U. S. Water Bureau uses the same formula except that the coefficient is made 0.0040.

The coefficient used was determined experimentally by exposing squarely against the wind plates of from four to nine square feet of surface and recording simultaneously the velocity of the wind and its resulting pressure.

The anemometer, the instrument used for measuring wind velocities, gives readings which only approximate the real velocities, the latter being found by correction. The following table, taken from a circular issued by the U. S. Department of Agriculture, Weather Bureau, gives the recorded or indicated velocities, their equivalent corrected velocities, and the corresponding pressures.

TABLE OF WIND PRESSURES.

Indicated Vel.	True Vel.	Pounds Pressure.
10 miles.	9.6 miles.	0.369 per sq. ft.
20 "	17.8 "	1.27 " " "
30 "	25.7 "	2.64 " " "
40 "	33.3 "	4.44 " " "
50 "	40.8 "	6.66 " " "
60 "	48.0 "	9.22 " " "
70 "	55.2 "	12.20 " " "
80 "	62.2 "	15.50 " " "
90 "	69.2 "	19.20 " " "

Prof. C. F. Marvin, of the Weather Bureau, states that velocities beyond 50 to 60 miles an hour are not accurately recorded by the anemometer, and that exact information is therefore impossible, although cases are reported where the anemometer has continuously indicated velocities as great as 80 to 100 miles per hour, but exact data for interpreting such indications

does not exist; therefore the exact wind movement cannot be reduced. Occasionally, during the thunder-storms and gusts of summer, anemometers will record for a brief period velocities up to 75 miles an hour; but in such cases the storms and gusts are of short duration. It is, however, reported that at some seacoast stations and at Mount Washington, N. H., velocities as great as 100 miles per hour have been continuously recorded during pronounced storms. Occasionally during storms, sudden and violent gusts of wind occur, considerably greater than the indicated or mean velocities. The impact of such gusts upon engineering structures are likely to set up coincident vibration out of proportion to the effect of the recorded velocities of the wind. In an article in the *Engineering News*, Dec. 13, 1890, Prof. Marvin states that momentary pressures as great as 35% in excess of the recorded mean pressures may continually occur and recur, and if their rate of occurrence be at all synchronous with the natural time of vibration of the structure or any part thereof, remarkable results may follow. The greatest velocity so far registered is reported from the signal station at Point Reyes, Cal., where on May 18, 1902, a wind velocity of 102 miles an hour was registered, and for several moments the anemometer recorded a velocity of 120 miles an hour, the violence of the storm finally ripping the cups from the instrument. During 72 hours, the record was 4701 miles.

The assumption given above, that the pressure of the wind acting upon a semi-cylindrical surface is equal to one half that which would be exerted upon a flat surface, having an area equal to that of the diametral plane of the cylinder, is generally accepted as nearly correct by the best authorities, and accords with the recommendation of Rankine in *Applied Mechanics*.

In assuming the maximum pressure of the wind, it is considered good practice to accord it a pressure of about 30

lbs. per square foot and estimated as being exerted upon the vertical plane as projected through the centre of gravity of a cylindrical structure; thus, to estimate the maximum pressure of the wind exerted upon the semi-cylindrical sides of a stand-pipe 20 ft. in diameter and 120 ft. in height, $20 \times 120 \times 30$ lbs. equals 72,000 lbs. or 36 tons, and the moment of this force, or the pressure in tons multiplied by its leverage, or its distance from the centre of gravity about the point, is 60 ft. \times 36 tons, or 2,160 ft.-tons.

The resistance offered to this overturning moment is the weight of the structure, in tons, multiplied by its leverage, or its perpendicular distance from its centre of gravity at its base to the point or toe, and as the centre of gravity of a cylinder is the centre of the circle, the leverage is therefore

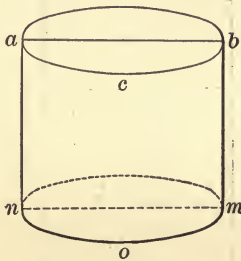

FIG. 8.—The pressure against a semi-cylindrical surface $abcnom$ is about one half that against the flat surface $abnm$.

its radius, or in this case 10 ft., so that the moment of this force is its weight, say 80 tons, multiplied by its lever-arm, 10 ft., or 800 ft.-tons, therefore the resultant of these two moments shows an excess of 1360 ft.-tons, in amount and tendency sufficient to render the structure unstable or to cause its overturning. In order, therefore, to render such a structure stable upon its foundations, it will be necessary to provide a suitable anchorage. In order to show the instabil-

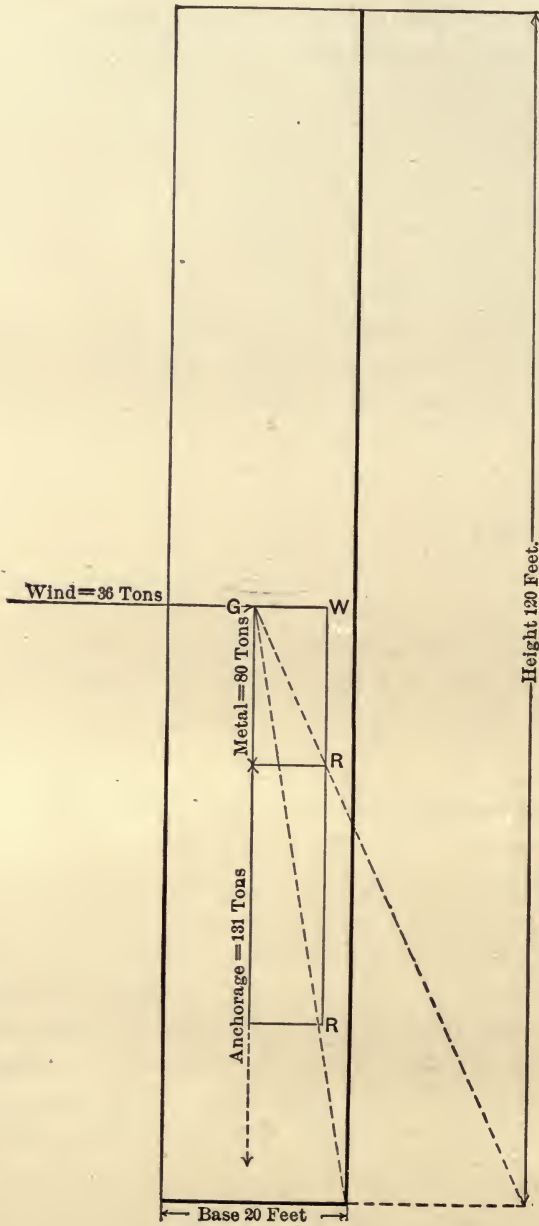

FIG. 9.

ity of such a structure graphically, lay off, by scale, a figure 20×120 , denoting its centre of gravity G . Draw the horizontal line GW to any convenient scale, representing the estimated force of the wind in tons. By the same scale, draw a vertical line, GV , showing the direction and amount of the vertical forces due to the weight of the structure. Complete the parallelogram of forces as shown, and the diagonal, GR , will represent the direction and extent of the combined action of the vertical and horizontal forces, and, if produced, falls without the figure or beyond its base. Here the structure can not stand.

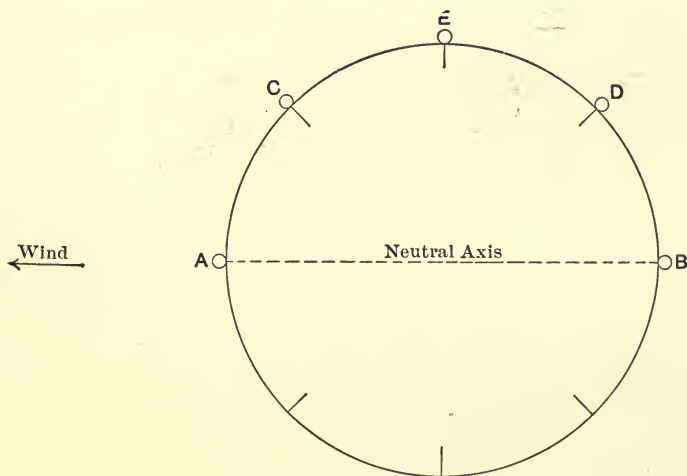

FIG. 9a.

In order to secure the equilibrium of the structure it is evident that some form of anchorage must be provided. Considering the wind-stress to which the tank may be subjected, the moment of this force M , is 72,000 lbs. multiplied by the leverage in inches, 720, or 51,840,000 pounds-inches.

The area of the tank cross-section in inches being 45,239,

the maximum bending moment per square inch of circumference $S, = \frac{M}{A}$; or 1146, which value multiplied by the length of



FIG. 9b.—Anchorage for 24 ft. \times 70 ft. Stand-pipe.

the arc between anchors (753.96 inches divided by the number of rods, say 8) gives 94.24 inches, which multiplied by the bending moment 1146 gives 107,599 lbs. as the total wind reaction

on any one rod. Against this wind pressure the force of the load due to the tank weight or metal is opposed and must be considered.

If W = the total "dead" load (160,000 lbs.) and the number of rods, $N=8$, then the net maximum reaction will be $\frac{W}{N} \pm$ wind reaction or 87,599 lbs. in the case under consideration.

The maximum reaction will occur at E , Fig. 9a, when the wind is as shown.



FIG. 9c.—Connection Details.

Assuming 15,000 lbs. as a safe working value or allowable stress for the rod metal, we have $\frac{87,599}{15,000} = 5.833$ square inches of rod cross-section and the nearest approximate size is $2\frac{3}{4}$ inches. The anchors at A and B , Fig. 9a, being on the neutral axis when the wind is as shown, receive no longitudinal strain as no fiber stresses occur at the neutral axis within the elastic limit, and the pull on the rods C' and D is $S = \frac{1}{8} \frac{M}{A} - \frac{W}{8}$.

Assuming that the three rods, *C*, *D* and *E*, are in tension and are capable of exerting a holding down value of 87,599 lbs. each, the three would exert an effect equal to approximately 131 tons, which would be added to the dead weight and measured along the vertical line *G-V*, Fig. 9, proving graphically the stability of structure.

The maximum stress per circumferential inch is the bending moment divided by the area, or, $S + M \div A$; this value when multiplied by the length of the arc between anchor rods gives the maximum wind-stress on each rod. The *net* stress is found by dividing the weight of metal by the number of rods and subtracting from the maximum stress, thus $S = M \div A - W \div N$.

Hydrostatic Pressure.—In addition to the external pressure exerted by the wind, stand-pipes are subject to, and must be designed to resist, an internal pressure of water with which they will be filled, or to resist the "Hydrostatic Pressure." From experiment it has been found that the maximum density of water occurs at from 6 degrees to 7 degrees above freezing point, from which point its density decreases and volume increases with each degree of advancing temperature.

At the level of the sea, the approximate atmospheric pressure of $14\frac{1}{2}$ lbs. per sq. in. will balance a column of water 34 ft. in height. The weight of water is approximately $62\frac{1}{2}$ lbs. per cubic foot, and is usually so taken for the purpose of calculation. A cubic foot of water, in a cubical receptacle, exerts a pressure over the base of 144 sq. inches, equivalent to its weight; so then, the pressure of $62\frac{1}{2}$ lbs. of water over 144 sq. inches ($\frac{62.5}{144}$) equals 0.433507 lbs.; hence, to find the pressure of any column of water, multiply the height or "head" in feet by .434; very roughly, divide the given head by 2.

Conversely, when the pressure per sq. inch is given, to find the head to which the pressure is due, $\frac{14.7}{0.434}$ equals 2.30677, or roughly, 2.3. The following table may be found useful:

Converting Feet-head of Water into Pressure per Square Inch.		Converting Pressure per Square Inch into Feet-head of Water.	
Feet-head.	Pounds per Square Inch.	Pounds per Square Inch.	Feet-head.
10.....	4.33	5.....	11.54
15.....	6.50	6.....	13.85
20.....	8.66	7.....	16.16
25.....	10.83	8.....	18.47
30.....	12.99	9.....	20.78
35.....	15.16	10.....	23.09
40.....	17.32	15.....	34.63
45.....	19.40	20.....	46.18
50.....	21.65	25.....	57.72
55.....	23.82	30.....	69.27
60.....	25.99	35.....	80.81
65.....	28.15	40.....	92.36
70.....	30.32	45.....	103.90
75.....	32.48	50.....	115.45
80.....	34.65	55.....	126.99
85.....	36.81	60.....	138.54
90.....	38.98	65.....	150.08
95.....	41.14	70.....	161.63
100.....	43.31	75.....	173.17
105.....	45.57	80.....	184.72
110.....	47.64	85.....	196.26
115.....	49.91	90.....	207.81
120.....	51.97	95.....	219.35
125.....	54.25	100.....	230.90
130.....	56.30	110.....	253.98
135.....	58.59	120.....	277.07
140.....	60.63	130.....	300.16
145.....	62.93	140.....	323.25
150.....	64.96	150.....	346.34

In considering the effect of the pressure due to the height or head of water, or "static head," exerted upon the interior surfaces of a cylindrical structure such as a stand-pipe, the explanation given by Trautwine is so concise and clear that it is copied here without further apology:

"In the figure, which represents a vessel full of water, the total pressure against the semi-cylindrical surface *a v e m d k* and perpendicular to it, must be also horizontal, because the surface is vertical; but inasmuch as the surface is *curved*, this

total pressure acts against it in many directions, which might be represented by an infinite number of radii drawn from o as a centre. But let it be required to find the horizontal pressure in lbs. in one direction only, say parallel to oe , or perpendicular to ad , which would be the force tending to tear the curved surface away from the flat sides $abnv$, and $dcsk$, by producing fractures along the lines av and dk , or which would tend to burst a pipe or other cylinder. In this case, multiply together the area of the vertical projection $adkv$ in sq. feet; the depth of the centre of gravity of the curved surface in ft. (which in the semi-cylinder would be half of em , or of oi), and 62.5.

“ Since the resulting pressure is resisted by the strength of the vessel along the two lines av and dk , it is plain that each single thickness along those lines need only be sufficient to resist safely *one-half* of it; and so in the case of pipes or other cylinders, such as hooped cisterns or tanks.”

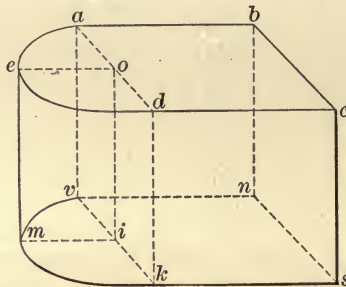

FIG. 10.

Resistance offered by Material.—From the above, it will be seen that a formula for hydrostatic pressure exerted upon the sides of a cylinder would be

$$\frac{D \times H \times 62.5}{2}, \dots \dots \dots (1)$$

where D = diameter of cylinder;
 H = its height in feet.

It has been shown that the pressure exerted upon the bottom of the vessel is in direct proportion to the head of water, or the area, multiplied by the head of the column in pounds.

To resist the internal hydrostatic stresses is opposed the thickness and material of the plate and its riveting in a cylindrical stand-pipe, and to proportion the opposing plate to safely resist the pressure the following factors must be known or assumed: 1st, The tensile strength of the metal; 2d, the percentage of strength of the material; 3d, a reduction of theoretical strength to allow a margin or factor of safety; and 4th, some unit of length must be adopted representing the surface pressed. The unit of length is usually taken for convenience at 12 in. In designing, 60,000 lbs. per sq. in. is generally assumed as the unit stress of the material, and allowance for the decreased value of this unit, due to punching and riveting, is made at about 33 per cent. off, or the working value of a 12 in. section is at $\frac{2}{3}$ of its original strength; reducing the ultimate strength by using a factor of safety of 4 is considered good practice for such metal structures, not subject to shock, hence the formula for proportioning the thickness of plates intended to resist such hydrostatic pressures may be given as

$$\frac{60,000 \times 12'' \times \frac{2}{3}}{4} \dots \dots \dots (2)$$

To proportion the thickness of metal intended to resist the hydrostatic pressure exerted upon the internal surface of any cylinder, divide (1) by (2), therefore the following general expression for the thickness of metal in decimals of an inch for any given diameter of tank and any assumed height:

$$\frac{D \times H \times 62.5}{2} \div \frac{60,000 \times 12'' \times \frac{2}{3}}{4}$$

from the above the following original tables have been computed:

10-FT. DIAMETER CYLINDER.
Circumference, 31.4159; area, 78.5398.

Height.	Capacity, Gallons.	Weight, Pounds.	Pressure, Pounds.	Thickness, Dec. In.	Thickness, Frac. In.
10	5,890	49,087	3,124		
15	8,835	73,631	4,688		
20	11,781	98,175	6,250		
25	14,726	122,718	7,812		
30	17,671	147,262	9,374		
35	20,617	171,806	10,938		
40	23,562	196,350	12,500		
45	26,507	220,892	14,062		
50	29,452	245,437	15,624		
55	32,397	269,981	17,188		
60	35,343	294,524	18,750		
65	38,288	319,068	20,312		
70	41,233	343,611	21,876	.1823	3/16
75	44,179	368,155	23,438	.1953	3/16
80	47,124	392,699	25,000	.2083	13/64
85	50,069	417,242	26,562	.2213	7/32
90	53,014	441,786	28,124	.2344	15/64
95	55,960	466,330	29,686	.2474	15/64
100	58,905	490,874	31,250	.2604	1/4
105	61,850	515,417	32,812	.2751	9/32
110	64,795	539,961	34,374	.2864	9/32
115	67,741	564,505	35,936	.2995	19/64
120	70,686	589,048	37,500	.3125	5/16

11-FT. DIAMETER CYLINDER.
Circumference, 34.5575; area, 95.0332.

10	7,127	59,396	3,438		
15	10,691	89,093	5,156		
20	14,255	118,791	6,874		
25	17,819	148,489	8,594		
30	21,382	178,187	10,312		
35	24,946	207,885	12,032		
40	28,510	237,583	13,750		
45	32,073	267,280	15,468		
50	35,637	296,978	17,188		
55	39,201	326,676	18,906		
60	42,764	356,374	20,624		
65	46,328	386,072	22,344	.1862	3/16
70	49,892	415,770	24,062	.2005	3/16
75	53,456	445,468	25,780	.2146	7/32
80	57,020	475,165	27,500	.2292	7/32
85	60,584	504,864	29,218	.2435	15/64
90	64,147	534,562	30,936	.2578	1/4
95	67,711	564,259	32,656	.2721	9/32
100	71,275	593,957	34,374	.2864	9/32
105	74,839	623,655	36,092	.3007	19/64
110	78,402	653,353	37,812	.3151	5/16
115	81,966	683,051	39,530	.3294	21/64
120	85,530	712,749	41,250	.3438	11/32

12-FT. DIAMETER CYLINDER.
Circumference, 37.6991; area, 113.10.

Height.	Capacity, Gallons.	Weight, Pounds.	Pressure, Pounds.	Thickness, Dec. In.	Thickness, Frac. In.
10	8,483	70,687	3,750		
15	12,724	106,031	5,626		
20	16,965	141,375	7,500		
25	21,206	176,719	9,376		
30	25,448	212,063	11,250		
35	29,689	247,406	13,126		
40	33,930	282,750	15,000		
45	38,171	318,094	16,876		
50	42,413	353,438	18,750		
55	46,654	388,781	20,626		
60	50,895	424,125	22,500	.1875	3/16
65	55,136	459,469	24,376	.2031	13/16
70	59,378	494,813	26,250	.2187	7/32
75	63,619	530,156	28,126	.2335	15/64
80	67,860	565,500	30,000	.2500	1/4
85	72,101	600,844	31,876	.2656	17/64
90	76,343	636,187	33,750	.2809	9/32
95	80,584	671,531	35,626	.2969	19/64
100	84,825	706,875	37,400	.3117	5/16
105	89,066	742,219	39,376	.3281	22/64
110	93,308	777,562	41,250	.3437	11/32
115	97,549	812,906	43,126	.3594	23/64
120	101,790	848,250	45,000	.3750	3/8

13-FT. DIAMETER CYLINDER.
Circumference, 40.8407; area, 132.7323.

10	9,955	82,958	4,067		
15	14,932	124,437	6,094		
20	19,910	165,915	8,126		
25	24,887	207,394	10,156		
30	29,865	248,872	12,188		
35	34,842	290,352	14,218		
40	39,820	331,831	16,250		
45	44,797	373,310	18,282		
50	49,775	414,738	20,312		
55	54,752	456,267	22,344	.1862	3/16
60	59,730	497,746	24,374	.2031	13/64
65	64,707	539,225	26,406	.2200	7/32
70	69,684	580,704	28,438	.2369	15/64
75	74,662	622,183	30,468	.2538	1/4
80	79,639	663,661	32,500	.2708	17/64
85	84,617	705,140	34,532	.2878	9/32
90	89,594	746,619	36,562	.3046	19/64
95	94,572	788,098	38,584	.3216	5/16
100	99,549	829,577	40,626	.3384	21/64
105	104,527	871,056	42,656	.3551	11/32
110	109,504	912,535	44,688	.3724	3/8
115	114,482	954,013	46,718	.3892	25/64
120	119,459	995,492	48,750	.4062	13/32

14-FT. DIAMETER CYLINDER.
Circumference, 43.9823; area, 153.9380.

Height.	Capacity, Gallons.	Weight, Pounds.	Pressure, Pounds.	Thickness, Dec. In.	Thickness, Frac. in.
10	11,545	96,211	4,376		
15	17,318	144,317	6,562		
20	23,091	192,423	8,750		
25	28,863	240,528	10,938		
30	34,636	288,634	13,124		
35	40,408	336,739	15,312		
40	46,181	384,845	17,500		
45	51,954	432,951	19,688		
50	57,727	481,056	21,876	.1822	3/16
55	63,499	529,162	24,062	.2005	13/64
60	69,272	577,268	26,250	.2187	7/32
65	75,045	625,373	28,438	.2369	15/64
70	80,817	673,479	30,626	.2588	1/4
75	86,590	721,584	32,812	.2736	17/64
80	92,363	769,690	35,000	.2916	9/32
85	98,135	817,796	37,188	.3098	19/64
90	103,908	865,901	39,376	.3280	5/16
95	109,681	914,007	41,562	.3464	11/32
100	115,454	962,113	43,748	.3644	23/64
105	121,226	1,010,218	45,936	.3828	3/8
110	126,999	1,058,324	48,124	.4010	13/32
115	132,772	1,106,429	50,310	.4192	27/64
120	138,544	1,155,450	52,498	.4374	7/16

15-FT. DIAMETER CYLINDER.
Circumference, 47.1239; area, 176.7146.

10	13,254	110,447	4,688		
15	19,880	165,670	7,032		
20	26,507	220,893	9,374		
25	33,134	276,117	11,718		
30	39,761	331,340	14,062		
35	46,388	386,563	16,406		
40	53,014	441,786	18,750		
45	59,641	497,010	21,094		
50	66,268	552,233	23,436	.1953	3/16
55	72,895	607,456	25,780	.2146	13/64
60	79,522	662,680	28,124	.2344	15/64
65	86,148	717,903	30,468	.2538	1/4
70	92,775	773,126	32,812	.2730	9/32
75	99,402	828,350	35,156	.2930	9/32
80	106,029	883,573	37,500	.3124	5/16
85	112,656	938,796	39,844	.3320	21/64
90	119,282	994,020	42,188	.3516	11/32
95	125,909	1,049,243	44,532	.3710	3/8
100	132,536	1,104,466	46,874	.3908	25/64
105	139,163	1,159,690	49,218	.4100	13/32
110	145,789	1,214,913	51,562	.4296	27/64
115	152,416	1,270,136	53,906	.4492	29/64
120	159,043	1,325,359	56,250	.4688	15/32

16-FT. DIAMETER CYLINDER.
Circumference, 50.2655; area, 201.0619.

Height.	Capacity, Gallons.	Weight, Pounds.	Pressure, Pounds.	Thickness, Dec. In.	Thickness, Frac. In.
10	15,080	125,664	5,000		
15	22,619	188,495	7,500		
20	30,160	251,327	10,000		
25	37,699	314,159	12,500		
30	45,239	376,991	15,000		
35	52,779	439,823	17,500		
40	60,319	502,655	20,000		
45	67,858	565,486	22,500	.1875	3/16
50	75,398	628,318	25,000	.2083	13/64
55	82,938	691,150	27,500	.2291	7/32
60	90,478	753,982	30,000	.2500	1/4
65	98,018	816,814	32,500	.2708	17/64
70	105,557	879,646	35,000	.2916	9/32
75	113,097	942,478	37,500	.3124	5/16
80	120,637	1,005,309	40,000	.3332	21/64
85	128,177	1,068,141	42,500	.3540	11/32
90	135,717	1,130,973	45,000	.3750	3/8
95	143,257	1,193,805	47,500	.3960	25/64
100	150,796	1,256,637	50,000	.4166	13/32
105	158,336	1,319,469	52,500	.4374	7/16
110	165,876	1,382,300	55,000	.4584	29/64
115	173,416	1,445,132	57,500	.4792	15/32
120	180,956	1,507,964	60,000	.5000	1/2

17-FT. DIAMETER CYLINDER.
Circumference, 53.4071; area, 226.9800.

10	17,023	141,862	5,312		
15	25,535	212,794	7,968		
20	34,047	283,725	10,624		
25	42,559	354,656	13,282		
30	51,070	425,587	15,938		
35	59,582	496,519	18,584		
40	68,094	567,450	21,250		
45	76,606	638,381	23,906	.1992	3/16
50	85,117	709,312	26,562	.2213	7/32
55	93,629	780,244	29,218	.2434	1/4
60	102,141	851,175	31,874	.2656	17/64
65	110,653	922,106	34,532	.2878	9/32
70	119,164	993,037	37,188	.3098	5/16
75	127,676	1,063,969	39,844	.3320	21/64
80	136,188	1,134,900	42,500	.3544	11/32
85	144,699	1,205,831	45,156	.3762	3/8
90	153,211	1,276,762	67,812	.3984	25/64
95	161,723	1,347,694	50,468	.4206	27/64
100	170,235	1,418,625	53,124	.4426	7/16
105	178,747	1,489,556	55,782	.4648	15/32
110	187,258	1,560,488	58,438	.4874	31/64
115	195,770	1,631,419	61,094	.5090	1/2
120	204,282	1,702,350	63,750	.5278	17/32

18-FT. DIAMETER CYLINDER.

Circumference, 56.5487; area, 254.4690.

Height.	Capacity, Gallons.	Weight, Pounds.	Pressure, Pounds.	Thickness, Dec. In.	Thickness, Frac. In.
10	19,085	159,043	5,625		
15	28,628	238,565	8,438		
20	38,170	318,086	11,250		
25	47,713	397,608	14,062		
30	57,255	477,129	16,876		
35	66,798	556,651	19,686		
40	76,341	636,172	22,500	.1875	3/16
45	85,883	715,694	25,312	.2109	7/32
50	95,426	795,215	28,124	.2344	15/64
55	104,968	874,737	30,936	.2578	1/4
60	114,511	954,258	33,750	.2812	9/32
65	124,054	1,033,780	36,562	.3040	5/16
70	133,596	1,113,302	39,374	.3280	21/64
75	143,139	1,192,823	42,186	.3516	11/32
80	152,681	1,272,345	45,000	.3758	3/8
85	162,224	1,351,866	47,812	.3984	25/64
90	171,766	1,431,388	50,624	.4218	27/64
95	181,309	1,510,910	53,436	.4452	7/16
100	190,852	1,590,431	56,250	.4688	15/32
105	200,394	1,669,953	59,062	.4922	31/64
110	209,937	1,749,474	61,874	.5156	1/2
115	219,479	1,828,996	64,687	.5409	35/64
120	229,022	1,908,517	67,500	.5626	9/16

19-FT. DIAMETER CYLINDER.

Circumference, 59.6903; area, 283.5287.

10	21,265	177,205	5,968		
15	31,897	265,808	8,906		
20	42,529	354,411	11,875		
25	53,162	443,014	14,844		
30	63,794	531,616	17,812		
35	74,426	620,219	20,781		
40	85,059	708,822	23,750	.1896	3/16
45	95,691	797,424	26,718	.2226	7/32
50	106,323	886,023	29,687	.2472	15/64
55	116,956	974,630	32,656	.2721	17/64
60	127,588	1,063,232	35,625	.2969	19/64
65	138,220	1,151,835	38,594	.3216	21/64
70	148,852	1,240,438	41,562	.3463	11/32
75	159,485	1,329,041	44,532	.3711	3/8
80	170,117	1,417,644	47,500	.3958	25/64
85	180,750	1,506,246	50,468	.4205	13/32
90	191,382	1,594,849	53,437	.4453	7/16
95	202,014	1,683,452	56,406	.4700	15/32
100	212,646	1,772,054	59,375	.4948	1/2
105	223,279	1,860,657	62,344	.5195	33/64
110	233,911	1,949,260	65,312	.5443	35/64
115	244,543	2,037,862	68,281	.5690	9/16
120	255,176	2,126,465	71,250	.5937	19/32

20-FT. DIAMETER CYLINDER.
Circumference, 62.8318; area, 314.1593.

Height.	Capacity, Gallons.	Weight, Pounds.	Pressure, Pounds.	Thickness, Dec. In.	Thickness, Frac. In.
10	23,562	196,350	6,250		
15	35,343	294,524	9,375		
20	47,124	392,700	12,500		
25	58,905	490,874	15,625		
30	70,686	589,048	18,750		
35	82,467	687,223	21,875	.1823	3/16
40	94,248	785,398	25,000	.2083	13/64
45	106,029	883,573	28,125	.2344	15/64
50	117,810	981,748	31,250	.2604	17/64
55	129,591	1,079,923	34,375	.2865	9/32
60	141,372	1,178,097	37,500	.3125	5/16
65	153,153	1,276,272	40,625	.3385	21/64
70	164,934	1,374,447	43,750	.3646	23/64
75	176,715	1,472,622	46,875	.3906	25/64
80	188,496	1,570,796	50,000	.4166	13/32
85	200,277	1,668,971	53,125	.4427	7/16
90	212,058	1,767,146	56,250	.4688	15/32
95	223,839	1,865,321	59,375	.4948	31/64
100	235,619	1,963,496	62,500	.5208	1/2
105	247,400	2,061,670	65,625	.5469	35/64
110	259,181	2,159,845	68,750	.5729	37/64
115	270,962	2,258,020	71,875	.5989	19/32
120	282,743	2,356,194	75,000	.6250	5/8

21-FT. DIAMETER CYLINDER.
Circumference, 65.9735; area, 346.3606.

10	25,977	216,475	6,563		
15	38,966	324,713	9,844		
20	51,954	432,951	13,126		
25	64,943	541,188	16,406		
30	77,932	649,426	19,688		
35	90,920	757,664	22,969	.1914	3/16
40	103,908	865,902	26,250	.2187	7/32
45	116,897	974,139	29,531	.2461	15/64
50	129,885	1,082,377	32,812	.2734	17/64
55	142,874	1,190,615	36,094	.3008	19/64
60	155,862	1,298,852	39,375	.3281	21/64
65	168,851	1,407,090	42,656	.3554	23/64
70	181,839	1,515,328	45,938	.3828	3/8
75	194,828	1,623,565	49,219	.4101	13/32
80	207,816	1,731,803	52,500	.4375	7/16
85	220,805	1,840,040	55,781	.4648	15/32
90	233,793	1,948,278	59,062	.4922	1/2
95	246,782	2,056,516	62,344	.5195	33/64
100	259,770	2,164,754	65,625	.5469	35/64
105	272,759	2,272,991	68,906	.5742	37/64
110	285,747	2,381,229	72,188	.6015	39/64
115	298,736	2,489,467	75,469	.6289	5/8
120	311,724	2,597,704	78,750	.6562	21/32

22-FT. DIAMETER CYLINDER.

Circumference, 69.1150; area, 380.1327.

Height.	Capacity, Gallons.	Weight, Pounds.	Pressure, Pounds.	Thickness, Dec. In.	Thickness, Frac. In.
10	28,510	237,583	6,875		
15	42,765	356,374	10,312		
20	57,020	475,166	13,750		
25	71,275	593,957	17,187		
30	85,530	712,749	20,625		
35	99,785	831,540	24,063	.2005	3/16
40	114,040	950,332	27,500	.2292	7/32
45	128,295	1,069,123	30,937	.2578	1/4
50	142,550	1,187,915	34,375	.2865	9/32
55	156,805	1,306,706	37,812	.3151	5/16
60	171,060	1,425,498	41,250	.3438	11/32
65	185,315	1,544,289	44,687	.3724	3/8
70	199,570	1,663,081	48,125	.4010	13/32
75	213,825	1,781,872	51,562	.4297	7/16
80	228,080	1,900,663	55,000	.4583	15/32
85	242,335	2,019,455	58,437	.4869	1/2
90	256,590	2,138,246	61,875	.5156	33/64
95	270,845	2,257,038	65,312	.5443	35/64
100	285,100	2,375,830	68,750	.5729	9/16
105	299,354	2,494,621	72,187	.6015	39/64
110	313,609	2,613,412	75,625	.6402	41/64
115	327,864	2,732,204	79,062	.6588	21/32
120	342,119	2,850,996	82,500	.6875	11/16

23-FT. DIAMETER CYLINDER.

Circumference, 72.2566; area, 415.4756.

10	31,161	259,672	7,187		
15	46,741	389,508	10,781		
20	62,321	519,344	14,375		
25	77,902	649,181	17,968		
30	93,482	779,016	21,562		
35	109,062	908,853	25,156	.2096	3/16
40	124,643	1,038,689	28,750	.2396	15/64
45	140,223	1,168,525	32,343	.2695	9/32
50	155,803	1,298,361	35,937	.2995	5/16
55	171,384	1,428,197	39,531	.3294	11/32
60	186,964	1,558,033	43,125	.3594	23/64
65	202,544	1,687,869	46,719	.3893	25/64
70	218,125	1,817,706	50,312	.4193	27/64
75	233,705	1,947,542	53,906	.4492	29/64
80	249,285	2,077,376	57,500	.4792	31/64
85	264,866	2,207,214	61,093	.5091	1/2
90	280,446	2,337,050	64,687	.5390	17/32
95	296,026	2,466,886	68,281	.5690	9/16
100	311,607	2,596,722	71,875	.5989	19/32
105	327,187	2,726,558	75,468	.6289	5/8
110	342,767	2,856,395	79,062	.6589	21/32
115	358,348	2,986,231	82,656	.6888	11/16
120	373,928	3,116,067	86,250	.7187	23/32

24-FT. DIAMETER CYLINDER.
Circumference, 75.3982; area, 452.3893.

Height.	Capacity, Gallons.	Weight, Pounds.	Pressure, Pounds.	Thickness, Dec. In.	Thickness, Frac. In.
10	33,929	282,743	7,500		
15	50,894	424,115	11,250		
20	67,858	565,486	15,000		
25	84,823	706,858	18,750		
30	111,788	848,230	22,500	.1875	3/16
35	118,752	989,602	26,250	.2187	7/32
40	135,717	1,130,973	30,000	.2500	1/4
45	152,682	1,272,345	33,750	.2812	9/32
50	169,646	1,413,716	37,500	.3125	5/16
55	186,610	1,555,088	41,250	.3437	11/32
60	203,575	1,696,460	45,000	.3750	3/8
65	220,540	1,837,831	48,750	.4063	13/32
70	237,504	1,979,203	52,500	.4375	7/16
75	254,469	2,120,575	56,250	.4687	15/32
80	271,434	2,261,947	60,000	.5000	1/2
85	288,398	2,403,318	63,750	.5313	17/32
90	305,363	2,544,690	67,500	.5625	9/16
95	322,327	2,686,061	71,250	.5938	19/32
100	339,292	2,827,433	75,000	.6250	5/8
105	356,256	2,968,805	78,750	.6563	21/32
110	373,221	3,110,176	82,500	.6875	11/16
115	390,186	3,251,548	86,250	.7187	23/32
120	407,150	3,392,920	90,000	.7500	3/4

25-FT. DIAMETER CYLINDER.
Circumference, 78.5398; area, 490.8739.

10	36,815	306,796	7,812		
15	55,223	460,194	11,719		
20	73,631	613,592	15,625		
25	92,039	766,990	19,531		
30	110,447	920,389	23,437	.1871	3/16
35	128,854	1,073,787	27,344	.2279	15/64
40	147,262	1,227,185	31,250	.2604	17/64
45	165,670	1,380,583	35,156	.2929	19/64
50	184,077	1,533,981	39,062	.3255	21/64
55	202,485	1,687,379	42,969	.3581	23/64
60	220,893	1,840,777	46,875	.3906	25/64
65	239,301	1,994,175	50,781	.4232	27/64
70	257,709	2,147,573	54,687	.4558	29/64
75	276,117	2,300,971	58,594	.4883	31/64
80	294,524	2,454,370	62,500	.5208	17/32
85	312,932	2,607,768	66,406	.5534	9/16
90	331,340	2,761,166	70,312	.5859	19/32
95	349,748	2,914,563	74,219	.6185	5/8
100	368,155	3,067,962	78,125	.6510	21/32
105	386,563	3,221,360	82,031	.6836	11/16
110	404,971	3,374,758	85,937	.7161	23/32
115	423,379	3,528,156	89,844	.7487	3/4
120	441,786	3,681,554	93,750	.7812	25/32

CHAPTER V.

MECHANICAL PRINCIPLES.

IN the previous chapter it has been shown that the application of force as tension, compression, or shear, produces strain among the particles of which the body consists, and that this external pressure is resisted by the cohesive force of its fibres; also that the internal resistance of the particles depends upon their number and their arrangement in the cross-section. When weight or pressure is applied to such body as a beam or girder, two opposing forces are set in motion; one tending to cause rupture or the breaking of the beam through its cross-section, and the other exerting an opposing force of the fibre resistance depending in effect upon arrangement and tenacity. The tendency of the load applied to the beam is to produce "flexure" or bending, straining the fibres on the under side of the beam or producing tension among them, and compressing correspondingly the upper or outside fibres, both directly as their distance from the outer sides toward the centre of the beam. The strain which taxes to the maximum those most remote fibres from the central line, both by tension and compression, is gradually neutralized as the strain of tension and compression approach each other, and at the line of the cross-section where these two opposing forces meet, the fibres are at rest as regards each other, or are said to be in equilibrium, and at that line the fibres are neither under tension nor compression.

The line through the cross-section of any beam where the fibres are not strained is termed the "neutral axis" of the beam. In the case of all vertical loads, this neutral axis exists and passes through the centre of gravity of the beam cross-section parallel to the top and bottom faces of the beam.

Bending and Resisting Moments.—The effect of any vertical load, acting through the centre of gravity of the beam to produce flexure, is the amount of the load sustained and the point of application, or its leverage, as well the "bending moment" M at any cross-section of a beam, or the algebraic sum of the vertical forces on the left or right of the section, where the tendency of the forces is to cause motion by rotation around that point. The maximum bending moment occurs, of course, where the beam is most greatly strained. Without demonstration, the bending moment of a beam, uniformly loaded and supported at both ends, $M = \frac{1}{8}WL$; where W = the total load and l its leverage.

The resistance offered by the fibres and their arrangement to the effects of the applied load is determined by the "resisting moment," R , of the beam, and is found by obtaining the algebraic sum of all the moments of the horizontal stresses producing tension and compression of the fibres, acting in opposite directions but parallel to each other. These moments are determined, with respect to the neutral axis, by adding together or summing up algebraically all the moments of all the unit stresses acting upon all the elementary areas of which the cross-section consists.

When this value equals that of the applied weight when multiplied by its leverage of action, called the "moment of rupture," or M , we have the equation, $R = M$, indicating equilibrium between the forces tending to cause rupture and those which offer resistance to the former forces.

Moment of Inertia.—In the consideration and design of beams, the effect of the shape or cross-section of the beam has to be taken into account and is analyzed by the aid of a

quantity termed the "moment of inertia," I , which, referred to the neutral axis of the beam, is the product of the square of the distance from that axis to all the elementary areas of the cross-section, and its value is determined by summing up the product of the elementary areas, multiplied by the square of their distances from the neutral axis, or solving Σaz^2 where Σ represents the summation, a the elementary area, and z its distance from the neutral axis.

Without demonstration, the resisting moment, R , of a beam is determined by dividing the moment of inertia, I , by the distance, as c , from the neutral axis to the extreme fibres; therefore the formula, $R = \frac{I}{c}$.

Modulus of Elasticity.—As has been said, not only does the cross-section of the beam, representing the arrangement of the fibres, have to be taken into consideration in determining the resistance offered by a given form to an external force, but the tenacity of those fibres or their cohesive force, and this last consideration deals with the relative ability to resist "elastic deformation" to the point of "ultimate elongation" and rupture. Provided none of the stresses exceed the "elastic limit" of the material, the elongation and deflection of beams can be computed.

The letter E is generally taken to represent the "modulus of elasticity" or the "coefficient of elasticity," representative terms expressing the ratio of "unit stress" to "unit deformation," and to be found by dividing the unit stress, as S , representing say, the stress in pounds per square inch, by the unit of elongation which, by experiment, has been found to follow the application of stress on different materials, as s ; hence, $E = \frac{S}{s}$.

Under tension, and compression, experiment has determined that the coefficient or modulus E is practically the

same, while for shear stress, it is generally assumed at one-third less. It is further generally assumed that the stress under tension and compression when the elastic limit is reached is about six-tenths of the ultimate tenacity.

According to William Kent, A. M. M. E., one of the most recognized authorities on mechanical questions, the following are the

MODULI OF ELASTICITY FOR IRON AND STEEL.

Cast iron.....	12,000,000 to 27,000,000 (?)
Wrought iron...	22,000,000 to 29,000,000
Steel.....	26,000,000 to 32,000,000.

Quoting from "Kent's Pocket Book": "The maximum figures given by many writers for iron and steel, viz., 40,000,000 and 42,000,000, are undoubtedly erroneous. . . . The modulus of elasticity of steel (within the elastic limit) is remarkably constant, notwithstanding great variations in chemical analysis, temper, etc. It rarely is found below 28,000,000 or above 31,000,000. It is generally taken at 30,000,000 in engineering calculations."

The values given above are generally approximated as follows:

Cast iron.....	15,000,000	pounds	per	square	inch
Wrought iron..	25,000,000	"	"	"	"
Steel	30,000,000	"	"	"	"

When under tension or compression steel will stretch or shorten

$$\frac{l}{30,000,000}$$

part of its normal length for every pound per sectional inch in change of load.

The tendency of columns or struts under load is to fail by both compression and flexure, or bending, the column yield-

ing to the applied load, and deflecting laterally; the longer the column the greater the tendency to this lateral deflection or bending, and the greater the stresses upon the fibres of the concave side. The combined stress is very complex and difficult of demonstration, but it is pretty well established that the stress produced by such deflection increases directly as the *square* of the *length* of the beam.

In the discussion of columns, a quantity called the "radius of gyration" of the cross-section is an important factor in calculations, and, in the determination of the strength of a column or strut, represents the effect of the form of the column which is expressed by the square of the radius of gyration, or the moment of inertia of the section divided by its area, or $\frac{I - r^2}{A}$.

Radius of Gyration.—In the discussion of columns, a quantity called the "radius of gyration" is an important factor in the determination of the strength of columns to resist the applied stresses. This quantity has been defined as "that quantity whose square is equal to the moment of inertia of the cross-section divided by its area, or

$$r^2 = \frac{I}{A}$$

is the expression by which r^2 is to be computed.

"It should be observed that r has no connection with gyration, as I has no connection with inertia, in the case of sections of beams and columns.

"Radius of gyration is merely a technical name, which has unfortunately come into use, to denote the square root of the quantity $\frac{I}{A}$."

In the numerous publications by the larger steel manufactories, the radius of gyration, the moment of inertia, and the other elements of standard shapes have been conveniently tabulated

and are so generally accurate that it is seldom necessary to calculate these values from formulæ.

For the determination of the ultimate load of columns numerous formulæ have been developed, predicated upon, or modifications of, two original and well-known formulæ, those of Rankine and of Gordon. The following is

RANKINE'S FORMULA FOR COLUMNS.

$$\frac{P}{A} = \frac{S}{1 + \frac{ql^2}{r^2}}, \text{ where}$$

A = section area;

P = load on vertical column;

S = maximum unit stress;

r = radius of gyration;

l = length of column;

q = coefficient, depending upon kind of material and the arrangement of the ends. (Note. Where steel is used, and both ends fixed, $q = l \div 25,000$.)

The Gordon Formula for Strength of Columns.—Notwithstanding steel made into columns has shown a working value of 20% in excess of iron up to lengths of 90 radii of gyration, it is only recently that this allowance was made, some mills still retaining without modification the formula invented by Lewis Gordon in 1840, after tests made before the British Board of Trade, and which is as follows.

ULTIMATE STRENGTH OF COLUMNS.

$$\text{Square bearing} = \frac{40,000}{1 + \frac{(12l)^2}{36,000r^2}}.$$

For safe resistance: quiescent loads, as for a building, divide by 4.

For safe resistance: moving loads, as in bridges, divide by 5.

In the above formula, the constant, 12, is to reduce the length l , in feet, to inches; r represents the *least* radius of gyration. From Gordon's formula, the working value of the metal per square inch of section for columns of varying length is found; this, multiplied by the area of the section, gives the ultimate load.

To apply the Gordon formula, the length and section of the column must be known or assumed, and from the area of the cross-section the element r can be found by dividing the moment of inertia of the shape by its area, as has been shown; but in general r can be more conveniently found from any of the usual handbooks. In order to further lessen the computations, the following original table is given.

STRENGTH OF STEEL COLUMNS—BASED UPON GORDON'S FORMULA.

Factor of safety of 4 used in table. 20 per cent greater value assumed for steel than for iron columns.

l = length of column in feet.

r = least radius of gyration.

S = safe value of material per square inch of metal section.

$\frac{l}{r}$	S	$\frac{l}{r}$	S	$\frac{l}{r}$	S
2.0	11810	5.0	10908	8.0	9554
2.2	11774	5.2	10826	8.2	9456
2.4	11730	5.4	10746	8.4	9356
2.6	11683	5.6	10662	8.6	9260
2.8	11635	5.8	10578	8.8	9162
3.0	11586	6.0	10490	9.0	9062
3.2	11582	6.2	10400	9.2	8964
3.4	11468	6.4	10310	9.4	8864
3.6	11408	6.6	10218	9.6	8768
3.8	11346	6.8	10124	9.8	8670
4.0	11276	7.0	10032	10.0	8570
4.2	11208	7.2	9938	10.2	8474
4.4	11136	7.4	9842	10.4	8376
4.6	11060	7.6	9746	10.8	8180

The table is based upon the Gordon formula for iron columns with a higher value of 20 per cent, which from experiment has

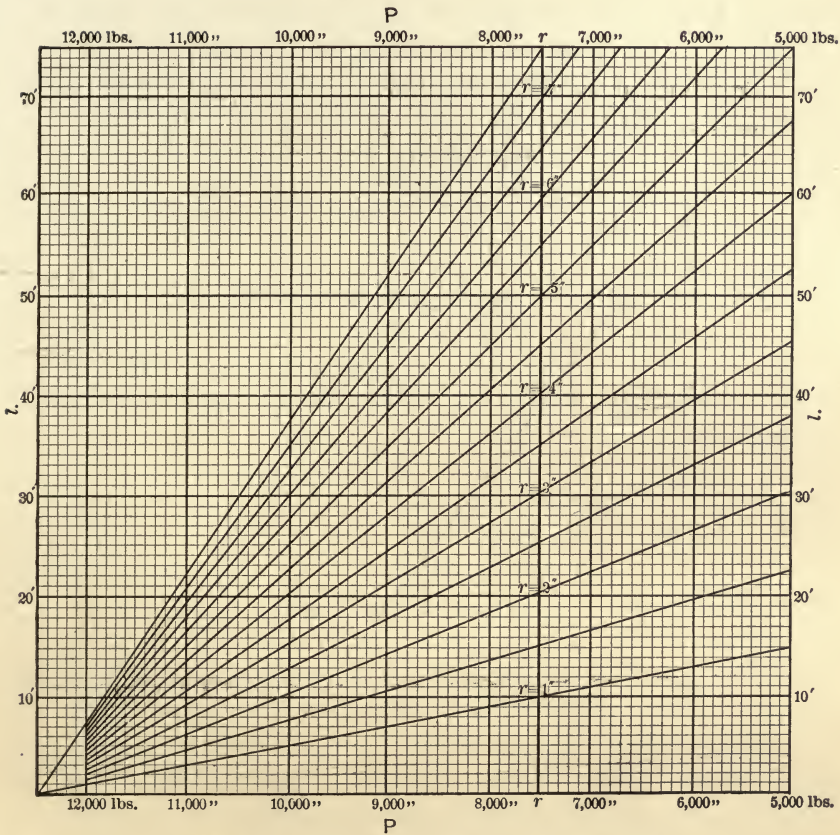

DIAGRAM OF STRAIGHT-LINE COMPRESSION FORMULAS.

Formula: $P = 12,500 - 500(l \div r)$,
 P = compression in pounds per square inch,
 l = unsupported length of member in feet,
 r = radius of gyration in inches.

Explanation. Find the required r on the line $r - r$, then follow the diagonal which crosses at that point, until it crosses the line representing the required l (read at the sides of the diagram). The vertical line through this intersection represents P (read at the top and bottom of diagram). Diagonal lines representing r are drawn at each half-inch only. Lines for intermediate values may be drawn in, or a ruler or thread used to indicate them.

been determined as applicable to steel columns less than 90 radii.

To use the table, divide the length of the column in feet by the *least* radius of gyration of the section, and from the corresponding ratio of the table find the unit strength of the material in pounds, which, multiplied by the combined area of the shape, will give the safe load in pounds for a column of the required length and cross-section.

Of late numerous straight-line compression formulas have been presented, and diagrams constructed from same have sprung into common use. Herewith is reproduced one prepared by Mr. O. W. Childs, C.E., and published in January, 1900, by the *Engineering News*.

CHAPTER VI.

THE STRESSES IN A STEEL WATER-TOWER.*

It is the purpose of this chapter to collect and reduce to convenient working form the formulæ required in solving the stresses in a steel water-tower. A water-tower is understood to be a water-tank and the tower or trestle supporting it. The tower may have three or more posts. It is assumed that the posts are spaced equidistant, i.e., at the corners of a regular polygon. The tank is cylindrical. Its bottom may be flat, conical, or spherical. The flat bottom is rarely used in important structures and will not be considered.

The forces acting on a water-tower are gravity and wind pressure. These forces or loads must be transmitted by the structure from the points of application to the points of support or foundations. In the discussion following, the loads will be traced from their points of application to the foundations, and the resulting stresses in the successive members or parts of the structure determined. Secondary stresses, i.e., local stresses resulting from details of construction, will not be considered.

GRAVITY STRESSES.

The force of gravity acting on a water-tower equals the weight of the structure plus the weight of the water supported by it. The weight of the proposed water-tower may be deter-

* By H. J. Burt. Revised from paper in *The Technograph*, No. 16, 1901-2, University of Illinois.

mined, accurately enough for purposes of design, by comparison with the design of a similar structure, if such is available

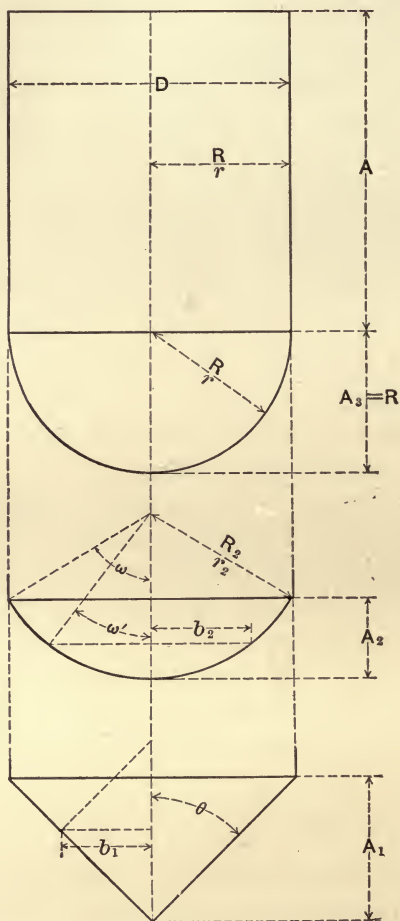

FIG. 18.

or from the tentative designs of the several parts as the weights of those parts are required. The weight of the water can be de-

terminated readily from the cubical contents of the tank, using the following values:

1 cubic foot of water weighs	62.5 pounds
1 gallon of water weighs	8.33 pounds
1 cubic foot contains	7.48 gallons

This weight is correct within one-half of one per cent. and errs on the side of safety.

Nomenclature.—Fig. 18 illustrates the nomenclature of dimensions used in the formulæ.

H equals the depth or head of water in feet at the point under consideration.

p equals the hydrostatic pressure in pounds per square inch, hence equals $0.434H$.

W equals the total load in pounds supported by the section or member under consideration.

Dimensions in feet are expressed by capital letters, and in inches by small letters.

Capacity of Cylinder.

$$\text{Capacity in cubic feet} = \frac{\pi D^2 A}{4}.$$

$$\text{Capacity in gallons} = \frac{\pi D^2 A}{4} \times 7.48 = 5\frac{1}{2} D^2 A.$$

$$\text{Capacity in pounds} = \frac{\pi D^2 A}{4} \times 62.5 = 49.1 D^2 A.$$

For practical purposes it is accurate enough to use $50D^2A$ for the last expression, the error being less than 2%, and on the side of safety.

Capacity of Cone.

$$\text{Capacity in cubic feet} = \frac{\pi D^2 A_1}{12} = 0.262 D^2 A_1.$$

$$\text{Capacity in gallons} = \frac{\pi D^2 A_1}{12} \times 7.48 = 1.96 D^2 A_1.$$

$$\text{Capacity in pounds} = \frac{\pi D^2 A_1}{12} \times 62.5 = 16.36 D^2 A_1.$$

Capacity of Segment of a Sphere.

$$\begin{aligned} \text{Capacity in cubic feet} &= \frac{1}{3} \pi R_2^3 (2 - 3 \cos \omega + \cos^3 \omega), \\ &\text{or } \frac{1}{3} \pi A_2^2 (3R_2 - A_2). \end{aligned}$$

$$\begin{aligned} \text{Capacity in gallons} &= 7.84 R_2^3 (2 - 3 \cos \omega + \cos^3 \omega), \\ &\text{or } 7.84 A_2^2 (3R_2 - A_2). \end{aligned}$$

$$\begin{aligned} \text{Capacity in pounds} &= 65.5 R_2^3 (2 - 3 \cos \omega + \cos^3 \omega), \\ &\text{or } 65.5 A_2^2 (3R_2 - A_2). \end{aligned}$$

Capacity of Hemisphere.—The hemisphere may be considered a special case of the segment of a sphere in which $A_2 = R_2 = \frac{D}{2}$, and $\omega = 90^\circ$; then

$$\text{Capacity in cubic feet} = \frac{\pi D^3}{12} = 0.262 D^3.$$

$$\text{Capacity in gallons} = 1.96 D^3.$$

$$\text{Capacity in pounds} = 16.36 D^3.$$

Areas of Surfaces.—The areas of the surfaces are needed for computing the weight of metal in the shell. They are:

$$\text{Cylinder. area in square feet} = \pi D A.$$

$$\text{Cone. area in square feet} = \frac{1}{2} \pi D A_1 \sec \theta.$$

$$\text{Segment. area in square feet} = \pi \left(\frac{D^2}{4} + A_2^2 \right), \text{ or } 2\pi R_2 A_2.$$

$$\text{Hemisphere, area in square feet} = \frac{1}{2} \pi D^2.$$

Stresses in the Cylinder.—The stress on a *horizontal joint* of a vertical cylinder, or on the section made by a horizontal plane,

mm (Fig. 19), is compression. Its amount equals the weight of the portion of the structure above the plane in question. Ordinarily this is the weight of the tank plates and roof. In cold climates it may be increased by ice adhering to the tank. There is no appreciable direct stress on a horizontal joint resulting from hydrostatic pressure. The compression per lineal inch of circumference of the joint is $\frac{W}{2\pi r}$, in which W is the weight in pounds supported on the whole circumference and r is the radius in inches.

The stress on a *vertical joint* of the cylinder is produced by the hydrostatic pressure on the inside of the cylinder. This pres-

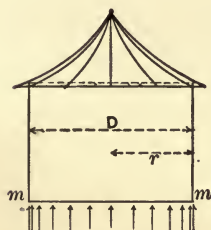

FIG. 19.

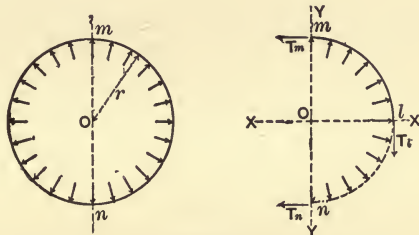

FIG. 20.

sure is normal to the surface, therefore radial, and its intensity in pounds per square inch of surface is $p=0.434H$. Assume a ring one inch in height cut from the cylinder at a depth of H feet from the top. The internal pressure will then be p pounds per lineal inch of the ring (Fig. 20).

Pass a diametral plane mn cutting the ring at m and n , and consider the half to the right of mn . To maintain equilibrium of the half-ring the forces T_m and T_n must act at m and n respectively. Then T_m and T_n equal the tension in the shell at m and n . By symmetry $T_m = T_n$.

By mechanics * it can be shown that $T_m = T_n = \frac{1}{2} \Sigma X$ components of the radial pressures = pr .

Since the diametral plane can be in any position, the tension is the same at all points on the circumference of the ring.

Taking n as a centre of moments,

$$M_n = 2pr \times r - T_m \times 2r = 0,$$

hence there is no bending moment in the shell.

Consider now a quarter-ring ml .

$$T_l = T_m,$$

$$T_l - \Sigma Y \text{ components of } p = 0,$$

$$T_m - \Sigma X \text{ components of } p = 0;$$

therefore there is no horizontal shear at m or at l .

Thus it is shown that the stress on a vertical joint is tension only, and the amount per lineal inch of joint is $T = pr = 0.434Hr$, where T is the tension in pounds per lineal inch of the joint. Note that if p acts inward instead of outward we have compression instead of tension.

Stresses in the Cone.—To find the stress on a *circumferential* joint or on the section cut by a horizontal plane (Fig. 21), let ee be such a section. The load, W , on the cone eej is the weight of the cylinder of water whose base is ee and whose height is the distance from ee to the top of the tank, plus the weight of water in the cone eej , plus the weight of steel in the cone eej . This load must be supported by the forces T acting along the elements of the cone and around the perimeter of ee . Then $\Sigma T = W \sec \theta$.

The forces T equal the tension on the joint. This tension is uniformly distributed on the perimeter of ee . Hence the

* For proof see page ; also "Stresses in Tank Bottom," by Prof. A. N. Talbot, in *The Technograph*, No. 16, page 137.

tension per lineal inch of joint is $T = \frac{W \sec \theta}{2\pi b_1}$, where b_1 is the radius of the section in inches.

The value of T varies from 0 at j to a maximum at g . It also varies from 0 when $\theta = 0^\circ$ (cylinder) to infinity when $\theta = 90^\circ$

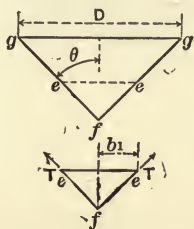

FIG. 21.

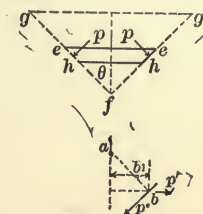

FIG. 22.

(plane), i.e., the flatter the cone the greater the stress on the circumferential seams.

To find the stress on a *radial joint* pass two horizontal planes through the cone at such distances apart that the intercept eh along the elements of the cone equals one inch (Fig. 22). Then the surface $ehhe$ cut from the cone is a tapered ring. This ring is subjected to a normal pressure of p pounds per lineal inch. For p substitute its components p' and p'' which are horizontal and along the elements of the cone respectively.

$$p' = p \sec \theta,$$

$$p'' = p \tan \theta.$$

By reasoning similar to that used in determining the stress on a vertical joint of the cylinder it may be shown that the horizontal component p' produces tension in the ring. Let T be the tension per lineal inch of the radial joint, then $T = p'b_1 = pb_1 \sec \theta$, where b_1 is the radius of the ring in inches. $b_1 \sec \theta$ is represented graphically by the line \overline{ab} , hence $T = p \times \overline{ab}$.

The value of T varies from 0 at j to a maximum at g .

The component p'' together with the similar components acting on the elements between h and j produce tension on the horizontal joint through e , the amount of which has already been determined.

Stresses in the Segment of a Sphere.—The stress on a *circumferential joint* of the segment of a sphere is determined by analysis similar to that used for the cone (Fig. 23). The tension on one lineal inch of the joint ee is

$$T = \frac{W \csc \omega'}{2\pi b_2},$$

in which W is the weight supported by the segment eje , and b_2 is the radius of the section. Let r_2 be the radius of the sphere, then

$$b_2 = r_2 \sin \omega',$$

and

$$T = \frac{W \csc^2 \omega'}{2\pi r_2}.$$

The tension per lineal inch on any *meridian*, or *radial joint* of a sphere subjected to an internal normal pressure of p pounds per square inch is $T = \frac{pr_2}{2}$. From this it is inferred that the tension per lineal inch at any point e of a radial joint of a segmental bottom is $T = \frac{pr_2}{2}$, p being the normal pressure per square inch at e .*

When the bottom is a hemisphere $r_2 = r$, then $T = \frac{pr}{2}$.

The value of T varies with the pressure, p , and hence is a maximum at the bottom of the segment.

* See "Stresses in Tank Bottoms," by Professor Arthur N. Talbot, *The Technograph*, No. 16, page 138.

Stresses in the Joint Between the Bottom and the Cylinder.

—The vertical load, W , on this joint equals the total weight of water in the tank plus the weight of the tank bottom, and is

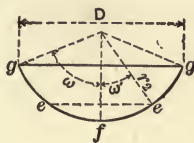

FIG. 23.

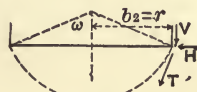
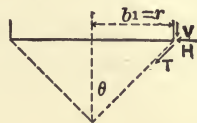

FIG. 24.

transmitted thereto by the plates forming the bottom. The tension per lineal inch in these bottom plates at this joint is determined from the formula

$$T = \frac{W \sec \theta}{2\pi b_1}$$

for the cone (Fig. 21) and

$$T = \frac{W \csc \omega'}{2\pi b_2}$$

for the segment of the sphere (Fig. 23). At this joint b_1 and b_2 equal r , and the above formulas become respectively

$$T = \frac{W \sec \theta}{2\pi r}$$

and

$$T = \frac{W \csc \omega}{2\pi r}$$

This tension in the bottom plates will be treated as the load on the joint.

When the tank bottom is *conical* (Fig. 24) the load T on the joint is applied along the elements of the cone. To provide for its resistance it must be resolved into its horizontal and vertical components H and V .

$$H = T \sin \theta = \frac{W \sec \theta}{2\pi r} \times \sin \theta = \frac{W \tan \theta}{2\pi r},$$

$$V = T \cos \theta = \frac{W \sec \theta}{2\pi r} \times \cos \theta = \frac{W}{2\pi r}.$$

The horizontal component is a uniform radial force amounting to $\frac{W \tan \theta}{2\pi r}$ pounds per lineal inch of perimeter pulling toward the axis of the cylinder. This produces compression in the ring of material constituting the joint. Using this normal pressure and considering the ring cut by a vertical plane, it will be seen that the total compression on a section of the ring is

$$C = \frac{W \tan \theta}{2\pi r} \times r = 0.159 W \tan \theta.$$

The vertical component V is resisted by the circular girder. Its analysis will be considered hereinafter.

Considering the *segmental bottom* (Fig. 24) in a similar manner,

$$H = T \cos \omega = \frac{W \csc \omega}{2\pi r} \times \cos \omega = \frac{W \cot \omega}{2\pi r};$$

$$V = T \sin \omega = \frac{W \csc \omega}{2\pi r} \times \sin \omega = \frac{W}{2\pi r};$$

$$C = 0.159 W \cot \omega.$$

When $\omega = 90^\circ$ the bottom is a hemisphere and H and C become 0.

It is this that makes the hemisphere the most desirable form of bottom.

It will be noted that the value of V is independent of the shape of the bottom.

The above analysis assumes that the joint is theoretically perfect, that is, that the lines of action of H , V , and T intersect in a common point. In the case of both the conical and the segmental bottoms the plates have to be flanged so as to become tangent to the cylinder. Thus the element of the cone and the element of the cylinder must be connected by a curve, likewise the meridian element of the segment and the element of the cylinder (Fig. 25). This connecting curve may be part of a sphere

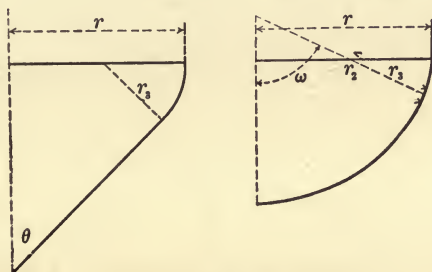

FIG. 25.

or part of an ellipsoid of revolution. In the former case r_3 equals r , and in the latter case r_3 is less (or greater) than r .

The stresses in this connecting part of the bottom are complex. An analysis of them is given by Professor Talbot,* from

which it seems that when the ratio of $\frac{r}{r_3} = 2$, $H = 0$ and there is no resulting tension or compression on the joint-ring; when $\frac{r}{r_3} < 2$ there is tension; and when $\frac{r}{r_3} > 2$ there is compression.

* See "Stresses in Tank Bottoms," by Professor Arthur N. Talbot, *The Technograph*, No. 16, page 139.

As it is easier in construction to provide for the tension, it seems advisable to make the value of $\frac{r}{r_3}$ or < 2 . When the bottom is a hemisphere $\frac{r}{r_3} = 1$, that is, $r = r_3$.

If r_3 is made very small in comparison with r , there are undoubtedly bending stresses in the plate. The amount of these stresses cannot be determined readily, consequently they should be avoided.

It will generally be most satisfactory to use the hemispherical bottom, as all stresses will then be determinate. Such bottoms can now be manufactured without undue expense.

Stresses in the Circular Girder.—The circular girder sustains the vertical component just determined plus the weight of the steel cylinder, the tank roof, and its own weight. That is, it

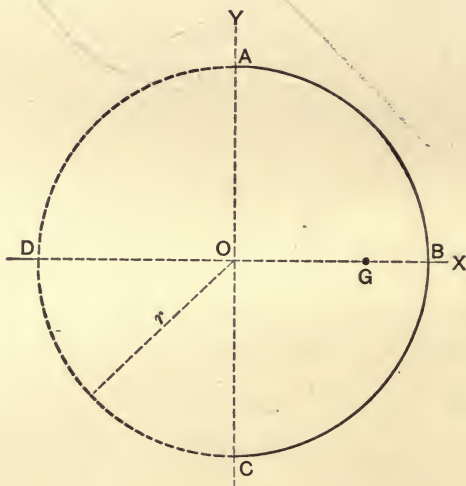

FIG. 26.

supports the whole weight of the tank, the contents of the tank, and itself. This load is uniformly distributed along the girder.

The girder rests on the tops of the tower posts, and transmits the load to them. There may be four or more posts or points of support.

Consider first a girder with four points of support.* Let W be the total load, and let $A, B, C,$ and D be the points of support of the circular girder (Fig. 26). By symmetry the reactions $R_A, R_B, R_C,$ and R_D are equal to each other, hence each is $R = \frac{W}{4}$. Assume the axes of reference $X, Y,$ and Z passing through $O,$ the axis of Z being vertical. Consider the left half of the girder cut away by a plane just to the left of the points of support A and C . The forces required to maintain the equilibrium of the right half equal the stresses in the girder at A and C . The possible forces at A are

- a horizontal force parallel to $X = +S_x$;
- a horizontal force parallel to $Y = +S_y$;
- a vertical force parallel to $Z = +S_z$;
- a couple perpendicular to $X,$ whose moment $= +M_x$;
- a couple perpendicular to $Y,$ whose moment $= +M_y$;
- a couple perpendicular to $Z,$ whose moment $= +M_z$;

and at C the possible forces are

$$\begin{array}{lll}
 +S_x, & -S_y, & \text{and } +S_z; \\
 -M_x, & +M_y, & \text{and } -M_z.
 \end{array}$$

The external forces acting on the portion of the girder considered are $\frac{W}{2}, R_A, R_B,$ and R_C . These external forces have no components parallel to $X,$ hence

$$\begin{array}{ll}
 & S_x = 0. \\
 \text{Likewise} & S_y = 0.
 \end{array}$$

* Adapted from "The Bending Moment in a Circular Girder," by G. P. Starkweather, *Engineering News*, Nov. 15, 1900.

From the summation of the Z components,

$$2S_z + \frac{W}{2} - (R_A + R_B + R_C) = 0;$$

$$2S_z + \frac{W}{2} - 3\left(\frac{W}{4}\right) = 0;$$

$$S_z = \frac{W}{8},$$

which is the vertical shear in the girder at the sections to the left of A and C .

Let G be the centre of gravity of the load on the half-girder. The distance OG is $\frac{2r}{\pi}$, in which r is the radius of the girder.

For determining moments the load on the half-girder, $\frac{W}{2}$, will be considered as acting at G .

M_x and M_z are indeterminate from the conditions given, but from other considerations it can be shown that

$$M_x = 0$$

and

$$M_z = 0.$$

M_y is determinate.

$$2M_y + \left(\frac{W}{2} + \frac{2r}{\pi}\right) - \left(\frac{W}{4} + r\right) = 0,$$

$$M_y = \frac{Wr}{2} \left(\frac{1}{4} - \frac{1}{\pi}\right)$$

$$= 0.03415Wr,$$

which is the bending moment in the girder at A and at C .

To determine the stresses at any point between supports, consider the arc AP , A being a point of support and P an intermediate point at which the stresses are required. Assume the axes of X' , Y' , Z' through P . Let α be the angle AOP expressed in circular measure, then the load on AP is

$$\frac{W\alpha}{2\pi}.$$

The centre of gravity of the load is at G .

The geometric relations of the figure are (Fig. 27)

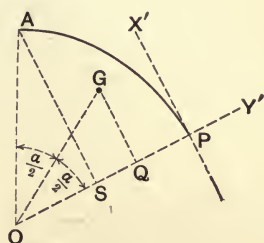

FIG. 27.

$$\overline{OG} = \frac{2r \sin \frac{\alpha}{2}}{\alpha};$$

$$\overline{OQ} = \frac{2r \sin \frac{\alpha}{2} \cos \frac{\alpha}{2}}{\alpha} = \frac{r \sin \alpha}{\alpha};$$

$$\overline{QP} = r - \frac{r \sin \alpha}{\alpha} = \frac{r}{\alpha}(\alpha - \sin \alpha);$$

$$\overline{QG} = \frac{2r \sin^2 \frac{\alpha}{2}}{\alpha} = \frac{r}{\alpha}(1 - \cos \alpha);$$

$$\overline{AS} = r \sin \alpha;$$

$$\overline{SP} = r(1 - \cos \alpha).$$

The known forces acting on AP are the vertical shear $S_z = \frac{W}{8}$ on the left of A , the reaction R_A , the couple at A whose moment is $M_y = \frac{Wr}{2} \left(\frac{1}{4} - \frac{1}{\pi} \right)$, and the load $\frac{W\alpha}{2\pi}$.

The unknown forces are those required at P to maintain equilibrium and equal the stresses in the girder at P . The possible forces at P are

- a horizontal force parallel to $X' = +S'_x$;
- a horizontal force parallel to $Y' = +S'_y$;
- a vertical force parallel to $Z' = +S'_z$;
- a couple perpendicular to X' whose moment $= M'_x$;
- a couple perpendicular to Y' whose moment $= M'_y$;
- a couple perpendicular to Z' whose moment $= M'_z$.

By summation of components,

$$S'_x = 0;$$

$$S'_y = 0;$$

$$S'_z = R_A - S_z - \frac{W\alpha}{2\pi}$$

$$= \frac{W}{4} - \frac{W}{8} - \frac{W\alpha}{2\pi} = \frac{W}{2} \left(\frac{1}{4} - \frac{\alpha}{\pi} \right).$$

S'_z is a maximum when $\alpha = 0$; then

$$S'_z = S_z = \frac{W}{8};$$

when $\alpha = \frac{\pi}{4}$,

$$S'_z = 0;$$

that is, the point of zero shear is midway between supports.

Since the only horizontal forces acting are couples in vertical planes,

$$M'_z = 0.$$

The moment at P about the axis of X' is a torsional moment,

$$\begin{aligned} M'_x &= M_y \sin \alpha - \frac{W\alpha}{2\pi} \overline{QP} + \frac{W}{8} \overline{SP} \\ &= \frac{Wr}{2} \left(\frac{1}{4} - \frac{1}{\pi} \right) \sin \alpha - \frac{Wr}{2\pi} (\alpha - \sin \alpha) + \frac{Wr}{8} (1 - \cos \alpha) \\ &= \frac{Wr}{8} (1 + \sin \alpha - \cos \alpha) - \frac{Wr\alpha}{2\pi}. \end{aligned}$$

$M'_x = 0$ when $\alpha = 0$ and when $\alpha = \frac{\pi}{4}$, i.e., there is no torsional moment at the point of support nor midway between supports. To determine the place of maximum value of M'_x ,

$$\frac{dM'_x}{d\alpha} = \frac{Wr}{8} (\cos \alpha + \sin \alpha) - \frac{Wr}{2\pi} = 0.$$

$$\cos \alpha + \sin \alpha = \frac{4}{\pi} = 1.2732,$$

$$\alpha = 19^\circ 12' \text{ or } 70^\circ 48',$$

and the maximum values are

$M'_x = -0.0053Wr$ when $\alpha = 19^\circ 12' = 0.3351$ radians,
and $M'_x = +0.0053Wr$ when $\alpha = 70^\circ 48' = 1.2356$ radians.

The moment at P about the axis of Y' is the bending moment in the girder at P . It is

$$\begin{aligned} M'_y &= M_y \cos \alpha - \frac{W\alpha}{2\pi} \overline{QG} + \frac{W}{8} \overline{AS} \\ &= \frac{Wr}{2} \left(\frac{1}{4} - \frac{1}{\pi} \right) \cos \alpha - \frac{W\alpha r}{2\pi} (1 - \cos \alpha) + \frac{W}{8} r \sin \alpha \end{aligned}$$

$$= \frac{Wr}{8} (\sin \alpha + \cos \alpha) - \frac{Wr}{2\pi}.$$

When $\alpha = 0$,

$$M'_y = \frac{Wr}{2} \left(\frac{1}{4} - \frac{1}{\pi} \right) = -0.03415Wr,$$

which is the bending moment in the girder over the point of support.

When $\alpha = \frac{\pi}{4}$,

$$M'_y = \frac{Wr}{2} \left(1.4142 - \frac{1}{\pi} \right) = +0.01762Wr,$$

which is the bending moment in the girder midway between supports.

Between the values of $\alpha = 0$ and $\alpha = \frac{\pi}{4}$ there must be a value of α that will make

$$M'_y = \frac{Wr}{8} (\sin \alpha + \cos \alpha) - \frac{Wr}{2\pi} = 0,$$

from which

$$\sin \alpha + \cos \alpha = 1.2732,$$

and

$$\alpha = 19^\circ 12' \text{ or } 70^\circ 48'.$$

A comparison of the values obtained for M'_x and M'_y shows the following important results

1. The points of maximum torsion moment are points of zero bending moment.

2. The points of maximum bending moment are points of zero torsion moment.

Considering now girders having a number of points of support other than four, we can make analyses similar to the foregoing. Their results for several cases, including the results

just obtained for the four points of support, are summarized in the following table:

STRESSES IN THE CIRCULAR GIRDER.

No. of Points of Support.	Reaction at Point of Support.	Max. Shear.	Bending Moment over Point of Support.	Bending Moment midway between Supports.	Angular Distance Point of Support to Point of Maximum Torsion.	Maximum Torsional Moment.
	Pounds.	Pounds.	Inch-pounds.	Inch-pounds.		Inch-pounds.
4.	$\frac{W}{4}$	$\frac{W}{8}$	$-0.03415Wr$	$+0.01762Wr$	$19^\circ 12'$	$0.0053Wr$
6.	$\frac{W}{6}$	$\frac{W}{12}$	$-0.01482Wr$	$+0.00751Wr$	$12^\circ 44'$	$0.00151Wr$
8.	$\frac{W}{8}$	$\frac{W}{16}$	$-0.00827Wr$	$+0.00416Wr$	$9^\circ 33'$	$0.00063Wr$
12.	$\frac{W}{12}$	$\frac{W}{24}$	$-0.00365Wr$	$+0.00190Wr$	$6^\circ 21'$	$0.000185Wr$

In the above table W is the total weight supported by the girder in pounds, and r is the radius of the girder in inches.

Stresses in the Posts.—It was shown in the consideration of the circular girder that the vertical load on the top of a post is the total weight of the circular girder, the tank and its contents divided by the number of posts. In addition to this load the posts of each story must carry the weight of posts, struts, and ateral rods of the stories above it. Thus the vertical load on any one section or story of the post is readily determined. Let the vertical load on the section under consideration be W . If the post is vertical, the compression in it equals W . If the post is inclined, the compression becomes

$$C = W \sec \phi, \quad (\text{Fig. 28,})$$

ϕ being the angle of inclination of the post from the vertical. The vertical reaction at the base of the post equals W . To maintain equilibrium there

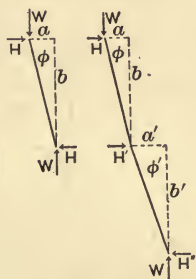

FIG. 28.

must be a horizontal reaction H at the top and at the bottom of the post, in the same vertical plane as the post, i.e., in a diametral plane.

$$H = W \tan \phi.$$

If the inclination is expressed in rectangular co-ordinates,

$$H = W \frac{a}{b}$$

and

$$C = W \frac{\sqrt{a^2 + b^2}}{b}.$$

When there is a change in the inclination of the post there must be a horizontal reaction in a diametral plane at the point of change. Let H' be this reaction. Then

$$\begin{aligned} H' &= H'' - H \\ &= W \tan \phi' - W \tan \phi, \end{aligned}$$

or

$$H' = W \left(\frac{a'}{b'} - \frac{a}{b} \right).$$

Stresses Resulting from the Horizontal Thrust at the Top of the Posts.—At the top of each post there is a radial inward

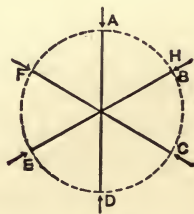

FIG. 29.

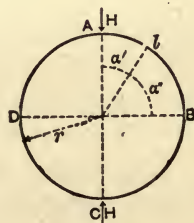

FIG. 30.

thrust whose value has been determined from the vertical load and inclination of the post. Let H be the amount of this thrust.

When struts between diagonally opposite posts are used to resist this thrust the compression in each strut equals H . (Fig. 29.)

If struts are not used, the radial forces may be resisted by the bottom flange of the circular girder. Since the width of the girder flange is small compared with the radius of the girder, the solution of the stresses in a circular hoop may be applied.

When a pair of radial forces H act on a hoop, as at A and C (Fig. 30), the stresses at any point l resulting therefrom are:*

$$\text{Bending moment, } M' = Hr \left(\frac{\sin \alpha'}{2} - \frac{1}{\pi} \right).$$

$$\text{Shear, } S' = \frac{H}{2} \cos \alpha'.$$

$$\text{Compression, } C' = \frac{H}{2} \sin \alpha'.$$

A second pair of forces H acting at B and D produce stresses at l :

$$M'' = Hr \left(\frac{\sin \alpha''}{2} - \frac{1}{\pi} \right);$$

$$S'' = \frac{H}{2} \cos \alpha'';$$

$$C'' = \frac{H}{2} \sin \alpha''.$$

Then the stresses at l resulting from both pairs of forces are the algebraic sums of the partial stresses. The general equations for these stresses when the forces are in equal pairs are

* Transactions Association of Civil Engineers, Cornell University, 1896.

$$M = \frac{Hr}{2} [\sin \alpha' + \sin \alpha'' + \dots \sin \alpha^n] - \frac{nHr}{\pi},$$

$$S = \frac{H}{2} [\cos \alpha' + \cos \alpha'' + \dots \cos \alpha^n],$$

$$C = \frac{H}{2} [\sin \alpha' + \sin \alpha'' + \dots \sin \alpha^n],$$

n being the number of pairs. $2n$ equals the number of forces acting, i.e., the number of posts supporting the circular girder.

From the above general equations the following table of stresses results:

STRESSES IN RING AT TOP OF POSTS.

Number of Posts.	Bending Moment.		Shear.		Compression.	
	Under Load.	Midway between Loads.	Under Load.	Midway between Loads.	Under Load.	Midway between Loads.
	Inch-pounds.	Inch-pounds.	Pounds.	Pounds.	Pounds.	Pounds.
4.....	$-0.137Hr$	$+0.0705Hr$	$0.50H$	0.00	$0.50H$	$0.707H$
6.....	$-0.089Hr$	$+0.045Hr$	$0.50H$	0.00	$0.87H$	$1.00H$
8.....	$-0.067Hr$	$+0.033Hr$	$0.50H$	0.00	$1.21H$	$1.31H$
12.....	$-0.044Hr$	$+0.022Hr$	$0.50H$	0.00	$1.87H$	$1.93H$

In the above table H is the horizontal thrust in pounds at the top of each post, and r is the radius of the ring in inches.

This radius is approximately equal to the radius of the tank cylinder.

In many cases the ring formed by the bottom flange of the circular girder is not sufficient to resist the stresses resulting from the thrust at the top of the posts, without using a large amount of metal in the ring. This will be the case in large structures when the posts have considerable inclination. In such a

case a continuous curved girder in the horizontal plane may be used (Fig. 31).

The stresses in this horizontal girder can be determined by treating it as an arch without hinges. Assume the girder to be cut in two equal parts by the plane mm . Then the half-girder

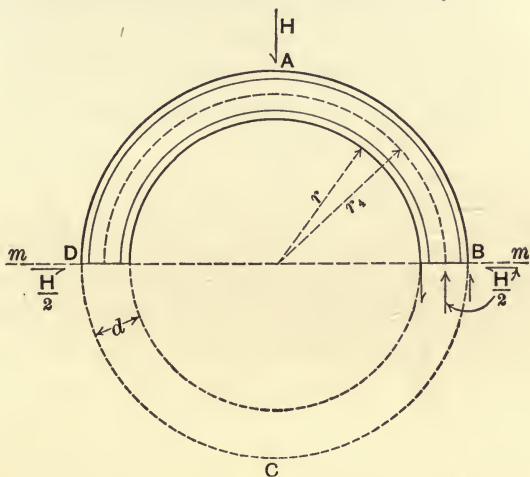

FIG. 31.

ABD will form a semicircular arch, sustaining a load of H pounds at the crown and a thrust of $\frac{H}{2}$ pounds at each abutment. At each abutment there is also a couple whose moment must be determined in order to find the stresses in the girder. The bending moment at the abutment and the resulting bending moments at the other points in the arch may be determined by the methods usually employed in the analysis of the elastic arch. Graphical analyses of the stresses in horizontal curved girders having four, six, eight, and twelve loaded points, or points of support, give coefficients varying not more than three per cent. from those given in the table of Stresses in Ring at Top of Posts (page 130). Strict mathematical analysis would probably give identical results. In any case, the variation is so small

that the table just referred to can be used for determining the stresses in a horizontal curved girder.

In using this table for determining the stresses in a horizontal curved girder, the value of H to be used is the horizontal thrust in pounds at the top of each post, and the value of r to be used is r_4 , as shown in Fig. 31, i.e., the radius of the neutral axis of the girder in inches. The value of r_4 is approximately r , the radius of the tank in inches, plus $\frac{1}{2}d$, d being the width of the girder in inches. This approximate value is sufficiently accurate for determining stresses.

The flange stress in the girder resulting from the bending moment can be determined by dividing the bending moment by the depth, d , centre to centre of flanges in inches. To this flange stress must be added algebraically the compression at the point under consideration. It is proper to consider that the compression is resisted by the flanges of the girder and divided equally between them. As in ordinary plate-girder design, the shear may be considered to be resisted by the web plate.

If a lattice girder is used instead of a plate girder, the bending moment at the abutments of the arch may be replaced by a couple whose lever-arm is the depth of the girder centre to centre of flanges. From these reactions and the loads the stresses in the members of the lattice girder may be determined by graphical methods.

Horizontal Stresses at Plane of Change of Inclination of Posts.—The amount of the horizontal thrust at each post at the point of change of inclination has been determined. Let H' represent this thrust (Fig. 32). Then if the thrust is resisted by struts between diagonally opposite posts, as AD , the compression in each strut equals H' . If the thrust is resisted by struts between adjacent posts, as AB , the compression in each strut equals

$$\frac{H'}{2} \sec \beta.$$

Horizontal Stresses at the Base of the Tower.—The amount of the horizontal thrust at the foot of each post has been determined. This thrust may be resisted by direct shear

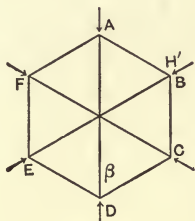

FIG. 32.

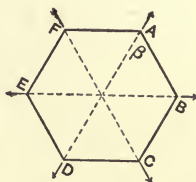

FIG. 33.

on the anchor-bolts, or by the friction of the shoe on the masonry, or by both. When thus resisted the thrust produces an overturning moment on the foundation (Fig. 33).

Or ties may be used between adjacent posts. Then the stress in each tie is $\frac{H}{2} \sec \beta$, and there is no overturning moment on the foundation.

WIND STRESSES.

The intensity of wind pressure depends on the area of the surface exposed and the velocity of the wind. The relation between these two quantities is not known, but in general it can be said that the larger the area the less the intensity, and the greater the velocity the greater the intensity. The action of a wind current is probably analogous to the action of a stream of water. Obstructions produce cross-currents and eddies, making the pressure on a given unit area of the exposed surface variable. The shape of the exposed surface doubtless influences the intensity. Water-towers are usually placed in exposed positions. Their importance makes it advisable that they be designed to withstand the greatest wind pressure that is

likely to occur. Since wind stresses do not control the design of the heavier parts of the structure, there is but little excess material used if the assumed wind pressure is greater than the actual wind pressure. The writer considers it good practice to design water-towers to withstand a wind pressure of 30 pounds per square foot of projected area of the tank and the members of the tower.

Stresses in the Cylinder.—Under the assumption made above, the forces acting on the cylinder will be as shown in the diagram (Fig. 34). The cylinder may be treated as a cantilever beam. Then the bending moment at the fixed end in inch-pounds is

$$M = 30AD \times \frac{1}{2}A \times 12 = 180A^2D.$$

The extreme fibre stress resulting is determined from the formula

$$S = \frac{Mr}{I}$$

in which S is the extreme fibre stress per square inch, M is the bending moment just determined, r is the distance in inches of the extreme fibre from the centre, which in this case is the radius of the cylinder, and I is the moment of inertia. The moment of inertia of a thin cylinder about a diameter is

$$I = \pi r^3 t,$$

t being the thickness of the shell. Then

$$S = \frac{180A^2D \times r}{\pi r^3 t} = 9.55 \frac{A^2}{rt}.$$

In water-towers of usual dimensions this stress is small, but in stand-pipes and chimneys it may become large. The local bending stresses are indeterminate.

The wind stresses in the tank bottom and in the circular girder cannot be definitely determined. They are probably small in comparison with the gravity stresses.

Stresses in the Tower.—The wind loads acting on the tower are the loads transmitted to it by the tank and the direct wind pressure on the members of the tower. The former are applied at the tops of the posts, and the latter will be considered as concentrated at the panel points.

Consider the tank a rigid body, then the reactions at the top of the posts due to the wind pressure on the tank will be a

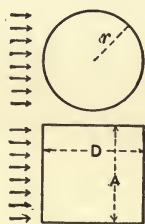

FIG. 34.

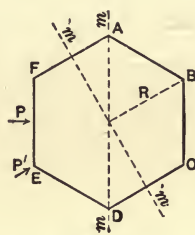

FIG. 35.

set of horizontal forces and a set of vertical forces. Let P be the total wind pressure on the tank, including the roof.

This may be considered as acting at the center of gravity of the projected area. (The center of pressure on the conical bottom is at $\frac{1}{3}$ the depth, and on the hemispherical bottom at a depth of $\frac{4r}{3\pi}$. The pagoda roof may be reduced to an approximately equivalent cone for the purpose of this computation.) Let G be the distance in feet from the tops of the posts to the centre of gravity, then the overturning moment in foot-pounds is

$$M = PG.$$

This overturning moment must be resisted by the connections of the tank to the posts.

The distribution of the vertical forces among the posts is uncertain. To determine it, the position of the axis about which the tank tends to rotate must be known. This depends on the rigidity of the connections, which cannot be determined readily. When the connections give the same resistance to tension as to compression the axis of rotation passes through the centre of the polygon. This condition obtains when the posts are riveted directly to the tank cylinder. When the resistance to tension is very small compared to the resistance to compression the axis of rotation is near the extreme leeward post (or posts). This condition obtains when the circular girder rests on top of the posts and is bolted thereto. The former condition gives a maximum tension on the windward side, and the latter a maximum compression on the leeward side. As the connections of the tank to the post should be rigid, approximating the former condition, that case only will be considered.

Assume the direction of the wind normal to the side EF and the axis of rotation mm (Fig. 35). Since the stress in each post is proportional to its distance from the axis of rotation mm , the tension $V_E = V_F = -V_B = -V_C$, and there is no stress at A and D . Taking moments about mm , the moment equation is

$$M = 4V_E \times 0.866R,$$

$$V_E = \frac{M}{3.464R} = 0.29 \frac{M}{R},$$

in which M is the overturning moment previously determined.

Next assume the wind in the direction of a diagonal EB and the axis of rotation $m'-m'$. Then

$$V_F = V_D = -V_A = -V_C = \frac{1}{2}V_E = -\frac{1}{2}V_B,$$

$$M - (V_A + V_C + V_D + V_F)0.5R + (V_B + V_E)R = 0,$$

$$V_E = \frac{M}{3R} = 0.33 \frac{M}{R},$$

$$V_F = 0.167 \frac{M}{R}.$$

Thus it appears that the maximum vertical load due to wind pressure, at the top of any post, results when the wind is assumed in the direction of the diagonal passing through that post.

The stress in each post resulting from a given direction of the wind can be determined readily from the above relations. The method of analysis is applicable to a tower having any number of posts.

The vertical load (either tension or compression) at the top of a post being determined, the stress in the post is the product of the vertical load and the secant of the angle of inclination as shown under gravity stresses, and, as in the case of gravity stresses, there is a horizontal component at the top of the post. As these horizontal components at the tops of the several posts are not in equilibrium, they must be transmitted through the tower to the foundations.

Considering the case in the adjoining figure (Fig. 36), these horizontal components are about as represented by the arrows marked c , the dotted arrow, P , indicating the direction of the wind. The value of each must be determined from the vertical load on its post resulting from the assumed direction of the wind. The horizontal components will be combined with the direct horizontal shears at the tops of the posts and the resulting stresses in the tower determined.

The set of horizontal forces previously referred to consists of the direct shears at the tops of the posts. It will be assumed that the tank, circular girder, and horizontal curved girder are capable of distributing the shear equally among the posts, and that the segments of the girders from post to post are capable of acting as struts of the tower bracing. Then the shear at each

post is $\frac{P}{n}$, acting in a line parallel to the direction of the wind. These shears are represented by the arrows marked *s*.

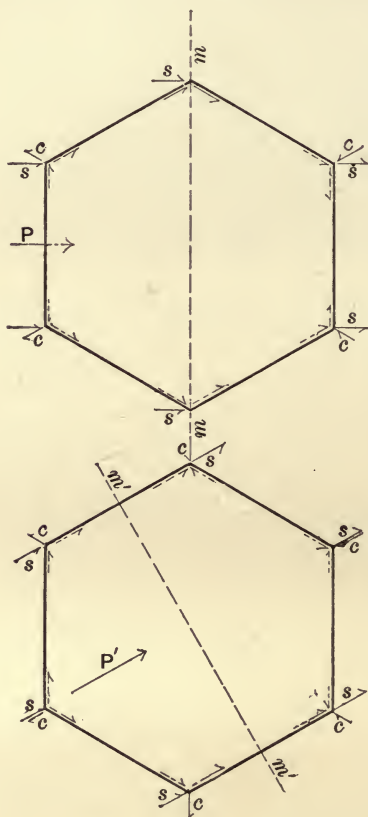

FIG. 36.

These horizontal loads, *c* and *s*, are transmitted to the foundations by the tower frame. To determine the stresses resulting, the loads must be resolved into their components lying in the planes of the sides of the tower. These components are shown by the dotted arrows (Fig. 36). In like manner the panel loads

at the successive panel points are resolved into the planes of the sides of the tower.

Considering the side of the tower $FAA'F'$, the loads acting thereon are as indicated (Fig. 37). The framing forms a cantilever truss anchored at F' and A' . The reactions resulting from the loads on this cantilever can be computed readily from the dimensions of the structure by the method of moments and shears (Σ Moments = 0, Σ Horizontal Comp. = 0, and Σ Vert. Comp. = 0). Having determined the loads and reactions, the stresses in the truss members can be solved by graphical analysis. Each post is common to two adjacent trusses of the tower, and its total stress is the algebraic sum of its stresses resulting from its membership in the two trusses.

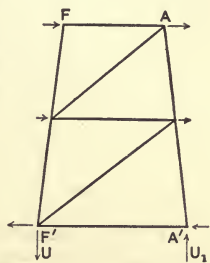

FIG. 37.

An inspection of the components of the shear at the top of the tower (Fig. 36) will show in which sides of the tower the maximum stresses occur for the assumed direction of the wind, but the concurrent stresses in the adjacent sides or trusses must be solved in order to determine the total stresses in posts.

If the inclination of the sides of the tower changes at each story, each story must be analyzed separately. The anti-reactions at the base of one story become the loads at the top of the next lower story.

Loads on the Foundations.—The reactions U and U_1 at F' and A' in the above figure (Fig. 37) lie in the plane of the side of the tower (i.e., the plane of the truss under consideration). This plane being inclined ρ° , the loads on the foundation resulting are a vertical component,

$$U \cos \rho^\circ, \text{ or } U_1 \cos \rho^\circ,$$

and a horizontal component,

$$U \sin \rho^\circ, \text{ or } U_1 \sin \rho^\circ.$$

(Do not confuse ϕ , the inclination of the posts, and ρ , the inclinations of the sides.)

Each foundation is common to two trusses, and the loads from the two must be combined algebraically. And in addition to these there is the direct load resulting from the vertical load at the top of the post.

The total vertical load due to wind pressure on any foundation, as at A , is the sum of the vertical component of the direct stress in the post, the vertical component of the reaction U of the truss AB , and the vertical component of the reaction U_1 of the truss AF , due attention being given to the signs.

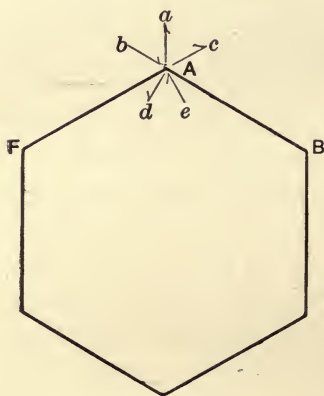

FIG. 38.

The horizontal load due to wind pressure (Fig. 38) on any foundation, as at A , is the resultant of the horizontal component (radial) of the direct stress in the post (a), the horizontal shear from the truss AB (b), the horizontal shear from the truss AF (c), the horizontal component of the reaction U of the truss AB (d), and the horizontal component of the reaction U_1 of the truss AF (e).

If the bottoms of the posts are connected by struts (ties), the resultant horizontal load on each foundation equals s (Fig. 36), and its line of action is parallel to the direction of the wind.

CONCLUSION.

The possible conditions of loading for a water-tower are:

1. Weight of structure.
2. Weight of structure and weight of water.
3. Weight of structure and wind pressure.

4. Weight of structure, weight of water, and wind pressure.

Each part of the structure must be designed to resist the maximum stress that can result from any combination of the above. Generally loading No. 2 governs the design of the tank, circular girder and horizontal curved girder; No. 3, the anchorage, the tension connections of tank to posts, and the bracing of the tower; and No. 4, the posts and foundations.

The assumptions made in the analysis for wind stresses are believed to be reasonable and on the side of safety. When there are several alternative assumptions that one should be used which gives maximum results for the member under consideration. The wind stresses in the tank shell and the circular girder are indefinite, but it is believed that they are small compared with the gravity stresses in these members, and can be neglected.

In some cases the stresses in certain members are so small that they need not be considered in designing. However, it is not safe to neglect them in the general discussion, since in structures of unusual proportions they might be important.

CHAPTER VII.

RIVETING.

IN structural metal-work, the usual method of uniting "plates" or of connecting "shapes" is by riveting.

The riveted joint is technically termed a "lap-joint" when one plate overlaps the other. It is a "butt-joint" when the two plates are brought together, their edges in contact, and the plates fastened by the use of a cover-strip or "welt," which overlaps both plates; when two such cover-strips are used, the one on the outside and the other on the inside of the two plates in contact, the joint is termed a "double-welt butt-joint."

Such joints are further distinguished as being "single-riveted" when a single row of rivets is used as fasteners for the two plates. It is a "double-riveted joint" when two rows of rivets are used; so, also, "triple-riveted" and "quadruple-riveted" when three and four rows respectively are used as fasteners; thus, a "triple-riveted, double-welt butt-joint" is one where three rows of rivets are used in making a joint between two plates, covered inside and out with covering-strips or "welts."

In the correspondence columns of the *Engineering News*, Mr. Freeman C. Coffin, M. Am. Soc. C. E., in discussing "Specifications for Stand-pipes," and referring to the character of joint, suggests some points where there is room for improvement. He writes as follows: "One is the method of

joining the plates. The present method of lapping both horizontal and vertical seams is awkward and unmechanical, and belongs more to the methods of the village blacksmith than those of precise and scientific mechanism. They should rather be like the accompanying sketch, taken from a paper read before the New England Water-works Association in 1893.

“In this sketch the horizontal seams are lapped, and the vertical seams made with butt-straps. This is a perfectly pre-

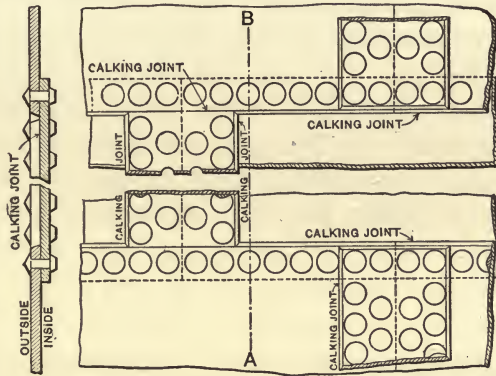

FIG. 39.—METHOD OF JOINING PLATES IN STEEL.

cise method, and requires no beating down or drawing out of the plates, and, in my opinion, would really cost no more than the old way. I use it now on plates over $\frac{1}{2}$ in. in thickness, but should prefer to use it on all thicknesses.”

Notwithstanding Mr. Coffin's opinion as to the relative cost, builders of stand-pipes will make quite a difference in the cost of a particular structure if the butt-joint is required, as it seems perfectly proper that they should do, for the reason that a butt-joint requires twice as many rivets as a lap-joint, because in the lap the rivet passes through both the plates, whereas in the butt-joint it passes through only one, so that there is necessarily an additional cost for punching or drilling, rivets, and driving.

There is no question, however, as to the increased value of a joint made as suggested by Mr. Coffin over the usual method, and it would seem as though the best practice should govern where the whole strength of the structure may depend upon its method of being assembled.

Efficiency of Riveted Joints.—The “efficiency” of a riveted joint is described as being the ratio of the strength of the joint to that of the *solid plate*. Thus, a joint is said to have a 70-per-cent. efficiency when the loss of strength, as compared with its ultimate strength, is 30 per cent.

In order to determine the efficiency of a riveted joint, it is necessary to know or to assume the following conditions:

(1) The tensile strength of the plate. (2) The diameter of the rivets used. (3) The unit resistance of these rivets, and their “pitch” or spacing, taken from centre to centre.

When proper values have been determined for the foregoing conditions, it has been found by practical tests and demonstrations that the efficiency of the several joints is approximately as follows:

Single-riveted joint.....	56	per cent. eff.
Double- “ “	69	“ “ “
Triple- “ “	75	“ “ “
Double-welt butt-joint.....	87	“ “ “
Quadruple-riveted butt-joint..	95	“ “ “

One of the most interesting and practical discussions of the theory and practice of riveting with which the author is familiar, is contained in an address delivered to the students of Cornell College by Mr. J. M. Allen, president of the Hartford Steam Boiler and Insurance Co., and from which is quoted the following:

Single-riveted Joints (Fig. 40).—“In calculating the strength of a single-riveted joint we must know, *first*, what the tensile strength of the iron or steel plate is, from tensile

test; *second*, the diameter and pitch of the rivets; and *third*, the resistance to shearing per square inch of the material of which the rivets are made. On this latter requirement there has been no little discussion. It was formerly assumed, when only iron plates and iron rivets were used, that the shearing-resistance of a square inch of rivet was equal to the tensile strength of a square inch of the rivet itself or of the plate. That is, if we have iron of a tensile strength of 45,000 lbs. per square inch, the shearing-resistance of a square inch of rivet would be 45,000 lbs. On this assumption it would be only necessary to so arrange the diameter and pitch of rivets that

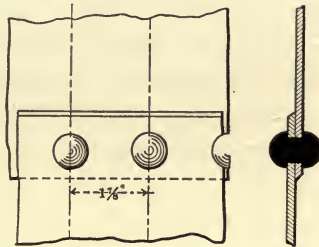

FIG. 40.—SINGLE-RIVETED JOINT.

the area of the rivet or rivets to be sheared should exactly equal the net section of plate to secure a perfect joint. Later experiments, together with the improvements in the manufacture of iron, and the introduction of steel, have changed these conditions relatively. While the shearing-resistance of the rivets per square inch has been, and even to-day is, by many assumed to be 45,000 lbs. per square inch, the assumption has arisen, no doubt, from the fact that rivets rarely shear. I have examined many exploded boilers, and the fractures have almost invariably been through the solid plate or along the line of rivets. It is very rare that the rivets shear. This, no doubt, arises from the fact that the pitch of the rivets was out of proportion to the net section of the plate. The old rule seemed to be: the more rivets, the stronger joint. There was, no doubt, a desire on the part of the boiler-makers to

make a tight joint, and they thought that if they pitched the rivets wider it would be difficult to caulk the joint so that it would be steam- and water-tight.

One would quite naturally assume that steel plates should be riveted with steel rivets, but such is not the usual practice. Most of the boilers now constructed in this country are made of steel plates, and they are largely riveted with iron rivets. In this country there have been comparatively few experiments on the strength of riveted joints made of steel plates and steel rivets, and as the general practice is to use iron rivets with both iron and steel plates, I confine myself here to the discussion of the iron rivet. I will say, however, that in England very careful experiments have been made, and a large percentage of strength is given to steel rivets over iron rivets. When the true value of the steel rivet is fully decided, and its use becomes general in this country, that value can be easily substituted for the value of iron rivets in the calculations of the strength of riveted joints, the other elements of the problem remaining the same.

What value, then, shall we give to the iron rivets when used in connection with steel or iron plates? In settling this question, I have not only been aided by the experiments of English engineers, but I have availed myself of experiments made on the large Emery testing-machine at the U. S. Arsenal at Watertown, Mass. These experiments have been made with American iron and steel, and hence will be valuable to us all in our practical work in this country. In a series of five experiments with steel plates and iron rivets, holes punched, the shearing-resistance per square inch was as follows: 39,740 lbs., 38,190 lbs., 36,770 lbs., 38,638 lbs., and 41,100 lbs. In view of these results, and other similar experiments, I assume 38,000 lbs. per square inch as the safe estimate of the single shearing-resistance of iron rivets in steel plates. Later experiments may change these figures

slightly. In these experiments the steel plate was 55,000 lbs. tensile strength per sq. in.

Assuming 38,000 lbs. as the safe estimate, we must decide upon the thickness of plate, diameter of rivet-hole, and pitch of rivets. In deciding upon these elements in the problem, we must so adjust the size and pitch of rivets as to make the shearing-resistance of the rivets as near the strength of net section as possible. I will assume the elements of the problem to be as follows:

Steel plate, tensile strength per square inch of section, 55,000 lbs.

Thickness of plate $\frac{5}{16}$ in. = decimal 0.3125.

Diameter of rivet-hole $\frac{1}{4}$ in. = decimal 0.8125.

Area of rivet-hole = decimal 0.5185.

Pitch of rivets $1\frac{7}{8}$ ins. = decimal 1.875.

Shearing-resistance of iron rivets per square inch = 38,000 lbs.

Then $1.875 \times 0.3125 \times 55,000 = 32,226$ lbs. = strength of solid plate.

$(1.875 - 0.8125) \times 0.3125 \times 55,000 = 18,262$ = strength net section of plate.

$0.5185 \times 38,000 = 19,703$ lbs. = strength one rivet in single shear.

Net section of plate is the weakest, therefore $18,262 \div 32,226 = 56.6$ per cent. efficiency of joint.

Double-riveted Joints (Fig. 41).—In double-riveted joints we find an accession of strength over single-riveted joints of nearly 20 per cent. This arises from the wider lap and the better distribution of the material. The rivets are pitched wider, and there is more rivet-area to be sheared, together with a larger percentage of net section of plate to be broken.

Steel plate, tensile strength per square inch of section, 55,000 lbs.

Thickness of plate $\frac{3}{8}$ in. = decimal 0.375.

Diameter rivet-hole $\frac{1}{8}$ in. = decimal 0.9375.

Area of rivet-hole = decimal 0.69.

Pitch of rivets $3\frac{1}{8}$ ins. = decimal 3.0625.

Shearing-resistance of iron rivets per square inch, 38,000 lbs.

Then $3.0625 \times 0.375 \times 55,000 = 63,164 =$ strength of solid plate.

$(3.0625 - 0.9375) \times 0.375 \times 55,000 = 43,828$ lbs. = strength of net section.

$0.69 \times 2 \times 38,000 = 52,440$ lbs. = strength of two rivets in single shear.

Net section of plate is the weakest, therefore $43,828 \div 63,164 = 69.3$ per cent. efficiency of joint.

70 per cent. is usually assumed in practice.

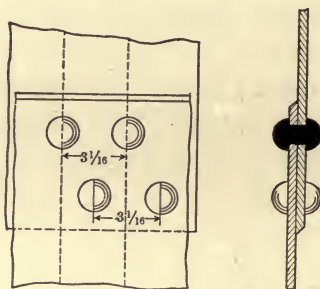

FIG 41.—DOUBLE-RIVETED JOINT.

Triple-riveted Joint (Fig. 42).—In a triple lap-riveted joint we still gain in strength for reasons similar to those above.

Steel plate, tensile strength per square inch of section, 55,000 lbs.

Thickness of plate $\frac{3}{8}$ in. = decimal 0.375.

Diameter of rivet-holes $\frac{1}{8}$ in. = decimal 0.8125.

Area of rivet-hole = decimal 0.5185.

Pitch of rivets $3\frac{1}{4}$ ins. = decimal, 3.25.

Shearing-resistance of iron rivets per square inch, 38,000 lbs.

Then $3.25 \times 0.375 \times 55,000 = 57,031$ lbs. = strength of solid plate.

$(3.25 - 0.8125) \times 0.375 \times 55,000 = 50,273$ lbs. = strength of net section plate.

$0.5185 \times 3 \times 38,000 = 59,109$ lbs. = strength of 3 rivets in single shear.

Net section of plate is weakest, therefore $50,273 \div 67,031 = 75$ per cent. efficiency of joint.

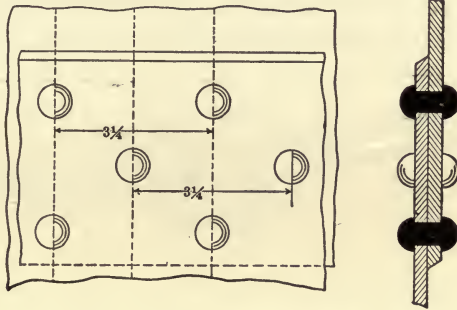

FIG. 42.—TRIPLE-RIVETED JOINT.

Double-welt Butt-joint (Fig. 44).—We now come to the double-welt butt-joint, triple-riveted.

I have selected this joint because we use it in practice where boilers of large diameters and high pressures are required.

In the double-welt joint a new element comes into the problem, viz., that of rivets in double-shear. Its inner welt is broader than the outer welt, and extends far enough beyond the former to enable us to introduce a third row of rivets, which are in single-shear, but also are in double-pitch. This increases the net section of plate, and also adds another rivet to be sheared. All the other rivets are in double-shear. The question now arises, What is the value of a rivet in double-shear? We have assumed, therefore, that the value of a rivet in single-shear was 38,000 lbs. per square inch.

Now, can we assume that the same rivet in double-shear has twice the value that it had in single-shear? It has been

assumed by some writers that such is the case, and up to this time most engineers allow a double value to rivets in double-shear. In the former the rivet is sustained by the plates above and below, while in single-shear the resistance is confined to one point.

An examination of the sheared sections of rivets in single-shear usually discloses a slight elongation in the direction of the force applied. The experiments on rivets in single-shear, and from which we get our data, have almost always been made on single-riveted joints, with narrow strips of iron, as shown in Fig. 43.

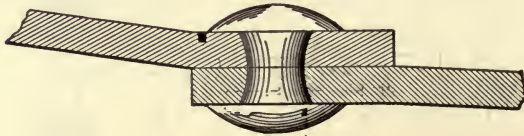

FIG. 43.

And it is reasonable to assume that there is a slight tendency in the rivet to lean in the direction of the force applied, which would account for the slight elongation of the sheared section in that direction. An examination of the sheared sections of rivets in double-shear shows little or no elongation. The rivets being supported by the plates above and below, the shear is direct, and the section is normal in form. Experiments made by the English Admiralty with $\frac{3}{4}$ -inch rivets showed that the double-shear was about 90 per cent. stronger than the same diameter of rivet in single-shear. Chief Engineer Shock, U.S.N., found by experiment that the resistance of bolts of iron to single-shear was 40,700 lbs. per square inch, and in double-shear 75,300 lbs. This gives an increase of strength of 85 per cent. The results of numerous experiments, both in this country and in Europe, show the resistance to double-shear to be from 85 to 90 per cent. greater than the same rivets in single-shear. From the foregoing I assume 85 per cent. as a fair and safe estimate of

the excess of strength of rivets in double-shear over those in single-shear. We have already assumed that the resistance of rivets per square inch to single-shear is 38,000 lbs. If we add to this 85 per cent., we shall have 70,300 lbs. as the safe estimate of the resistance of iron rivets per square inch to double-shear. Further experiments may change these figures slightly, but I regard them as safe for use in all places where joints riveted with iron rivets are used. The use of the double-welt butt-joint in the construction of boilers is becoming quite common. This arises from the use of boilers of much larger diameter than those formerly used, and also the necessity for higher pressures on account of the introduction of compound engines.

With larger diameter and higher pressures, we find ourselves confronted with a very important problem. We must keep within the bounds of safety, for these large vessels are very destructive to life and property if we disregard the importance of good material, good workmanship, and the well-established factors of safety. It is not always safe to assume the highest results obtained by experimental tests. There will always be those who will insist upon higher pressures than safe rules will allow. Hence it becomes important that the consulting engineer shall thoroughly understand the principles of safe construction, and not allow himself to be moved in his judgment where the question of safety is involved. We will now apply the above data to the following problem :

Steel plate, tensile strength per sq. in. of section, 55,000 lbs.

Thickness of plate $\frac{3}{8}$ in. = decimal 0.375.

Diameter of rivet-holes $1\frac{3}{8}$ in. = decimal 0.8125.

Area of rivet-hole = decimal 0.5185.

Pitch of rivets in inner rows $3\frac{1}{4}$ ins. = decimal 3.25.

Pitch of rivets in outer rows $6\frac{1}{2}$ ins. = decimal 6.50.

Resistance of rivets in single-shear = 38,000 lbs.

Resistance of rivets in double-shear = 70,300 lbs.

$6.5 \times 0.375 \times 55,000 = 134,062$ lbs. = strength of solid plate.

$(6.5 - 0.8125) \times 0.375 \times 55,000 = 117,304$ lbs. = strength of net section of plate at *AB*.

$0.5185 \times 4 \times 70,300 = 145,802$ lbs. = strength of 4 rivets in double-shear.

$0.5185 \times 38,000 = 19,703$ lbs. = strength of 1 rivet in single-shear.

This last result must be added to the strength of four rivets in double shear—thus, $145,802 + 19,703 = 165,505$ = shearing-strength of all the rivets. The net section of plate

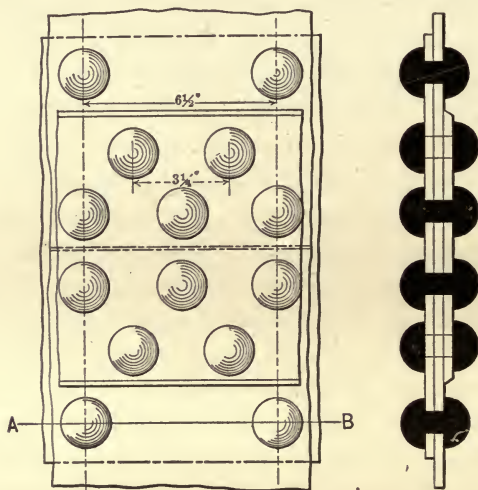

FIG. 44.—DOUBLE-WELT BUTT-JOINT.

is weakest; therefore, $117,304 \div 134,062 = 87.5$ per cent. efficiency of joint.

It will no doubt be observed that the strength of rivets in this joint is largely in excess of the strength of net section of plate, and the question will arise, Why increase the width of the inner covering-strip and add two more rivets? As stated above, this was done to increase the net section of plate at *AB*,

and thus increase the efficiency of the joint. If the inner welt or covering-strip had been of the same width as the outer one, the net section of the plate would have been greatly reduced, and the difference of strength between net section of plates and rivets would have been greater, thus reducing the efficiency of joint. The problem would be as follows:

$$6.5 \times 0.375 \times 55,000 = 134,062 = \text{strength of solid plate.}$$

$$(6.5 - 0.8125 \times 2) \times 0.375 \times 55,000 = 100,546 = \text{strength of net section of plate.}$$

$0.5185 \times 4 \times 70,300 = 145,802 = \text{strength of 4 rivets in double shear.}$ Net section of plate is the weakest; therefore, $100,546 \div 134,062 = \text{only 75 per cent. efficiency of joint.}$

Again, it may be suggested: Why not dispense with one row of rivets in double shear, and extend the inner welt or covering-strip so that the outer row of rivets in double pitch and single shear could be used, thus increasing net section of plate as in the original problem, but reducing at the same time the shearing-resistance of the rivets?

The solution of this problem would be as follows:

$$6.5 \times 0.375 \times 55,000 = 134,062 = \text{strength of solid plate.}$$

$$(6.5 - 0.8125) \times 0.475 \times 55,000 = 117,304 = \text{strength of net section.}$$

$$0.5185 \times 2 \times 70,300 = 72,901 = \text{strength of 2 rivets in double shear.}$$

$$0.5185 \times 38,000 = 19,703 = \text{strength of 1 rivet in single shear.}$$

This last result must be added to the result of 2 rivets in double shear. $72,901 + 19,703 = 92,604 = \text{strength of all the rivets.}$

The total strength of the rivets is the weakest; therefore, $92,604 \div 134,062 = 69 \text{ per cent. efficiency of joint.}$

It may be further suggested that a rivet of smaller diameter could be used. I will say that I have also considered such

a problem, but have come to the conclusion that the joint, as illustrated and described, for efficiency and freedom from leaks, is best. I will say here that a joint of this description was carefully made and tested on the Emery machine at the United States Arsenal at Watertown, Mass. The result of the test was two-twentieths of 1 per cent. of the calculation made, and the line of fracture was through the net section of plate at the outer row of rivets, as we had predicted."

Since the lecture delivered by Mr. Allen, in 1891, there has been rapid progress both in the manufacture and use of steel for structural purposes, and the practice of uniting steel plates with steel rivets has become the rule rather than the exception, although it seems that the great majority of metal-workers continue to be very conservative in assuming higher shearing-values for steel rivets, and while the steel rivet is used, calculations are made upon its efficiency without assuming much higher values than it has been the practice to give to iron rivets subject to shear.

In 1896 the United States Government made a series of tests upon riveted joints at the Watertown Arsenal. These experiments were made on joints formed of steel plate, and both iron and steel rivets.

An investigation of the reports shows the average shearing-value of steel rivets to have run as high as 55,000 lbs. per square inch for rivets of $\frac{3}{4}$ -in. and $\frac{7}{8}$ -in. diameters, and about 45,000 lbs. for steel bolts under the same conditions.

From these tests it would seem that the shearing-value of rivets in single-shear was about the same as the ultimate strength of steel rods under tension; and it would therefore seem that a higher working value for rivets might be established, and that for rivets in single-shear an ultimate value of 45,000 to 50,000 lbs. per square inch of metal would not be radical or likely to prove unsafe.

As has been shown, if the plate and rivet be given the same values, it would only be necessary to so arrange the diameter and pitch of rivet that the area of the rivets should equal that of the net section of plate to secure a perfect joint, but the ultimate value of plate steel is about 60,000 lbs., and that of rivet metal 50,000 lbs. per sq. in., and practice has further increased the difference between the metals by allowing only about 40,000 lbs. ultimate strength to rivet-rods under shear.

The area of the rivet-hole represents the true section of the rivet when driven, and therefore the area of the rivet-hole, multiplied by the shearing-value of the metal, gives the strength of the rivet.

The pitch of the rivet, representing a section of plate, multiplied by its thickness and the tensile strength of the metal, gives the strength of the solid plate, while the pitch of the rivet, or length of section, less one-half the diameter of the rivet-hole at *each* end of the section, or for both ends, the diameter of the rivet-hole, multiplied by the thickness of the plate and its ultimate tensile strength, will give the strength of the *net* section of plate. The relation of these values expressing the "efficiency" of the joint in per cent. is therefore found by dividing the greater value by the least.

Pitch of Rivets.—The pitch of the rivet is found by the formula

$$P = \frac{A \times S}{T \times Q} + D, \text{ where}$$

P = Pitch of rivet,

A = Area of rivet-hole in decimal of an inch,

S = Shearing-value of rivet,

T = Thickness of plate,

Q = Tensile strength of plate,

D = Diameter of rivet-hole in inches.

Where rivet is in more than single pitch, multiply by number of rivets in row.

Example.—Find the proper pitch for double-riveted joint, $\frac{1}{4}$ in. plate and $\frac{5}{8}$ -in. rivet :

$$P = \frac{3712 \times 2 \times 40,000}{.2500 \times 60,000} + .6875 = 2.6671 \text{ or } 2\frac{5}{8} \text{ in.}$$

In the example above, 40,000 lbs. is taken as being a conservative value for a rivet in single-shear, and as allowing some latitude for irregularity in shop-work.

Size of Rivets in Relation to Thickness of Plates.—The determination of the size of rivet to be used as a fastener for certain thicknesses of plates is not governed by any hard and fast rule, but varies considerably in the practice of different manufacturers.

From investigation made by the United States Government, the relation of thickness of plates to diameter and length of rivets has been established by the Bureau of Construction and Repair, Navy Department, as follows:

Thickness of Plate, Inches.	Diam. of Rivet.		Corresponding Rivet-hole Area.			Length, Inches.
	In.	Dec.	In.	Dec.		
Less than $\frac{3}{16}$	$\frac{3}{16}$.3750	$\frac{7}{16}$.4375	.1503	$\frac{7}{8}$
$\frac{3}{16}$ to $\frac{1}{4}$	$\frac{1}{2}$.5000	$\frac{9}{16}$.5625	.2485	1
$\frac{1}{4}$ " $\frac{5}{16}$	$\frac{5}{8}$.6250	$\frac{11}{16}$.6875	.3712	$1\frac{1}{4}$
$\frac{5}{16}$ " $\frac{3}{8}$	$\frac{3}{4}$.7500	$\frac{13}{16}$.8125	.5185	$1\frac{3}{4}$
$\frac{3}{8}$ " $\frac{7}{8}$	$\frac{7}{8}$.8750	$\frac{15}{16}$.9375	.6903	$2\frac{1}{4}$
$\frac{1}{2}$ " 1.....	1	1.0000	$1\frac{1}{8}$	1.6250	1.0031	$2\frac{7}{8}$

[NOTE.—Centres of rivets are spaced not less than $1\frac{1}{2}$ times their diameter from the edges. In double- and treble-riveting, their distance from centre to centre of rows (horizontal pitch) to be not less than $2\frac{1}{2}$ diameters in laps, and $2\frac{1}{2}$ diameters for straps.]

In the above table the length includes length of shank necessary to form the field-head measured under manufacturers' head, and for a "grip" equal to twice the thickness of plate assumed.

In order to facilitate calculations for water-tight metallic joints, the following table, providing an efficiency of joint suitable for metallic reservoirs, and an auxiliary diagram of details, has been designed by the author.

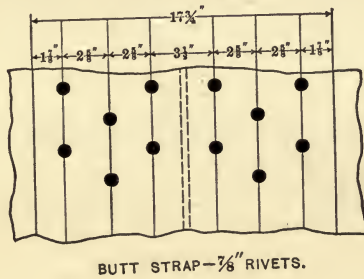
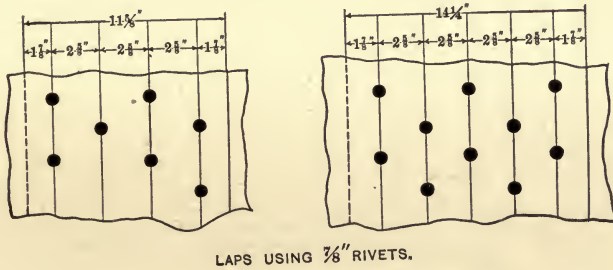
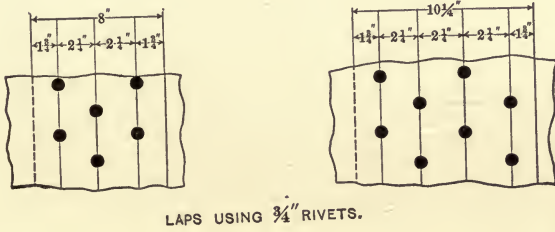
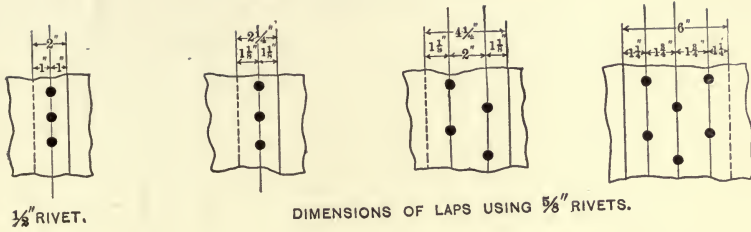

FIG. 45.

The sizes and spacing of rivets for marine-, boiler-, and tank-work, requiring water- and steam-tight joints, is somewhat different from that demanded for structural work, such as bridges, buildings, and towers. For structures of the latter type, the following general rules are applicable:

RIVET-SIZES AND SPACING FOR STRUCTURAL WORK.

(DU BOIS.)

Diameter of rivet-hole: Not less than thickness of thickest plate through which it passes. For cross-girders, stringers, compression-members: $\frac{3}{4}$ - to $\frac{7}{8}$ -in. rivets.

General rule: Diameter of hole = $1\frac{1}{4}$ thickness + $\frac{3}{16}$ in.

Number of rivets: Divide total stress transmitted by joint by product of diameter of rivet by thickness of plate by safe bearing-value per square inch of rivet material.

For number of rivets to resist shear: Divide total stress by product of area of rivet, by safe shearing-value. (Shearing-values used in practice are 6000 to 7000 lbs. per square inch.)

RIVET-SPACING FOR STRUCTURAL WORK.

Assume shearing strength equal to tensile strength.

p = pitch; d = diameter of rivet; t = thickness of plate,

and a = section of rivet. $p = \frac{a}{t} + d$.

Practical restrictions: Rivets should not be closer than 3 diameters, nor more than 6 inches, centre to centre. In compression, never more than 16 times thickness of thinnest outside plate. Distance from centre of rivet-hole to edge, end, or next row of rivets should not be less than 2 diameters of rivet. The following table is the Carnegie Steel Company's practice for structural work:

CARNEGIE STANDARD SPACING AND DIMENSIONS OF RIVETS FOR FLANGES OF I_c-L_s & L_s

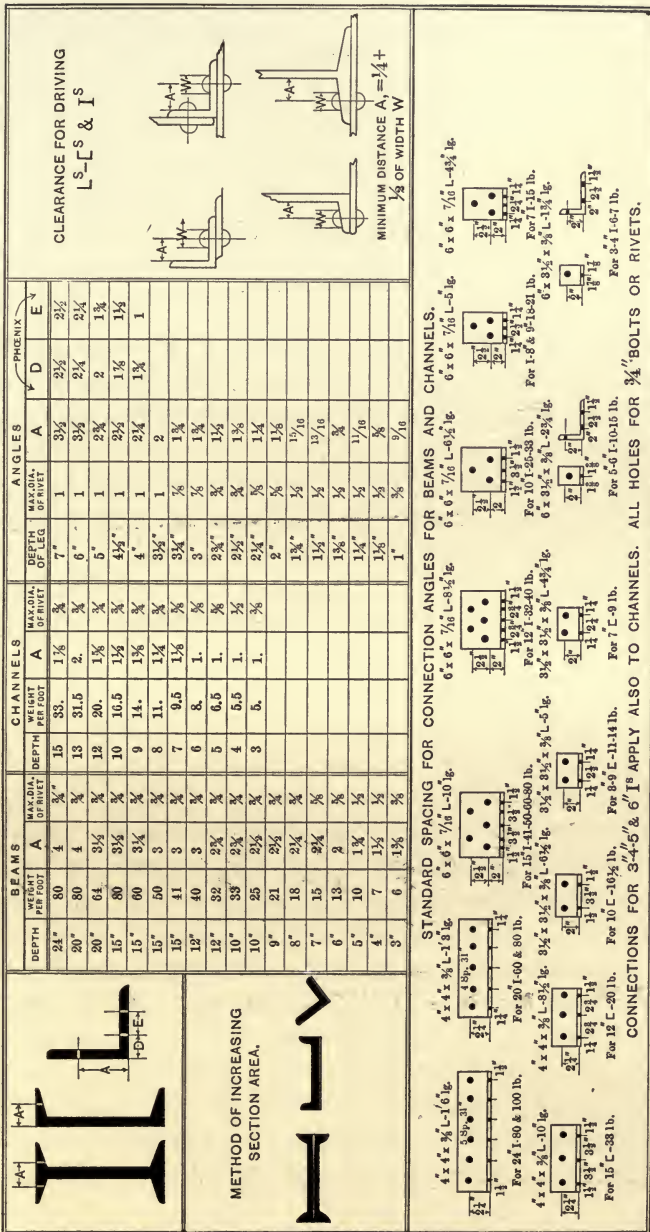

CHAPTER VIII.

DESIGNING.

HAVING formed a clear conception of the principles explained in the preceding chapters, it is possible to consider intelligently the subject of designing metallic reservoirs and their supporting substructures.

By the use of the various tables, applicable to included sizes, the study of suitable design is greatly facilitated and simplified. In the general scheme of a water-supply system, where storage and gravity supply is included, in the absence of a sufficiently elevated natural location, the necessity for some form of metallic reservoir to supply or supplement the deficiency is apparent.

From the general requirements as to pressure and storage, the dimensions of the structure will be determined.

From the analysis of "Stand-pipe Statistics," page 8, it has been found that the average domestic pressure, as required in the United States, is 61.2 lbs. per sq. inch. If this pressure is satisfactory to the designing engineer, as shown on page 65, the corresponding height or head is approximately 142 ft., which would be the required height of the stand-pipe. Under ordinary conditions, however, the local topographical condition is likely to afford certain convenient natural elevations, advantage of which may be taken to reduce the height of the metallic reservoir, which height, supplemented by the natural elevation, will give the required pressure.

In the case of a particular design, where there occurs an

available natural elevation of 22 or 23 ft., representing a pressure of say 10 lbs., the difference between this and the required pressure of 61.2 lbs. is 51.2, and which we see (page 65) represents a head of 120 ft. approximately; and we therefore determine to erect a stand-pipe 120 ft. in height, and, having assumed the height, the capacity required fixes the dimensions.

The question of capacity is settled most arbitrarily; but, in general, it is the usual practice to provide a storage or reserve supply which will permit the temporary stoppage of the pumping-engines for repairs, etc., for a given number of hours. In small towns, particularly where a lighting-plant may be operated in conjunction with the water-works, it is sometimes deemed desirable to provide sufficient storage to supply the ordinary consumption during the day by the pumping done at night, making only one set of firemen and engineers necessary for both plants. Another determining element in fixing the capacity of storage and the corresponding size of the reservoir is, of course, the item of cost and the amount of money available. As has been shown, the widest range of practice in the matter of diameter, height, and corresponding capacity exists; but, for the purpose of discussion and analysis, we will assume that a metallic reservoir of 400,000 U. S. gals. is required. The height having been taken as 120 ft., from the table (page 95), we see that, for the given height and capacity, the diameter will be approximately 24 ft., the actual capacity for the cylinder, 120×24 ft., being 407,150 U. S. gallons.

Strain-sheet.—In designing such a structure, through the employment of the principles previously enunciated, the details can be specified; their correctness demonstrated mathematically, or shown graphically.

Usually a graphic demonstration of the correct principles of construction is shown by a "strain-sheet," similar to that

shown below. . . . The line $H'B$ is first drawn, at right angles to which the vertical line HH is laid off. By any convenient scale, point off or divide the horizontal and vertical lines into equal subdivisions.

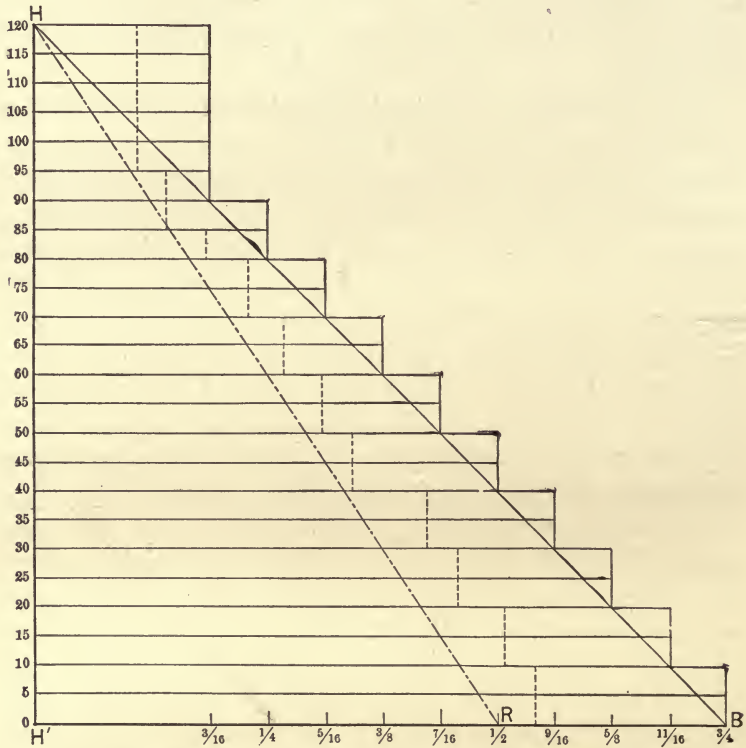

FIG. 47.—STRAIN-SHEET, 24 X 120-FT. STAND-PIPE.

The subdivisions of the horizontal line can be taken to represent the decimal or fractional parts of an inch, the latter being usually the case, as the thickness of steel or iron plate is generally considered in fractions of an inch. The value to be given the horizontal subdivision will depend upon the intentions of the designing engineer; that is, whether he

intends to construct his stand-pipe of plate advancing by 64ths, 32ds, 16ths, or 8ths of an inch. Usually the thickness of the plates to be used in the ascending sections or rings are decreased by 16ths; but, in close calculations, the scale is taken at 32ds, and in which case the value of any subdivision would be one thirty-second on the horizontal line.

The value given to equal subdivisions of the vertical line $H'H$ can be taken at decimals of 100 ft., and represent the height of each panel or ring taken in the clear—that is, between laps. The height of the rings is generally uniform, but is entirely arbitrary, the limiting height being determined by cost and convenience of handling; thus, a stand-pipe with a greater number of shorter rings would require a greater number of connecting joints, with increased cost of rivets, punching, and driving, as well as decreased efficiency in the general strength of the structure, than one with greater height of ring and fewer joints; but the larger the plate which is to be used in the construction of the ring, the more difficult it becomes to handle, both on account of the increased weight and the trouble given by the wind catching the broad expanse of plate metal, swinging and swaying it in the most troublesome manner as it is being hoisted into place.

It has been found from practice, both in shop- and field-work, that a 5-ft. segment is a very convenient height, and therefore the practice of making the rings 5 ft. in the clear seems to be in general use. Assuming that this height will be adopted, the value of the subdivisions of the vertical scale would be 5 ft.

The increasing height on the vertical scale, in multiples of five, is usually indicated as shown on the strain-sheet, as is also the increasing thickness on the horizontal scale, advancing by 16ths, 32ds, etc., as may be determined in advance.

Application of Mechanical Principles.—The formula for arriving at the theoretical thickness of plates is explained on

page 91, and calculations suited to a wide range of heights and diameters of metallic cylinders have been given, so that between these ranges it is only necessary to revert to the tables to find the required theoretical thickness of the metal in fractions and decimals of an inch corresponding to the required height and capacity.

Thickness of Plate.—Considering a 24-ft. \times 120-ft. stand-pipe, the theoretical thickness of the lower plate is seen to be $\frac{3}{4}$ of an inch.

Determining to advance by 16ths, twelve subdivisions of the horizontal line equal $\frac{3}{4}$ of an inch thickness of plate. Draw the diagonal line $H'B$, which is a line which indicates the theoretical thickness of the plate from zero at H , and where the thickness and strength of a piece of letter-paper is capable of resisting the pressure of the water, to B , where $\frac{3}{4}$ of an inch of steel, having a tensile strength of 60,000 lbs., with a factor of safety of 4, and a rivet-efficiency of $\frac{2}{3}$ the ultimate strength of the plate, is required to safely resist the hydrostatic pressure of 51.97 lbs. per square inch.

From the subdivisions of the vertical line $H'H$, draw perpendicular lines parallel to the base-line, with a distance apart of 5 ft. by the assumed scale, and with each length equal to the theoretical thickness of the plate, measured by the scale of the base. The length of these lines, representing the theoretical thickness of the plate, can be determined mathematically by the formula given, or from the table, as was done when establishing the thickness of the lower plate; but, to simplify this process, the length of each horizontal line can be determined graphically by terminating that line at the intersection formed by vertical lines, projected from the scale of the base, but which are not usually indicated except to complete the parallelogram.

If the parallelogram as thus formed lies inside of the diagonal line, the plate of which it is intended to construct

the ring is less than the required theoretical thickness demanded by the formula for the assumed conditions. If the parallelogram projects beyond the diagonal, the plate has greater thickness and strength than is theoretically necessary to resist the hydrostatic pressure at that point, the projecting area representing the excess of thickness and weight of the plate metal, and to that extent increasing the cost of the structure; in the same way the area included in the section between the diagonal and the vertical line when the latter is within the diagonal represents the proportion of insecurity. Obviously, the nearer the vertical projected line, intersecting with the horizontal, approaches the diagonal, the more nearly are the theoretical conditions of thickness of plate to applied pressure complied with; hence, in graphic design, the decrease in thickness of plate, corresponding with reduced pressures, should be shown as rising like steps along the diagonal, the foot of each rise just touching the diagonal line, and the three intersecting lines forming triangles whose area represents the excess of strength and plate metal beyond the theoretical requirements. This will be clearly understood by a slight study of the strain-sheet on page 164.

Joint Efficiency.—It is also customary to indicate upon the strain-sheet, graphically, the joint efficiency, or the percentage of strength of the joint as compared with the strength of the plate, showing by vertical dotted lines in each section the ratio of strength which the specified character of the joint bears to the strength of the solid plate.

In the formula for determining the thickness of the plate to resist safely the applied pressures, it was assumed that $\frac{1}{3}$ of the strength of the plate would be lost by punching and riveting; hence the line indicating the relative efficiency of the joint, or the "rivet-efficiency line," should be drawn to represent 66.6 per cent. of the theoretical strength of the plate as indicated by its thickness as measured on the scale or base-line.

H'B. Thus, where the scale of the base is taken in 16ths, $\frac{3}{4}$ of an inch thickness will be represented by twelve subdivisions, which, multiplied by 66.6 per cent., gives 7.99 as the distance of the point where the rivet-efficiency line cuts the base to the point *H'*.

Draw the dotted diagonal *H-R*.

For each ring or panel the distance of each vertical dotted line from the dotted diagonal will graphically demonstrate the excess or decreased strength of that particular joint more or less than 66.6 per cent. As in the explanation of the proper relation of plate thickness to the diagonal theoretical line of strength, so the dotted vertical, showing rivet efficiency of the particular vertical joint, should not fall very far on either side of the 66.6 per cent.-rivet-efficiency line in any section or ring; otherwise the joint will be too weak for safety in the one case or unnecessarily strong, entailing increased cost, in the other.

It has been previously explained how the efficiency of a riveted joint was determined, and from the formula deduced a set of tables has been calculated; it is therefore only necessary to inspect the strength and efficiency of any joint as shown in the table, and to adopt and specify the character of joint, giving the requisite percentage of strength; then for any ring or section whose thickness is known and indicated on the vertical scale, multiply the number of subdivisions representing that thickness by the per-cent. efficiency of the accepted joint, and the result can be used to plot the point where the vertical dotted line should be drawn, as was done to establish the point *R* on the base-line *H'B*.

The strain-sheet given for the 24-ft. \times 120-ft. stand-pipe, and further above explained and described, is frequently more or less elaborated to include other details, and is sometimes so complete as to render further specifications unnecessary for designing. Further details for this stand-pipe are given on the following page:

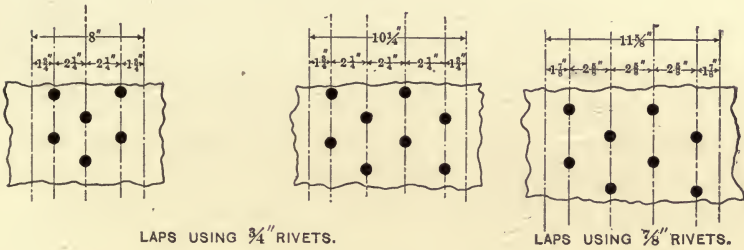
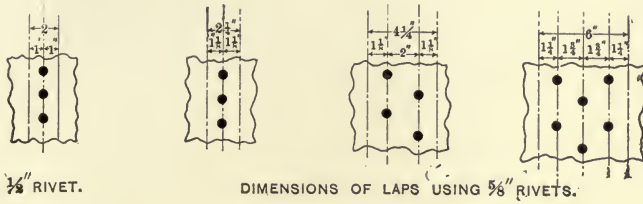

DETAILS OF RIVETED JOINTS.

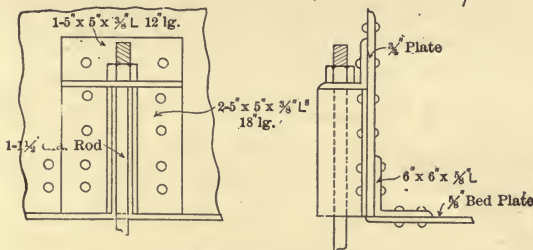
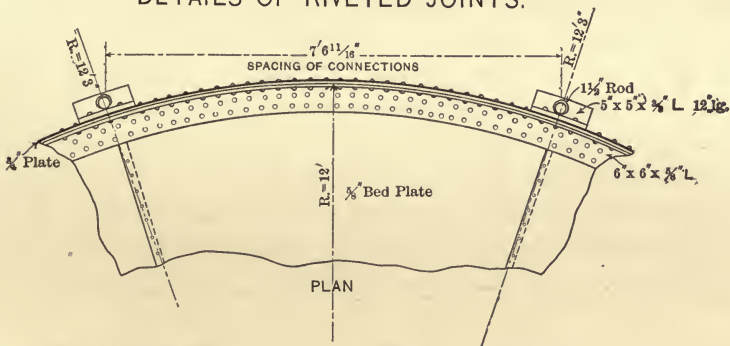

FIG. 48.

Bed-plate and Connections.—In calculations for the thickness of the “bed-plate” or the plate which is to form the bottom of the cylindrical stand-pipe, the moment of the weight of the column of water, acting through the centre of gravity and applied at the centre of the circle, would be found by multiplying the weight by its leverage, the radius of the circle, and the thickness of the plate to resist this stress would be found as explained; but in stand-pipes the bed-plate rests upon and is supported by the subfoundation, so that it is only necessary to provide a plate which can be satisfactorily joined to the shell. In practice where the shell-plate, bottom ring, is $\frac{1}{2}$ in. or over in thickness, the thickness of the bed-plate is assumed at $\frac{3}{4}$ the thickness of the shell; where the bottom ring is less than $\frac{1}{2}$ in., the bed-plate is taken as the same thickness as the shell. In large stand-pipes the bed-plate sheets are cut economically to represent segments of the circle, are riveted together in the field, and joined to the shell by some form of “angle” or “L” curved to radius. The length of the legs of the angle are determined by the character of riveting required, sometimes it being sufficient to single-rivet both legs to the shell- and bed-plate respectively; sometimes the shell is double- and the bed-plate single-riveted; sometimes both are double-riveted, hence the comparative lengths of the angle-legs. On page 87 it was shown that the maximum bending moment per square inch of circumference was $S = \frac{M}{A}$, then for a tank 24 ft. diameter by 120 ft. in height, and where the dead weight or weight of the metal is roughly 85 tons, $M = 86,400 \times 720 = 62,208,000$ pounds-inches. The area A of the tank being 65,144 square inches, the maximum bending stress per circumferential inch is $\frac{62,208,000}{65,144} = 955$, which multiplied by its leverage, 144 inches, gives 165,024, divided by the allowable unit stress of the metal, 15,000, gives 11 as the section modulus, and found from standard section tables to approx-

imate an angle 6 in. \times 6 in. by $\frac{1}{16}$ inches, without considering the plate of which the tank is composed. The connecting-angle is sometimes placed inside and sometimes outside of the cylinder, but as the pressures are from the inside, the outside angle location is preferred, as the bed-plate then extends beyond the shell, and the angle riveted on acts as a brace, and the plate and leg of the angle give that much additional stability to the structure. Some engineers prefer to flange the shell- and bed-plate, making a flanged joint instead of the angle-joint as described. Where it is unnecessary to extend the area of the base by the use of angles and web-plates, and the simple angles are used, as shown, the outer arrangement of the connecting-angle is impossible, and the connection is necessarily made on the inside.

Details.—As has been said, the hydrostatic pressure at the top of a tank being zero, the thickness and strength of a sheet of paper would be sufficient to control and restrain the pressures and water; but, in stand-pipes of any size, the thickness of the top rings is usually $\frac{1}{4}$ in., and never less than $\frac{3}{16}$ in. These thicknesses are used to provide for the weakening of the plates by oxidation or rusting of the metal, and also to resist the action of the wind, to successfully resist which it is usual to provide some “stiffener” at the top, usually an angle riveted to the inner or outer circumference of the cylinder, the horizontal leg being used to fasten and support an ornamental cresting, generally of malleable iron, cast in segments, and bolted to the angle.

In the record of stand-pipe failures, several large structures have suffered partial or total collapse during high winds, the metal being rolled up at the top into a cone shape, similar to the twisting of a piece of paper into a taper. This action of the wind is not very well understood, and therefore the size of the stiffening angle customarily placed about the top of the stand-pipe is generally arbitrarily assumed.

As has been said, at the top of the tank the strain from the water is zero, and considering the cylinder as a stack under wind-pressure the vertical components of the uplift may be regarded as negligible, and there remains principally the consideration of the wind normal to the tank, which force probably exercises also a torsion movement and is also known to produce a vacuum within the cylinder and on the leeward side of the structure, for which reasons the stresses are generally considered as indeterminate, nor is it possible with certainty to assume the resistance offered by the shape, which is probably somewhere between the arch and beam action.

The effect of these stresses is graphically shown on page 28



in the wreck of the Lincoln, Neb., stand-pipe, whose top angle was broken and the shell plates were crumpled up for some 40 feet below the top, and from which the necessity for making suitable provision for wind-pressure is obvious.

In general practice a 10-ft. diameter tank should be provided with an angle not less than 4 in. \times 4 in.; a 20-ft. diameter tank with 6 in. \times 6 in. angle, and for pipes of larger diameter some form of stiffening girder, and which might also be utilized as a part of an ornamental design, should be introduced.

This style of finish for the top of a stand-pipe, while in general use, is subject to criticism in that it is uncovered, and in some waters the sunlight quickly forms organic growths, while the angle without the cresting is an inviting roosting-place for birds—the writer having seen dozens of buzzards roosting upon the tops of stand-pipes so constructed; again, in cold climates an uncovered surface is objectionable on account of the greater tendency of the water to freezing, several recorded failures being ascribed in part to this cause.

A better construction is to provide for a light plate-metal cover, supported upon radial rafters of light angle or channel shapes, the rafters being bent to project vertically below the top of the stand-pipe and forming stiffeners for that portion of the structure.

In addition to these stiffeners spaced at regular intervals, a light horizontal stiffener should be provided, set 12 or 18 inches below the top; and, if a Z shape is specified, a suitable support for a painter's trolley is thus secured, which will be found most convenient!

For purposes of inspection a ladder capable of safely sustaining a weight of not less than 1000 lbs. should be designed, and is sometimes used both inside and out—that for the outside terminating 10 ft. above the base of the structure, to prevent mischievous or malicious persons from having too ready access to this facility. Such ladders may be composed of two side-bars, 2 ins. \times $\frac{5}{16}$ in., with $\frac{3}{4}$ -in. diameter rungs spaced 12 to 18 inches, which may also be a suitable spacing for the side-bars. Such ladders are generally built in sections at the shop, and are riveted to the sides of the stand-pipe at intervals of 10 to 12 feet with light angle-clips.

As it is sometimes necessary to empty the stand-pipe and to remove deposits, it is necessary to provide some kind of manhole near the base, which is usually of elliptical form, with plates, arches, and bolts, and of such dimensions as to provide easy ingress for a workman.

A suitable connection for the supply-pipe must also be arranged for, its dimensions being governed largely by the size of the inlet-pipe; the connection is usually a short bell-mouth section, flanged at both ends, the flange to be in contact with the plate to be curved to radius while the other end is planed for a standard flange-connection with the inlet-pipe, the first section of which generally has both a flange and bell end.

Method of Anchorage.—Beside those above described, suitable connections for the anchor rods must be designed and the number and size of the rods determined.

The method and formulæ given at length on page 87 are of general application.

Analyzing the stresses of the 24 ft. by 120 ft. stand-pipe under consideration, we find from rough calculation that the weight of the metal or the "dead" weight is some 85 tons, hence $M = 86,400 \times 720 = 62,208,000$ pound-inches.

The area A of the tank being 65,144, the maximum bending stress per circumferential inch is $S = \frac{M}{A}$ or $\frac{62,208,000}{65,144}$, gives 955, which multiplied by the length of the arc included between the anchor rods (assuming 10 to be sufficient, and spaced along the outer circumference of the tank, but sufficiently removed to allow for the connection and for the use of a tightening wrench) and to an assumed radius of 12 ft. 3 inches, the circumferential included arc would be 92.4 inches which, when multiplied by the unit stress, 955, would produce a total maximum wind reaction of 87,242 lbs. acting on any one rod. The weight of the tank being estimated at 170,000 lbs., the *net* stress would be 87,272, less 17,000 or 70,272 lbs., which divided by the allowable working stress of 15,000 lbs. gives a cross-section area of rod equal to 4.685, or selecting the nearest approximate size, the required rod would be $2\frac{1}{2}$ inches in diameter.

Where the resultant of the forces passes too close to the base it is frequently considered good practice to add stiffening braces at intervals along the outer circumference of the tank. These generally consist of a pair of angles bent to bracket form with a web of steel plate riveted between. These braces give a greater leverage against the overturning moment.



TOWER AND TANK, WEST TAMPA, FLA.

CHAPTER IX.

DESIGNING—CONTINUED.

IN the general scheme of a water-supply plant, where storage is required and to be obtained only by the erection of a metallic reservoir, it is sometimes deemed expedient to secure a suitable elevation by constructing the tank upon a supporting tower. Such towers are made in many ways and of various materials, brick, wood, and metal being most generally used. The choice of such substructure is determined by the conditions of capacity, cost, and local surroundings.

As to the question of capacity, the same considerations apply as those explained previously for stand-pipes.

The height of the tank superstructure may be considered as representing the minimum and maximum desirable or limiting pressures, hence it is argued that a stand-pipe has a large column of water which is useless except to support the *effective head* of water above the minimum desirable pressure as determined in feet, and that the effective column may be more economically supported by an open substructure, such as a steel tower. Arguments are also presented that the lower volume of water in a stand-pipe being useless except for purposes of support, it is objectionable from the fact that it is stagnant and the greater volume of water is more liable to be affected by organic growths. This argument is controverted upon the assumption that the temperature of the water is constantly changing and therefore all sections of the column are equally fresh. It is a fact, however, which is used to the best purposes by builders of this type of

structure, that the record of failures shows that fewer towers have failed as compared with the collapse of stand-pipes.

While this is true, it is also a fact that in the United States there are very many more stand-pipes in existence than towers and tanks, but on account of the comparatively small increased cost of securing a greater area of bearing surface for the support of the structure, and also from the fact that by the wide spread of the supporting columns of a tower, the stability of the structure can be so increased that the resultant of the overturning moment of the wind and the moment of the weights falls well within the figure limited by the spread of the columns, where the same resultant could only be secured for a stand-pipe by an abnormal area of base.

The local character of the bearing soil exerts a considerable influence upon the selection of either type of structure, and this factor should be carefully considered in connection with the discussion of foundations, as explained in the succeeding chapter.

If, after a careful consideration of the conditions from both an engineering and a financial standpoint, it be determined that a tower-and-tank type of reservoir is preferable, the dimensions of the tank being assumed from reasoning analogous to that given in considering the factors in stand-pipe design, a strain-sheet is prepared as explained in the preceding chapter, but which will necessarily be modified, as will be explained hereafter, as far as the thickness of the lower ring and bottom plates are concerned; the conditions for their determination being changed.

In small railway water-supply tanks flat or horizontal bottoms are usually provided, supported upon wooden sills or I beams of iron or steel, attached to the upper deck of the supporting structure. In such cases the thickness of the lower ring is that determined by the formula, but the thickness of the bottom plate will depend upon the spacing of the beams or sills.

In cities or towns where the tower and tank is to be erected for public supply some other form of bottom is generally specified,

for the reason that other forms require somewhat less material; it is easier to secure and maintain water-tight joints; all parts of the bottom are accessible, making subsequent and necessary painting possible; the stresses are less than in the flat bottom; the conical, hemispherical, or compound-shaped bottom is more symmetrical and pleasing to the eye; and, last, the action of the effluent exerts an automatic scour or self-cleaning effect upon the bottom plates, preventing sedimentary deposits, which are sufficient, as has been shown in the discussion of flat-bottomed stand-pipes, to make it necessary to provide some form of man-head permitting ingress for removal of the deposit at intervals. For these reasons the subsequent discussion of suitable bottoms will be limited to this type.

Fairhaven Failure.—Since the complete and disastrous failure of the pretentious and costly water-tower at Fairhaven, Mass., brief mention of which has been made in a previous chapter, attention has been particularly drawn to the proper design of tank bottoms, their connections, and the importance of the continuous girder construction. Shortly after this failure numerous articles were contributed to the technical press, the most logical of which is that prepared by Prof. A. Marston, Civil Engineering Department, Iowa State College, and published in the *Engineering News*, Dec., 1901, as follows:

“I have been very much interested in the account of the Fairhaven water-tank failure published in your issue of November 21. I desire to call your attention to some features of the original design and of the modifications of that design made during construction which were not mentioned in your account of the failure, and which, it seems to me, whether they did or did not actually cause the failure, may readily have done so. In what I shall say I do not desire to be put in the position of in any way criticising the engineer who prepared the original designs. The Fairhaven water-tower was a pioneer structure of its kind. In most engineering designs some features cannot be calculated and

must be designed in accordance with the results of experience. In the case of the Fairhaven tower experience to point out features requiring special attention in the design was lacking. Again, very serious changes (see *Engineering News*, Nov. 21, 1901) from the original design were made in the construction of the tower, and I consider that these added greatly to the danger of failure. The engineer who designed the structure cannot be held responsible for its failure, in my opinion.

"In Fig. 49 I have reproduced your sketch (with some additions) showing the methods of supporting the tank at the tops of the posts.

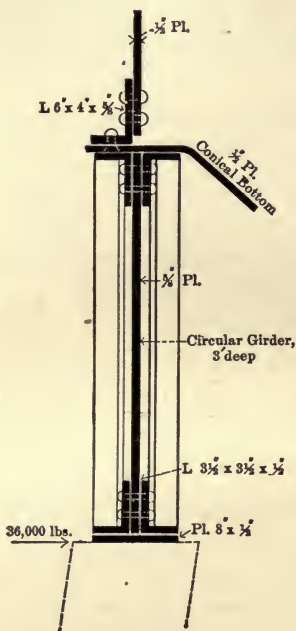

FIG. 49.

Owing to the posts having a batter, the post thrust against the bottom of the circular girder will have an inward horizontal radial component. From the original description of the tower published in *Engineering News* of Sept. 5, 1895, I judge that the batter was about 1 to 8. With the tank full the horizontal radial component would, therefore, be about 36,000 lbs., as indicated in Fig. 49. No special provision appears to have been made in the design to take care of these radial pressures, except as the lower flange of the circular girder may be capable of withstanding them. In all designs for water-towers these forces should be provided for, and usually are provided for by the use of a circular girder with

its web horizontal. The company which builds more such structures than any other in the country uses solid-plate webs. The writer is accustomed to use a web system for this circular girder composed of angles. Usually this girder is utilized to

form the floor of the balcony, which I consider a very important feature of water-tower designs, as it enables convenient and careful inspection to be made of the portion of the tank which is most liable to failure, namely, the junction of the tank with the supporting posts. In the case of the Fairhaven tank, if we consider the horizontal radial components of the post thrusts to be carried only by the lower flange of the circular girder, and if this lower flange had been made continuous past the posts, a bending moment of 331,000 inch-pounds and a thrust in the line of the flange of 67,000 lbs. would result immediately over each post. Counting the lower flange as composed of two $3\frac{1}{2} \times 3\frac{1}{2} \times \frac{1}{2}$ -in. angles, and one $8 \times \frac{1}{2}$ -in. cover-plate (see *Engineering News*, Sept. 5, 1895), and also counting in $3\frac{1}{2}$ ins. of the $\frac{5}{8}$ -in. web plate of the circular girder, the resulting stress on the outer fibre would be 38,400 lbs. compression at the post connection. As built, the lower flange seems not to have been continuous, and this bending moment would have to be carried by the rivets of the connection between the segments of the circular girder with each other and with the top of the posts. No data of the connection have been published which would enable the resulting stresses upon the rivets to be computed, but under any reasonable assumption it seems probable that they must have all along been stressed nearly to the breaking point whenever the tank was entirely full of water.

“As the formulas for the computation of the stresses given above are not widely published, the writer here gives them, crediting them to two students of the Civil Engineering Department of Cornell University (Transactions of the Association of Civil Engineers of Cornell University, 1896.)

“At any point A in the circular hoop shown in Fig. 50 let the bending moment from the pair of radial forces, P , be called M , the thrust T , and the shear J . Then

$$M = Pr \left(\frac{\sin \phi}{2} - \frac{1}{\pi} \right); \quad T = \frac{P}{2} \sin \phi; \quad J = \frac{P}{2} \cos \phi.$$

“In addition to the above critical stresses in the circular girder, it should be observed that if this girder fulfils the purpose for which it was intended, that of transferring the weight of the tank to the posts, it will be subjected to a large bending moment immediately over the posts, of such nature as to cause tension in the upper flange and compression in the lower flange. This compression in the lower flange has to be added to the stresses already given, and in addition it should be noted that each segment of the circular girder would have a tendency to rotate inwards at the top of the post connection owing to the fact that it is not straight between posts. Cer-

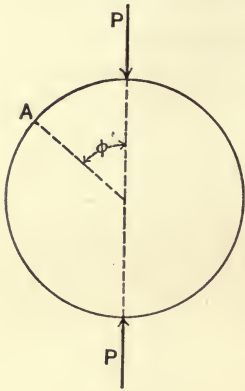

FIG. 50.

tainly the circular girder should have been made continuous as provided for in the original plans, and the fact that it was built in segments renders the upper flange incapable of carrying the tension over the posts, and this tension, so far as the friction from the heavy load can do this, would be transferred to the flanged portion of the conical bottom, tending to disrupt it along a radial line.

“The writer does not consider it necessary or even desirable to use a circular girder under the sides of the tank. There is no way of preventing the tank itself from acting as a girder to carry the loads to the posts if we desired, and the writer considers that it ought to be strengthened sufficiently to enable it to do this with safety. The writer would not put any manhole in the lower ring of plates of the tank.

“In the case of the Fairhaven tank, the lowest side ring of plates appears to have been made of just about the thickness that good practice would require for a stand-pipe of diameter and height equal to the tank above this point. Now, the conical bottom at its junction with the sides of the tank is subjected to

bursting stresses greater than those in the sides of the tank in the ratio $\frac{1}{\sin \theta}$, where θ is the angle which an element of the cone makes with a horizontal line. I am unable to tell exactly what θ was in the case of the Fairhaven tank from any published data, but presume that it was in the neighborhood of 45° . If θ equals 45° , the upper ring of plates in the conical bottom was overstressed about 40% beyond what good practice would indicate as reliable. In addition comes the stress over each post due to the fact that the circular girder was made in segments instead of continuous.

“Under the circumstances indicated above the writer does not consider the failure of the tank a matter for surprise. It may readily have happened that the lower flange of the circular girder, after having been repeatedly stressed beyond the elastic limit, may have bent inward at some post. The result would be a redistribution of the stress which would be pretty sure to tear the tank at its weakest point, which in this case was the conical bottom. The first indication of failure visible from the ground would be a stream of water escaping from this tear, which would be immediately followed by the collapse of the structure. The writer considers this the most probable way in which the failure occurred, but if for some unknown reason the bottom disrupted first, the fact that the circular girder was in unstable equilibrium, so to speak, would lead to the immediate collapse of the structure. The writer considers that the lessons to be drawn from the failure are that in the design of elevated steel tanks:

“1. A larger factor of safety should be used for the curved bottom than for the vertical sides of the tank.

“2. The lower portions of the vertical sides of the tank should be strengthened to resist the shearing and other girder stresses caused in them by transferring the load to the posts.

“3. The junction of the bottom and sides of the tank should be held true to shape and the radial components of the post

thrusts should be provided for by a circular girder extending entirely around the tank and having its web system horizontal.

"4. A balcony should be provided at the junction of the bottom and sides of the tank, to permit ready inspection of this most important part of the structure.

"The writer will add that it is very important that the loads should bear centrally on the posts, or that the stresses due to eccentricity of loading should be amply provided for."

Consideration of Tank Bottom and Connections.—During the prolonged discussion of the Fairhaven failure Prof. A. Marston again contributed a short article with details of a full hemispherical tank bottom and connections, which was published in the *Engineering News* of January, 1902, and this design is reproduced here as Fig. 51.

In the article alluded to, Prof. Marston expresses his decided preference for this type rather than either the segmental or conical bottom, urging that the latter introduces a radial inward pull on the joint, liable to cause trouble. It was also pointed out that the stresses in a hemispherical bottom are only one-half, while those developed in the conical bottom are larger than those in the vertical sides of the tank; therefore, by using for the bottom the same thickness of plate as theoretically determined for the shell, the hemispherical bottom would develop a factor of safety twice that provided for the vertical sides.

In the consideration of this type entirely in its commercial and practical aspect, an expression was asked of a representative of one of the great bridge companies, himself an expert in the design and construction of such structures, and who replied in part as follows: "The objection to the hemispherical bottom from the manufacturer's point of view is not nearly so strong as it was a few years ago, and there is now no difficulty in getting competitive bids on the manufacture of the spherical bottom. The additional costs of labor required for manufacturing spherical bottoms are usually more than offset by the saving of material

and freight. It seems to me good policy to advocate that form of bottom which gives definite stresses, even though that form of construction may cost more in some cases.

“The plates of the spherical bottom should be made about $1/16$ of an inch thicker than the figured thickness, to make allowance for the stretching of the plates in shaping them and to give protection against masses of falling ice.

“Similarly the connection of the bottom to the cylinder should be made stronger than the figured stresses required.

“Whether the conical or hemispherical bottom is used, I would prefer to connect same to the bottom of the tank cylinder so that the metal forming the joint is a part of the bottom of the circular girder.

“The post connection is not so easy to make, but it can be satisfactorily solved. The design for the water-tower for the Iowa State College, at Ames, Iowa, published in recent editions of Johnson's ‘Framed Structures’ gives a satisfactory solution of this connection. This structure was designed by Prof. A. Marston (Figs. 51-52).

The detail which shows the posts riveted direct to the tank shell has proved very satisfactory, as it gives a rigid connection. However, care must be taken that the centre of gravity of the connection falls on the axis of the column. Theoretically the curved girder in the horizontal plane which resists the horizontal thrust at the top of the posts should be at this centre of gravity. Practically it is more convenient to place it on a level with the junction of the bottom and cylinder. This arrangement produces some bending stresses in the post and its connections, but ordinarily they will not be serious.”

In bottoms and connections of this type especial care should be taken in the matter of “laying out” and shop-work, and it has been suggested that for the joint between the sides and bottom the pieces should be assembled at the shop and rivet-holes reamed through; also that adjacent pieces of the bottom should be fastened

together in the shop and those of one piece marked from the holes of the other.

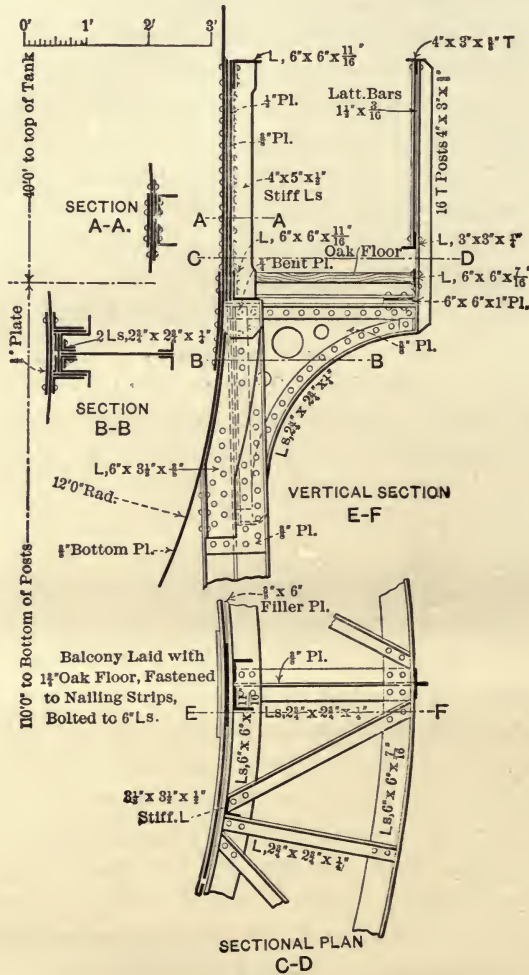

FIG. 51.

No heating or excessive hammering is necessary or should be permitted. The bottom and connection as shown in Prof.

Marston's design are not novel in their general character, as this type has been used exclusively as a specialty of a large Western bridge and structural works, which has erected from eighty to one hundred water-towers with spherical bottoms for towns, cities, and industrial plants, the largest being a tank 32 ft. in

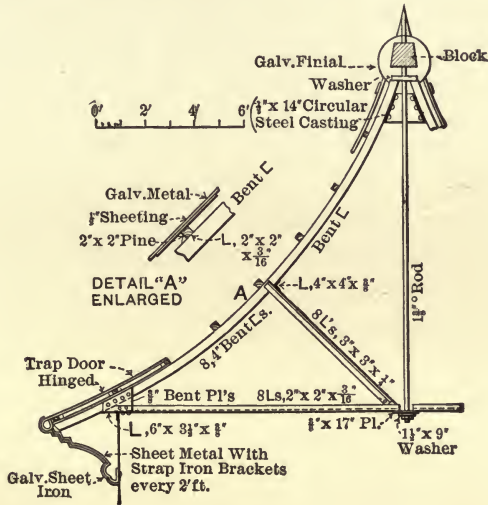

FIG. 52.

diameter, and with a shell, exclusive of full hemispherical bottom, 40 ft. high. The capacity of this tank is 300,000 gallons.

Prior to the Fairhaven failure, the Jacksonville, Florida, water-tower had been constructed, brief mention of which has been previously made. As stated, this tank was 30 feet in diameter and 45 feet high, with conical bottom and connections as shown in Fig. 1.

In its general appearance this tower was very similar to that at Fairhaven (Fig. 3), although differing in its design for bottom connections and other structural details.

The simple post connections of the Jacksonville type, as well as the ease in laying out and assembly, have made this a most

popular form for manufacturers, and it is undoubtedly true that for these reasons closer figures have been obtained and broader competition secured when this class of bottom and connections have been specified. In the recent past nearly all of the smaller water-works tanks have had the conical bottom except those designed and erected by the structural works making a specialty of the spherical type as hereinbefore mentioned. To offset its advantages, it has other faults beside those of indeterminate stresses, and necessity for heating and flanging its segments, principally structural reasons, as, for instance the difficulty in driving a few of the rivets in the radial seams of the bottom and the vertical seams of the cylinder; besides there is a difficulty in painting in the angle between the bottom and the cylinder. The first coat would probably be properly applied, but this inaccessible and out-of-the-way recess would very likely be subsequently neglected, exposing this vital point of the structure to corrosion.

Notwithstanding these facts, with the exception of the Fairhaven tank, which is hardly a satisfactory type, no failures have to this time been reported, and such towers have generally proved entirely satisfactory. In one of his own designs (Fig. 53) the author has combined the two types, using a spherical segment for the section of the bottom intended to be riveted to the tank, which segment is tangent to a cone-shaped lower section, terminating at the orifice.

The Circular Girder.—In the theoretical discussion of the circular girder it was shown that the stresses produced were a vertical shear, a torsion moment, and bending moments between and over points of support. Since the maximum stress is the bending moment over the point of support, in the consideration of the girder, the shear and torsion stresses are not generally of prime importance, although all of the stresses produced should be given attention. These stresses have been analyzed and tabulated for girders having from four to twelve points of

support, and are included in the chapter "Stresses in a Steel Water-tower."

On account of the maximum stress and heavy bending moment over each point of support, it cannot be too strongly insisted upon that prudence demands provision for a continuous curved girder. While it is true that a number of water-towers have been built without the use of the circular girder other than the tank cylinder itself, the only provision being an increase in the thickness of the lower tank ring over that required for hydrostatic stresses, such practice is likely to cause trouble, and a girder should be designed with a web consisting of the lower plate slightly heavier than theoretically determined as necessary, and reinforced with angle stiffeners, and provided with both bottom and top flanges. In discussing the riveted girder, Carnegie's Handbook has this to say: "The web of the girder must be made of such thickness that there will be no tendency to buckle and that the vertical shearing stress per square inch will not exceed 10,000 pounds.

"This shearing stress is greatest near the supports and is obtained by dividing half the load upon the girder (providing the load is symmetrically applied) by the web section. The first condition (security against buckling) is attained when this shearing stress does not exceed

$$11,000 \frac{d^2}{3000t^2},$$

in which d represents the depth of web in clear of flange of girder, and t the thickness of one web plate in inches.

"Ordinarily this formula gives a lower stress than 10,000 pounds, so that both conditions are usually attained when the first is. Instead of increasing the thickness of the web, it may be stiffened by means of vertical angles riveted to it at proper inter-

vals. These latter should always be less than the depth of the girder. . . . Stiffeners should always be used at or near the supports, and at any point where there is a concentration of heavy loads.

“The duty of these stiffeners in such cases is twofold: first, to prevent buckling of the web; second, to transmit the shear to the web by means of abutting areas and the rivets, both of which must be sufficient for the purpose.”

There has not to this time been formulated any rational theory for either the spacing or size of stiffeners in plate girders, although it has erroneously been assumed that when stiffeners are introduced at intervals not exceeding the depth of the girder, the conditions are analogous to those of a truss composed of posts and tension members and to the solution of which the Gordon or other compression formula might be applied. As a matter of fact, both size and spacing of vertical stiffeners are largely matters of judgment and are governed by the usual practice for particular cases. Allowable flange strains are usually taken as 15,000 pounds. The rivets generally used are $\frac{3}{4}$ -inch, spaced not more than 6 inches and closer than this for heavy flanges. Where loads are great, especial calculation for rivet-spacing should be made, allowing 9000 pounds per square inch for shearing and 18,000 pounds per square inch for bearing. The unsupported width of flange-plates subject to compression should not exceed 32 times their thickness, nor should the flange-plates extend beyond the outer line of rivets more than 5 inches nor more than 8 times their thickness. The term “flange” as applied to riveted girders embraces all the metal in top or bottom of girder exclusive of web plate; or in the case of a rolled beam or channel with top and bottom plates, all metal exclusive of that part of the web between fillets. With a circular girder as with a simple beam, its ability to support a load depends upon the strength and arrangement of its fibres, limited by the distance between supports.

Since the width of the girder is small compared with its radius, the solution of the stresses in a circular hoop may be applied, and the girder designed to resist the whole weight of the tank, including its own weight and the contents of the tank; a radial inward thrust at the top of each of the posts, and reactions due to wind stress.

In the riveted plate girder it is usual to assume that the flange sustains the horizontal and the web all of the vertical strains due to the load, the flange acting under tension and the web being subject to shear. The tank plate is usually taken as the web of the curved girder; angles are riveted to the web as flanges, and stiffeners are introduced at proper intervals consisting of one or more angles or channel shapes. Such a continuous girder, when properly proportioned, provides an economical and effective support for the gravity and wind stresses to which the tank is subject. To determine the safe load for the girder, its elements must first be found.

The principles of moments are applicable to areas as well as to weights, and from such application an equation is obtained from which the value of c , or the distance from the neutral axis, passing through the centre of gravity of the shape to the most remote fibres can be determined.

If a be any area and z the distance from its centre of gravity from an axis, the product, az , is called the static moment of the area. The sum of the static moments of all parts of the figure is represented by Σaz , and if A be the total section area, then

$$c = \frac{\Sigma az}{A}.$$

Since the moment of inertia of a plane surface with respect to an axis is the sum of the products obtained by multiplying each elementary area by the square of its distance from the neutral axis, the elementary areas of the compound shape and the dis-

tance c having been determined, their summation is the moment of inertia I , of the shape, and the moment of resistance R , of the girder, is $\frac{I}{c}$.

SUPPORTING TOWER.

For small tanks with capacities of from 20,000 to 30,000 gallons, possibly a three-post tower is the most convenient and economical type, and for such small structures presents a neat and trim appearance.

Larger tanks should be built of four, six, and eight columns, but for capacities of from 30,000 to 90,000 gallons possibly the four-post tower is more satisfactory on account of the material saved in the design because the compression members are of larger and more convenient dimensions than where the load is distributed amongst a greater number of supporting points.

The increase in the number of supports does not indicate a corresponding security and strength, but unquestionably especially tall towers and capacious tanks equipped with more than four legs produces a decidedly more stable as well as symmetrical appearance than the four-post variety, and in such cases, the loads will be large enough to require sections of economical dimensions.

Where a hemispherical-bottomed tank is specified and to be riveted directly to the columns, increasing the points of support allows a better distribution of the loads, and the likelihood of unequal loading is thereby minimized.

A majority of the towers are built with posts slightly inclined, and without change of inclination from the top to the base, although a few towers have been constructed with vertical legs, and of late several have been designed with change of inclination in the batter posts at panel-points, producing a pleasing curve in the tower outline.

In the latter case column sections are straight between panel-points, these being located upon the arc of a circle or at points of a parabolic curve, according to the fancy of the designer. Straight posts are somewhat cheaper, but the additional cost of the curved outline may be warranted on account of the improved appearance and more graceful lines.

Several years since column sections and formulas of structural engineering underwent careful investigation and analysis. This sharp rivalry for supremacy has produced its natural result, the survival of the fittest, until to-day all column sections are practically eliminated that fail to include standard elements, as I beams, angles, channels, and plates, and the standard-built column of to-day consists of angles latticed, angles and plates, and the latticed double channel, formed either of plates and angles or the latticed double-channel column.

The seeming exception to this rule is the Z-bar column, but as with the other discarded column sections, its popularity seems somewhat on the wane judging from the following expression of an experienced structural engineer: "These columns are excellent from a structural point of view, but are somewhat more difficult to use where bevelled connections are required. Furthermore, Zee-bar columns seem to be going out of use; just why I do not know, but at the present time the demand for Zee bars is comparatively light, and the result is that the mills do not roll them very often, and there are likely to be serious delays occasioned on work where Zee bars are specified. The quantity of Zee bars required for a water-tower is not sufficient to warrant a special rolling. In one case last year we were delayed three or four months for this reason. If the Zee-bar shape is specified for any reason, it can be built of an I beam and two channels. Laced-channel columns are very satisfactory, especially so for the rigid connection at the top referred to above. As all sizes of channels are used in large quantities, there is usually no difficulty in procuring them within any reasonable time."

The tendency toward standardizing is undoubtedly accountable for the facts presented.

In designing a girder capable of safely carrying all the imposed stresses, a reduction of the length of span and consequent decrease of the size and weight of the members of the circular girder may be accomplished by increasing the number of supporting columns; or the length of span may be reduced by designing short diagonal struts, usually two for each column, reducing the length of span in accordance with the number of

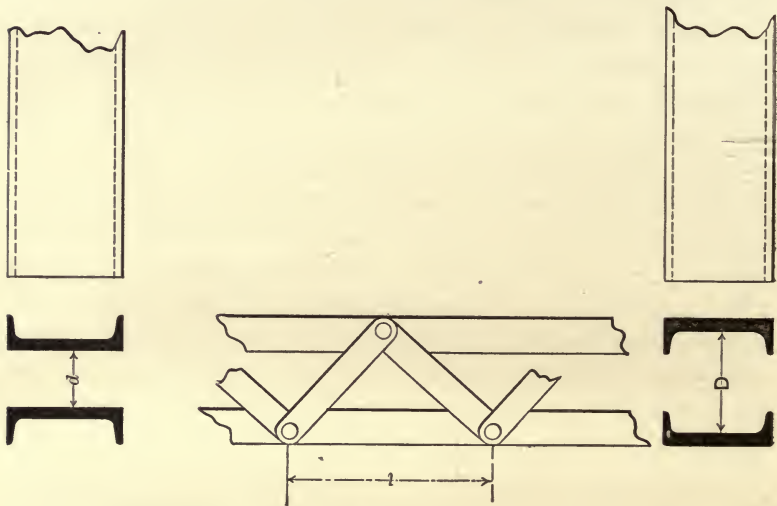

FIG. 53.

struts supplied, two such struts to each column of a four-column tower giving twelve bearing points instead of four along the curved girder; but this method of reducing the length of unsupported span is open to objection on account of the eccentricity of loading and the multiplication of members and joints.

The usual four-, six-, and eight-column towers being made up of certain standard shapes, is laid out and riveted together at the shop, and the lengths so constructed are carefully marked,

to be afterwards readily assembled in the field, and at which time only the riveting at the junction- or panel-points is necessary.

At this time the two favorite types are undoubtedly the Z bar and the double-channel latticed column, both possessing individual advantages for structural purposes.

Where the double channel is used, it should be so latticed as to prevent individual weakness and that all parts should act as a unit in the combined section. That there may not be a tendency in the channels to bend between the points of bracing, the distance l (Fig. 53) should be made to equal the total length of strut multiplied by the least radius of gyration of a single channel and the product divided by the least radius of gyration of the whole section, or $l = \frac{rL}{R}$,

where l = length between bracing;

L = total length of strut;

r = least radius of gyration of a single channel;

R = least radius of gyration of the whole section.

In practice the distance l is taken considerably less, the distance as determined by the formula being more or less used as a guide.

The Z-bar column, consisting of four "Z"-shaped bars riveted to a web plate possesses so many structural advantages that for building purposes it has had a wide popularity and extensive use, and whether the tendency toward standardization will render it obsolete remains to be seen, although this would seem the case.

In lengths ranging from 64 to 88 radii, from careful test, an average ultimate resistance of 35,650 pounds was determined for *iron* columns, and an assumption that steel bars will have some 20% higher value. Their great adaptability for making connections with other columns and members, their accessibility for inspection, painting, and repair, the small number of rivets

required for connection, make this a most excellent section for supporting columns of a water-tower.

Six-inch columns are manufactured from 12 to 30 feet long; 8-inch are from 18 to 40 feet in length, and 12-, 14-, 16-, 18-, and 20-inch columns are made as long as 50 feet. In the tower design, where junctions are made between lengths, horizontal struts are introduced between columns, and are sometimes inserted radially, the latter rather for the purpose of stiffening the tower than calculated as of theoretical value in transmitting stresses. There is also usually inserted at the foot of the tower a strut or tie. When this is omitted, as is sometimes the case, the foundation loads are not vertical, there being a horizontal component. This point should be taken into consideration in the design of the foundations, making the resultant of the loads on the foundation come in the centre of the bearing surface and thus avoid the liability of unequal settlement.

Horizontal members of the tower are subject to similar stress as the vertical columns, but it is to be noted that in particularly long lengths, the weight of the strut itself produces deflections that should be given consideration.

In water-tower design, such horizontal struts are generally formed of four angles back to back, and riveted either to a central web plate or to lattice bars, but where the span and load is considerable, the double-latticed channels are preferable.

Columns and struts generally fail under the stress produced by combined compression and bending.

The investigation of a column under a given load consists in computing the unit stress from formulas and then comparing this with the ultimate strength and elastic limit of the material, taking into consideration such conditions as the effect of a steady, variable, or sudden load with further reference as to how the column ends are secured.

When the length of the column and load to be carried by it is given, the design consists in selecting suitable materials and

proportioning the section so that the unit stress will be proper and reasonable. On page 105 column formulas are discussed and tables are given for the investigation and design of columns and struts, while, as has been stated, most of the manufacturers' lists furnish correct tabulation of the elements of the standard shapes.

GENERAL DETAILS.

Tank-cover.—Small water-towers are generally open at the top and are provided with a circumscribing angle, usually surmounted by a malleable iron cresting of ornamental design, but with tanks of capacities as large as say 50,000 gallons. The

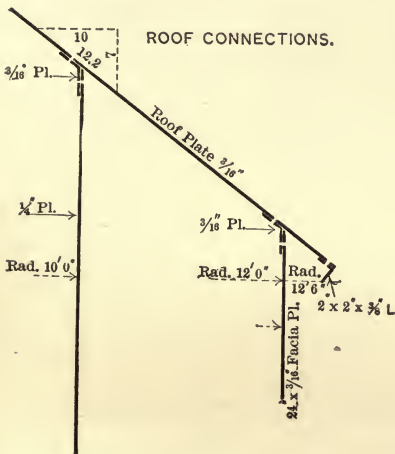

FIG. 54.

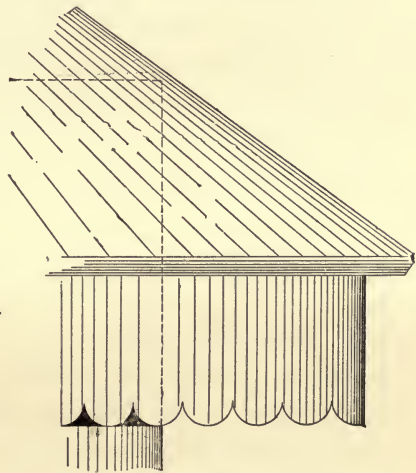

FIG. 55.

practice is to provide some sort of cover, the simplest, and probably the best, being a light steel-plate roof, projecting over the cylinder and terminating with a light circular eaves-angle, forming a conical cover. This design may be elaborated by extending the eaves-angle, back of which may be riveted to a bent plate a steel fascia plate as shown in Figs. 54-55, or omitting the lat-

ter, a galvanized and ornamental cornice may be introduced, riveted to the eaves-angle and tank-plate or as shown in Fig. 52.

For tanks of larger capacities, rafters consisting of steel angles or channels may be specified, spaced to carry a light steel roof, or provided with purlins upon which is laid a wooden roof covered with galvanized steel plate. Such construction permits gables and other architectural features. In the design of the Jacksonville, Fla., water-tower, the cone-shaped roof was surmounted by four gables, and its apex was adorned by an elaborate finial, and in which was introduced an electric-light globe.

With curved rafters a pagoda-shaped roof is formed. This design, while ornamental in detail, is probably no more desirable than the conical roof either in construction or actual appearance.

For ornamentation as well as to stiffen the roof construction, a wooden or gas-pipe flagstaff, commencing at the top of the tank proper, secured by radial ties to its shell and projecting through a bent steel collar plate at the roof apex, is sometimes added, otherwise for tanks of large diameters a vertical rod and radial ties similar to those shown in Fig. 52 should be required.

Trolley-rail.—Some 18 to 24 inches below the circumscribing angle or plate at the top as suitable shape, as a Z bar, should be riveted to the shell to form a rail for a painter's trolley or traveller, and which serves the dual purpose as a convenience and a stiffener to the top of the tank.

Ladder.—If the posts are latticed, the lacing may be used to reach the girder at the top, otherwise along one of the legs, commencing about ten feet from the ground, a light ladder, consisting of, say, two $2'' \times \frac{3}{8}$ bars, connected by $\frac{3}{4}''$ horizontal rungs, spaced 18 to 24 inches should be fastened at intervals of about 10 to 12 feet with steel clips to the post and leading to a 20-inch opening in the balcony floor, extending along the tank shell and terminating at its top. When roofed, a trap opening of about 20 inches and an opening in the roof overhang should be provided. As there is an element of danger in the opening in the

balcony floor, it is sometimes thought desirable to carry the ladder from the top of the post over the gallery rail as shown in Fig. 56.

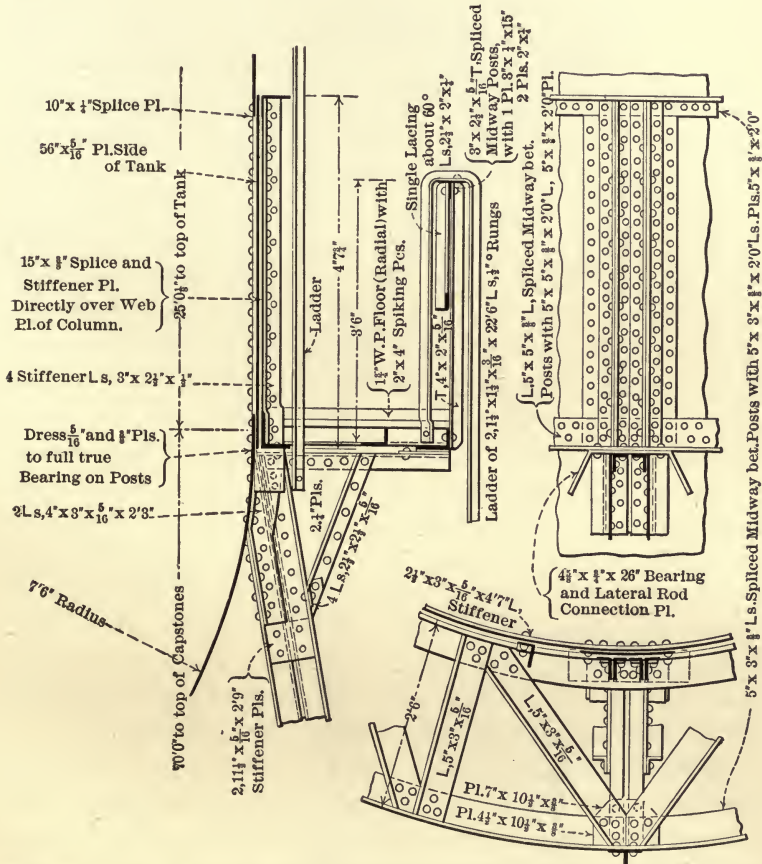

FIG. 56.—Detail of Junction Between Sides and Bottom of Elevated Steel Tanks. (Designed by Prof. A. Marston.)

In cold climates where masses of ice may form inside the tank, the rigid inside ladder should be dispensed with, and in such cases a rope ladder may be used when required.

Balcony.—The necessity for a circumscribing balcony has been discussed and emphasized. Its design permits considerable latitude in the ornamentation of brackets, railing, and other details. While wooden floors are frequently used as shown in Fig. 51 and Fig. 56, a simpler and more durable floor is that made of segmental steel plate, $\frac{1}{4}$ to $\frac{5}{16}$ inch thick, with drain holes as shown in details of Fig. 57. Small and cheap water-towers generally have a gas-pipe post and balcony rails, but the effect is poor and generally unsatisfactory.

Supply Pipe.—Flanged pipe is sometimes specified for the supply main, but the ordinary cast-iron pipe of the bell and spigot type answers every purpose. An expansion joint should be insisted upon, located near the tank connection. Such a joint is shown in Fig. 1. In full hemispherical bottoms, the lower plate is usually formed of dished steel head, and at its lowest point a standard expansion joint should be riveted.

Where the vertical inlet pipe enters the distributing system, a cast-iron foot elbow should be provided, with flat base plate resting upon a masonry pedestal. The lower part of the pipe and elbow should be incased in a circular masonry chamber as a protection and support of a frost case where this is necessary. Where the supply pipe is comparatively small, a water-gate should be inserted at a convenient height above ground and provided with a hand-wheel, otherwise the valve should be placed on the distributing main just outside of the foot bend.

Frost Proofing.—In icy latitudes the supply pipe should be protected from freezing by a frost-case. In extremely cold climates the tank bottom is tapped for a steam-pipe, which is led inside of the case, but ordinarily this detail is omitted, and only wooden boxing or circular laggings, constructed with layers of tar-paper between the sections of lagging, spaced to provide from two to four 2-inch air spaces, is specified. A neater and more durable construction is to make the outer casing of light steel plate, say $\frac{3}{16}$ inch, flanged with light angles and bolted

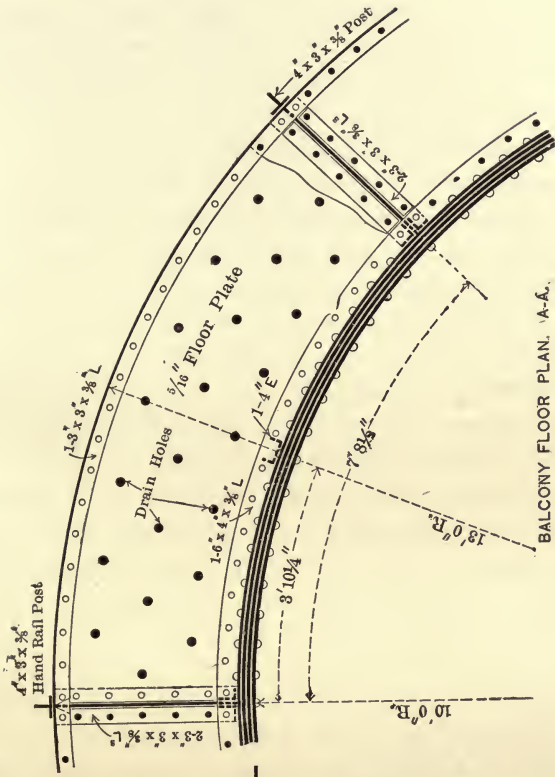

BALCONY FLOOR PLAN. A-A.

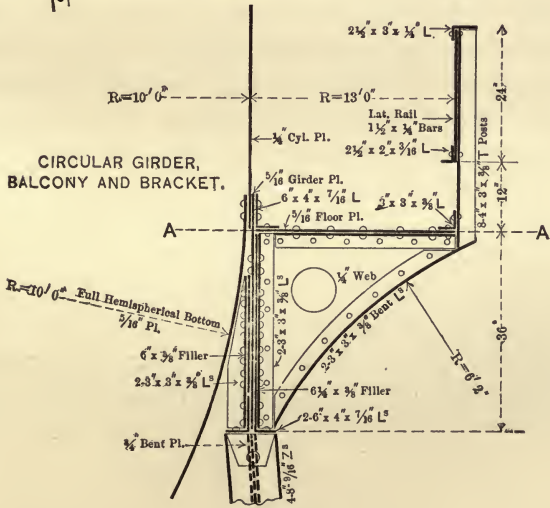

CIRCULAR GIRDER, BALCONY AND BRACKET.

FIG. 57.

in sections of 10 to 12 feet. The supply pipe should be secured in every tower panel by a metal collar, from which radial rods should lead to each post. Where there is little likelihood of frost, the case may be entirely omitted and the supply pipe supported simply by the collar or band and the steel rods.

Connections.—Since nearly all of the large steel companies catalogue and keep in stock Z-bar columns of various sizes, in their publications they also give designs for standard connections, including capitals, pedestals, panel-point and end connections, with bills of material and calculated reactions. The Z-bar column can be so placed that with the four-post tower the connections are square, but when the post is a column built of latticed channels, it is usual to connect the horizontal struts by bent jaw plates riveted to the column.

The connection at the top of posts consists of a bearing plate, reenforced with angles, and the flange of the circular girder is riveted as may be convenient to the bearing plate. In some designs (Fig. 51) the bearing plate is bent and forms a connection for the diagonal rods. The pedestal or footing is generally a steel plate, reenforced also with angles, but often a cast-iron bearing plate or shoe is designed. The thickness of these base plates depend upon the superimposed load and vary from $\frac{1}{2}$ inch to $1\frac{3}{4}$ inches. The other dimensions of the bearing plate at the base must be such as to provide sufficient area for the proper distribution of the weight over the masonry foundations and generally assume at 100 lbs. per square inch of surface upon brick masonry, but a capstone is usually specified. The load which may be allowed upon monolithic piers varies with the texture of the stone and ranges from 15 to 30 tons per square foot. This matter is further discussed in a subsequent chapter, and in which the question of anchorage is also considered. In the ordinary tower the connections are rigid, but in the design of a recently constructed water-tower having a capacity of 150,000 gallons and a vertical height of tower of 200 feet, the bottom of

each footing had an imbedded cast-iron washer $30 \times 12\frac{1}{2}$ inches and 1 inch thick, with a horizontal rib 6 inches deep and 1 inch thick on its under side. Cylindrical nut seats $17\frac{1}{2}$ inches apart were formed in the rib so that two $2\frac{1}{4}$ -inch anchor bolts took bearing at the bottom of the rib and extended through it. One pair of diagonally opposite posts were constructed with sliding seats to allow for temperature movements, while the other two posts were bolted rigidly to the foundations.

Wind-bracing.—The effect of the wind upon the water-tower should be provided for by adjustable diagonals secured to adjacent columns or horizontal struts near their junctions with the columns. The horizontal component of this stress is taken up by the horizontal struts, while the vertical component of the stress is taken up by the tower-posts, and these latter must be added to the loads to which the posts are subjected.

These diagonal brace rods act in tension, dependent upon the force and direction of the wind, each alternate set of rods coming into service at the same time. After erection, the tower when subject to its maximum load may become distorted a little through settlement, therefore the rods should be made in two sections and provided with "swivel" or "clevis" nuts to permit of proper adjustment. The design of the rod-connection will depend upon the section of column or strut selected, but where possible, the rod should be bent and welded to form an "eye" for which a "pin-connection" may be provided. This style of wind-bracing is in general use on account of its simplicity and economy, but in the lower tower panel, where a diagonal rod might under certain cases prove objectionable, a type called "portal-bracing" might be employed. A most massive, ornamental, and effective example of this type is seen in the lower panel of the Eiffel tower, of Paris. Its general lack of utility for water-towers prevents its more frequent use, although its adoption offers considerable scope for architectural and ornamental effect.

Anchorage.—The force of the wind acting upon the diametral plane of the tank and the exposed tower surfaces is exerted over

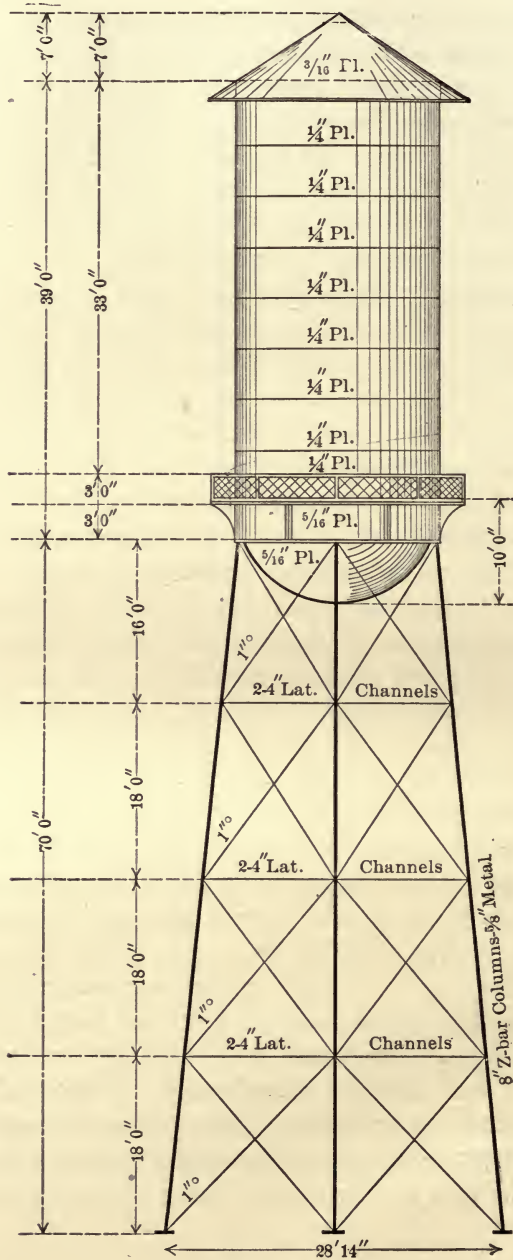

FIG. 58.

a leverage which for practical purposes may be considered as being equal to the height of the tower and half of the tank, and produces the overturning moment of the structure, which must be resisted by the weight of the metal, acting through a lever arm equal to the horizontal distance from the centre of the figure at its base to an axis about the outer lines of the base. When the forces are not in equilibrium, anchorage must be provided consisting in general of steel rods, two usually to each tower leg, with nuts at each end and provided with a cast-iron washer to be buried in the masonry pier.

Graphic Diagram.—The capacity of the tank, the height of the tower, and other general features having been considered and decided upon, a diagram similar to that shown in Fig. 49 may be drawn to any convenient scale and its principal dimensions first indicated. The theoretical thickness of the cylinder plate, web girder, and tank bottom are next to be found from formulas or tables given heretofore, after which the details of the cover and balcony should be determined, illustrations of which have been heretofore shown, and from all of which the gravity loads may be approximately calculated and the resulting stresses to which the circular girder and the supporting columns are subjected can be closely determined either analytically or graphically, as may be preferred, and their members properly proportioned. Fig. 59 shows a stress diagram of the loads for a four-post tower of dimensions as indicated in the diagram (Fig. 58).

Estimating Quantities.—Using these dimensions and proceeding according to the formulas given in a previous chapter, capacities, areas, and quantities may be obtained as follows:

Dimensions and Capacities.	Gals.	Pounds.
Cyl. 20×39 ft. capacity = $5\frac{1}{3}D^2A$	91,369	
20 ft. dia. hem. bottom, capacity = $1.96D^3$	15,680	
Total capacity in gallons.	107,049	
Cyl. 20×39 ft. capacity, $49.1D^2A$		765,960
20 ft. dia. hem. bottom capacity, $16.36D^3$		130,880
Weight of water, total pounds.		896,840

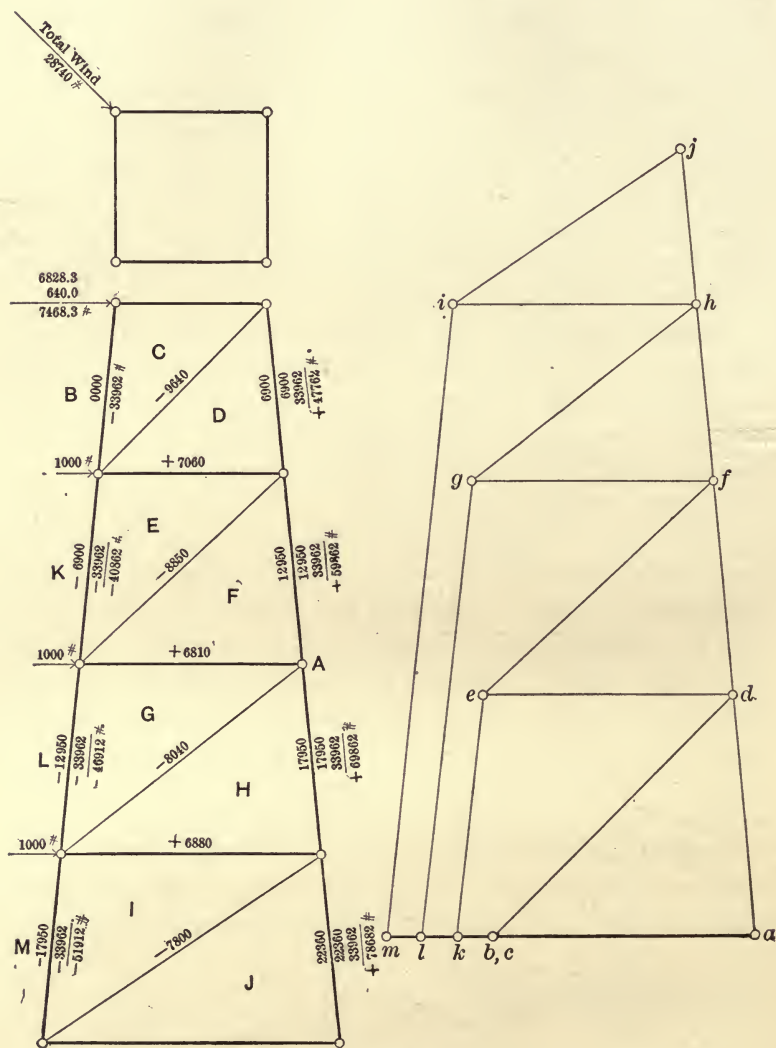

FIG. 59.

SURFACES, AREAS, AND WEIGHTS.

Dimensions and Capacities.	Pounds.
Cyl. $\frac{1}{4}$ in. pl., $\pi DA \times 10.2$	24,990
5/16-in. cir. girder, $\pi DA \times 12.75$	2,405
5/16 bot. pl., $\frac{1}{2}\pi D^2 \times 12.76$	8,017
3/16 con. cover, $\frac{1}{2}\pi DA$, sec. $\theta \times 7.66$	4,144
3/16 facia pl. and angles, 289×7.66	2,214
Eaves angle, 78.5×4.7	369
5/16 pl. floor, 3 ft. wide, 2168×12.75	2,764
8 brackets.	1,520
37-ft. ladder.	242
3-ft. Z trolley	422
Weight of metal.	47,087
10% allowance for overweight.	4,708
Total weight of metal.	51,795
Weight of water.	896,840
Total weight of tank and contents.	948,635

In addition to the above, allowance must be made for the laps of plate; for the weight of the rivets, and that of the necessary flange angles and stiffeners of the circular girder and to be exactly determined later, but approximated as follows:

Laps.	3,000
Rivets.	4,500
Angles and stiffeners.	2,500
Approximated.	10,000

Stress in the Girder.—The total weights as found above being taken as 958,000 lbs. must be supported by the circular girder, and in this case upon four points of support.

From formula previously given, the bending moment of the girder at the point of support where four columns are used is found to be $0.03414Wr$, where W is the whole weight and r the radius of the tank in inches; substituting, the bending moment is

$$0.03414 \times 958,000 \times 120 = 3,270,612 \text{ inch-pounds.}$$

This stress must be overcome by the resistance offered by the girder section, whose unit stress and modulus must be found.

In the discussion of the girder, Carnegie's formula for shear strains was given, but ordinarily it is usual to take 10,000 lbs. per square inch of metal as an allowable unit stress, as it is considered good practice to allow flange strains of 15,000 lbs. per square inch and as much as 11,000 lbs. of net section for the vertical shear of the web. The modulus of resistance, R , of a shape being its moment of inertia, I , divided by c , the depth of its neutral axis, the safe resistance moment is $R \times S$, or modulus multiplied by the unit stress.

The web of the girder having been previously found, the other elements must be obtained by trial.

Deciding upon one top and two bottom flange angles of dimensions and placed as shown in Fig. 48, their elementary areas, a , would be as follows:

	Area.
2 bottom angles, $6 \times 4 \times 7/16$	8.42
$5/16$ -in. \times 36-in. web	11.25
Top angle, $6 \times 4 \times 7/16$	<u>4.21</u>
Total section area, or $\Sigma a = A =$	23.88

The distance, z , from an axis to the centre of gravity of each elementary area must next be found. The various handbooks give this for numerous shapes, some one of which can generally be used; otherwise special calculation is necessary. The quantity given must be taken from the length of the lever arm of the compound shape as measured from an axis at one end of the web, or in other words, from the depth of the girder; in this case from 36 inches. The elementary areas, in the present case, multiplied by their leverage is found to be

$$8.42 \times 34.03 + 11.25 \times 18 + 4.21 \times 4.03 = 506.8,$$

which divided by the area of the whole shape $A, = 23.88$, gives the neutral axis of the girder,

$$c = \frac{506.8}{23.88} = 21.2 \text{ inches;}$$

and the moment of inertia,

$$I, = 8.36 \times 21.2^2 + 6.62 \times 21.2^2 + 4.62 \times 1.48^2 + 4.18 \times 14.8^2 = 8658.2;$$

the modulus of rupture is

$$R = \frac{I}{c}, \text{ or } \frac{8658.2}{21.2} = 408.4,$$

and the safe resisting moment,

$$R \times S = 408.4 \times 10,000 = 4,084,000 \text{ inch-pounds,}$$

and to withstand a maximum bending moment at the post of 3,270,612 foot-pounds.

An angle with dimensions $6 \times 4 \times \frac{3}{8}$ would have been closer to the requirements, but the difference in weight is small, and since the circular girder also sustains, in this case, a small wind stress beside and is the most important member of the structure, the $1/16$ thicker angle will be retained, and it is also well to reenforce the girder with stiffening angles over the point of support as shown in Figs. 51, 56, 57.

Wind Stress in the Girder.—The wind stress in the girder is produced by the action of the wind upon the sides, and is usually considered as being exerted upon the diametral plane of the cylinder and acting as a cantilever beam, the formula for

which has heretofore been given as extreme fibre stress $S = \frac{9.55A^2}{rt}$,

where A = height of cylinder;

r = its radius in inches;

t = the thickness of the shell.

This stress is considerable in large structures such as stand-pipes of considerable dimensions, but in the usual water-tower it need hardly be considered. With the 20×42-ft. tank under consideration, this stress is less than 500 lbs. per square inch of metal.

Torsion Moment.—The maximum torsion moment of the girder for 4 points of support is found to occur at an angular distance of $19^{\circ} 12'$ from the point of support, or in the case under consideration, 3.35 feet along the girder, and this stress can be determined from the formula given, viz., $0.0053Wr$. Ordinarily this stress need not be considered for tanks of the usual capacities.

Horizontal Reaction at the Top of Posts.—The total weight being estimated as 958,000 lbs., the vertical load, W , at each point of support of a four-column tower is 239,500 lbs., and where the angle of inclination of the post is $\theta = 7^{\circ} 59'$, whose tangent is 0.14, the horizontal reaction H , according to the formula given $= W \tan \theta$ or 33,530 lbs.

As with the gravity load, there is also a horizontal reaction from the assumed wind stress, found by graphical analysis (Fig. 59) to be 7468 lbs., or a total horizontal thrust at the top of each post of 40,998 lbs.; where $r = 120$ inches, from the formula and table, the maximum bending moment at each point of support is $M = 0.137$, $Hr = 674,000$ inch-pounds, and to resist which the ring forming the horizontal flange of the circular girder may be used. Its elements, from the details of Fig. 57, are found to be, moment of inertia, $I = 3847$; distance from neutral axis, $c = 4.03$ inches, and modulus of rupture, $R = 954.5$. Assuming a unit stress S , the safe resistance moment of the shape, $= R \times S = 954,500$ inch-pounds as against a maximum bending moment found to be 674,000 inch-pounds; hence the flange ring as designed is well within the limit of safety to resist this reaction. In large structures, however, where the posts have considerable inclination, the flange ring is often found insufficient

alone to resist this stress without considerable additional metal, and in such cases it may be necessary to employ a continuous curved girder in the horizontal plane.

Overtuning Moments at Points of Support.—The overturning moment of the tank at its points of support must be resisted by the connections of the tank to the tower where the weight of the empty structure is insufficient to produce stability of position, but in general it is always considered necessary to rivet the flange of the girder to the top of the posts.

Where P = total wind pressure;

G = distance in feet from top of post to centre of gravity;

M = overturning moment in foot-pounds.

From the formula given, $M = PG$; substituting the values from the diagram (Fig. 58),

$$P = 958 \times 30 = 28,740 \quad \text{and} \quad G = \frac{3.1 + 33.7 + 10}{2} = 23.4 \text{ feet;}$$

$$M = 672,516 \text{ foot-pounds.}$$

With the assumption that the direction of the wind is in the direction of a diagonal in the horizontal plane of the figure formed by the posts, the tank would tend to overturning about an axis at the leeward post, and is resisted therefrom by the weight of the tank metal multiplied by its leverage, or in this case, by the radius of the tank; then $M = 61,795 \times 10 = 617,950$ foot-pounds.

Assuming 10,000 lbs. per square inch of rivet metal as a safe value, each square inch of metal would have a holding-down value of 100,000 foot-pounds; hence 4 rivets, 7/16-inch diameter, providing an area of 0.61 square inch, would prove sufficient to establish equilibrium; however, it is usual to make these connections of considerably larger diameter, usually 1-inch rivets being employed and driven at such points as may be convenient structurally.

Tension on the Joint between the Bottom and the Cylinder.

—When, as in the case under discussion (Fig. 48), the bottom is a hemisphere, the stress along this joint is

$$\frac{W}{2\pi r}, \text{ or } \frac{904,857}{754} = 1200 \text{ lbs. per linear inch.}$$

For $5/16$ -inch bottom plate, with $3/4$ -inch rivets, having 70% efficiency of joint, the strength of this connection is

$$\frac{0.3125 \times 60,000 \times 70\%}{4}, \text{ or } 3491 \text{ lbs.};$$

hence the plate assumed and rivets given are ample to resist the stress along this joint.

The hemispherical bottom may be composed of one circular dished head of steel plate, say 96 inches in diameter and $5/16$

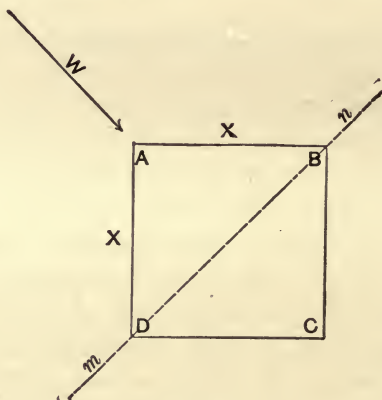

FIG. A.

inch thick, with ten $5/16$ -inch curved special plates, all $3/4$ inch double riveted along the vertical joints, or the segments may be made of such size as may be structurally economical. The

supply pipe, of required diameter, should be connected to the bottom at its lowest point by means of a standard expansion-joint.

Stress and Section of Tower Members.—The determination of the stress produced in the tower by the action of the wind is arrived at as follows:

Taking wind in direction of the diagonal as shown by arrow W (Fig. A), the maximum tension is produced in column A and the maximum compression in C ; therefore, taking moments about mn , WH or $M = V_a X \sin 45^\circ + V_c X \sin 45^\circ$; and as $V_a = V_c$, therefore

$$V_a = \frac{M}{2X \sin 45^\circ} = .707 \frac{M}{X}.$$

This vertical force (V_a) is resolved into its components, a force downward through the columns and the horizontal force, which is in turn resolved into two forces lying in the planes of the trusses AB and AD . The same is true of V_c at column C , hence tension in A is $S = V_a \sec \theta$, θ being angle of inclination of post. Compression in C is the same as tension in A .

The horizontal force then is $h = V_a \tan \theta$, and its components in the sides of the tower marked R (Fig. B) are

$$\begin{aligned} R &= h \sin 45^\circ, \\ R &= V_a \tan \theta (.707). \end{aligned}$$

Having the shear at the top of each post, which is $\frac{W}{4}$, acting in the same direction as the wind, this must be resolved into forces lying in the planes of the sides of the tower. These are equal to $P = \frac{W}{4} \sin 45^\circ = \frac{W}{4} (.707)$ acting in direction shown by arrows P (Fig. C).

These forces must be combined with the forces R , and this combination is shown in Fig. D.

Each side of the tower may now be analyzed graphically, giving the stresses in the struts and bracing and additional stress

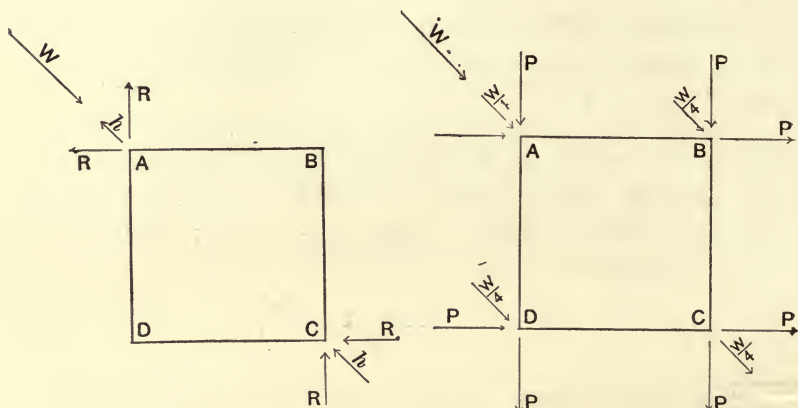

FIG. B.

FIG. C.

in columns; these must be combined algebraically with the stresses already found in them to obtain the maximum.

Solution.

$$M = 28,740 \times 23.4 = 672,516 \text{ ft.-lbs.};$$

$$V_a = \frac{.707 \times 672,516}{14.14} = 33,625.8 \text{ lbs.};$$

$$S_c = S_o = V_a \sec \theta;$$

$$\sec \theta = 1.01;$$

$$\theta = 7^\circ .59';$$

$$\tan \theta = 0.14;$$

then

$$S = 33,625.8 \times 1.01 = 33,962.06;$$

$$R = V_a \tan (\theta) .707$$

$$= 33,625.8 \times 0.14 \times .707 = 3331.28;$$

$$P = \frac{W}{4} (.707) = 5079.79.$$

The wind stresses having been determined as explained and indicated on a diagram as shown in Fig. E, the loads due to the weights must be considered and combined.

The vertical gravity load at the top having been estimated at 958,000 lbs. for the four-post tower, the weight at the top of each column is 239,500 lbs.

The vertical reaction of this load through each post is $\frac{W}{4} \sin \theta$, or $239,500 \times 1.01$. This stress is compression and must be combined with the maximum compression at the foot of the column

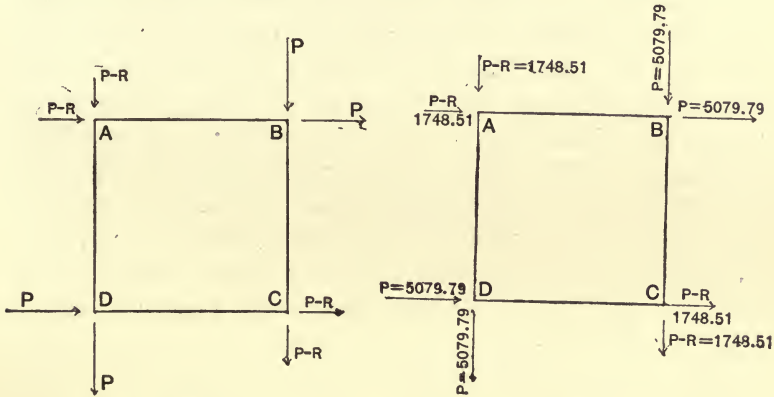

FIG. D.

FIG. E.

and produced by the wind, graphically found to be 78,682 lbs.; hence the maximum compression from the combined gravity and wind stress and exclusive of the weight of the post itself and dependent tower members is 318,182 lbs., or 159 tons. It is generally considered good practice to limit the length of any section of main posts to 100 times its least radius of gyration, and in such case an 8-inch rectangular column, whose radius of gyration is $r = 2.31 (r^2 = \frac{1}{12} d^2)$, might be used in length as great as 23 feet. Having determined upon 18 feet as the longest section of the tower column, $\frac{l}{r} = 7.7$, and from the table according to the Gordon formula, by interpolation, the ultimate strength for such length is taken as 32,220 lbs.; with a factor of safety

of 5 for tower members, the safe unit stress is 6,444 lbs. per square inch, and the metal required for the column section would be $\frac{318,182}{6444} = 49.4$ square inches, and which may be secured by a pair of laced channels or other suitable combination of shapes.

Determining to use a Z-bar column, according to Carnegie's handbook, a standard $\frac{5}{8}$ -inch column has 26.3 square inches, weighs 84.1 lbs. per foot of length, and its minimum radius of gyration is given as 2.58, and its safe bearing for lengths of 18 feet and under as 157.5 tons. Since this is the nearest section to safely support the given load, it will be selected. With a vertical height of 70 feet, the inclination of the tower will increase the length of the column beyond 70 feet, but the extra length may be neglected in determining the approximate weights. Similarly the load of each pannel exerts a horizontal stress which should be combined with that found graphically for the compression stress due to the action of the wind, but these loads being small, will also be omitted. The exact lengths of the horizontal and diagonal members of the tower truss are hardly ever calculated except in shop details, but are usually scaled from the diagram as being closely approximate. In the case under consideration, it will be seen from the diagram that the set of diagonal rods at the top of the tower are subjected to the greatest stress, shown as 9640 lbs. tension. With an allowable unit strength of 12,000 per

square inch of rod metal, the required area is $\frac{9640}{12,000} = 0.8$ square inch, or about 1 inch round rod, which may be adopted for all of the diagonals in this case. The first horizontal member from the top being in compression 7060 lbs. and its length being 23 feet, its section must be determined. Commonly two channels or four angles, riveted back to back, are used for such members. Selecting a pair of 4-inch channels, weighing 5.25 lbs. per lineal foot, from Carnegie's handbook, their least radius of gyration for neutral axis perpendicular to their web at centre is given

as 1.56, then $\frac{l}{r} = \frac{23}{1.56} = 14.7$, and from the table (Gordon's formula) their ultimate strength is approximately 21,320 lbs.; their permissible unit strength therefore is $\frac{21,320}{5} = 4265$ lbs.; then the area of the metal in the section required would be $\frac{7068}{4265} = 1.65$ square inches; the area of section for each of the assumed channels is given as 1.55, hence for the two the combined area is 3.10, which is greater than required, but since it is economical constructurally to make all sections as near alike as possible, when differences are small, the same size section may be employed throughout in each of the pannels. The lower horizontal member having a length of 30 feet and its radius of gyration being the same (1.56), its length, divided by its least radius of gyration = 19.3, which from the table gives an ultimate strength of approximately 16,170 lbs., and dividing by 5, = 3234 lbs. permissible unit stress; the area of the metal required is $\frac{6880}{3234} = 2.1$, and since the pair of channels selected have an area of 3.1, they would be satisfactory throughout for compression members. Scaling the lengths and multiplying by the unit weights of rods, channels, and main post, the additional weight at the foot of the column is found to be 7075 lbs. Neglecting the slightly increased stress which would be found by multiplying this weight by the secant of the angle, and adding the weight directly, the total compression in the lower section of the column is 325,257 lbs., or 162.6 tons.

When a horizontal strut or tie is used at the base of the tower, its weight must also be included.

The horizontal reaction H at the foot of the post = $W \tan \theta$, or $325,257 \times 0.14 = 45,536$ lbs.

The stress in each tie is $\frac{H}{2} \sec \beta$, or in this square tower frame

$22,768 \times 1.41 = 32,103$ lbs. For the tension in this connection and allowing 10,000 lbs. per square inch, the section area = 3.2 inches.

In smaller tower designs, the tie at the base of the tower is frequently omitted, but in which case the horizontal thrust H of the weight must be resisted by the direct shear on the anchor-bolts and the friction of the shoe on the masonry pier. There is then produced an overturning moment on the foundations which must be provided for in foundation design, in order that the resultant of the loads will come in the centre of the bearing surface and avoid unequal settlement of the foundations.

Bearing-plate.—The thickness of the bearing-plate when made of steel, with an allowable shear value of 12,000 lbs. per square inch to sustain safely the imposed load of 325,257 lbs. applied by a column section of 26.3 square-inch area, = $\frac{325,257}{26.3}$

$$= \frac{12,367}{12,000} = 1 \text{ square inch.}$$

The other dimensions of the bearing-plate must be such as to provide sufficient area to properly distribute the load over the masonry foundation.

A stone sill or cap is generally provided, surmounting the pier and directly supporting the bearing-plate. The unit load which it is considered good practice to allow upon a monolithic capstone is taken at from 15 to 30 tons per square foot of bearing, depending upon the character of the stone used. Assuming

20 tons per square foot as a reasonable average, $\frac{325,257}{40,000} = 8$ square feet, or $\sqrt{1152} = 34 \times 34$ inch plate required.

Stability of Structure and Anchorage.—Investigating the stability of the structure upon the principle previously explained, with the direction of the wind normal to the side of the square formed by the tower frame, the tendency would be to overturn about the base of the two leeward columns, and this must be

resisted by anchorage where the resisting moment is less than the overturning moment. In general it is considered good policy always to provide anchorage, and to design same by considering the weight only of the empty structure, as the maximum wind stress may occur at a time when the water has been withdrawn from the tank.

The usual anchorage consists of rods with washer and nuts, the former buried in the masonry and the latter screwed down upon the bearing-plate, through which and the capstone the rods project through holes drilled to templet. As has been explained, if the tie at the foot of the tower is omitted, the horizontal thrust produced by the weight will be resisted by the shear on the anchor rods, and this must be considered in such cases and the dimensions of the rods fixed accordingly.

CHAPTER X.

FOUNDATIONS.

THE generic term, Foundations, comprehends both the soil and the materials upon which a structure is designed to rest; the line of demarcation or termination of the foundations and commencement of the substructure is variable, but in general the approximate ground-line is the limiting point. More exactly, every foundation may be regarded as having two components—the bearing-soil, or subfoundation, and the foundations proper, consisting of the materials intended to form a solid base for the superstructure.

The preparation of the natural soil for suitable sub-foundations demands as wide a consideration and treatment as the wide difference of geological conditions, but in practice an intimate knowledge of the varying soil characteristics is not possible or hardly necessary, and it is considered sufficient to contrast the given soil with one or more of the more common formations whose qualities are determined from long experience. Such typical formations are rock, clay, gravel and sand, and alluvial soils.

Rock.—Discussing these in the order named, the best natural subfoundation is rock, in classification varying from the crystalline types to soft-deposit specimens, easily water-worn or subject to atmospheric disintegration, for experience has shown that any stone formation, well bedded, will safely sustain any load that may be imposed upon it by any masonry foundation, even for the largest structures.

Frequently the stone is not found in horizontal, continuous layers, but in seamy strata, offering a bearing-surface of more or less irregularity and composition. For the suitable preparation of such a subfoundation the overlying earthy matter and any decomposed or decayed stone must be removed to "bed-rock" or the solid layer, which is then blasted or sledged to a surface as nearly perpendicular to the pressure to be imposed as possible. Interstices or fissures of the rock should be filled with broken stone or concrete, and where the bearing will not be entirely upon stone, but upon contiguous earth, at such junction especial care should be taken to thoroughly compact the softer material or to remove it altogether, substituting broken stone, or preferably concrete, bedded as well as possible to the more unyielding natural stone by cutting the bed-stone in steps, or making some other effective union; otherwise unequal settlement, the result of unequal resistance, will result.

Clay.—Clay, when dry and likely to remain so, is an ordinary and excellent foundation, being easily excavated and having a safe bearing-value for ordinary structures; but clay is a treacherous material in that it so readily absorbs moisture, its seamy veins acting often as conduits for underground streams of varying magnitude. When clay absorbs water, its tendency is to swell and soften, and under such conditions, when confined, it exerts a material pressure upon the sides or bottoms of foundations, tending to bulge and crack them. When unconfined it spreads in every direction, oozing and squeezing from under the weight imposed and becoming unstable and uncertain in action. Exposed to the moisture of the air it becomes more or less saturated, and at low temperatures the mass freezes, expands, and disintegrates after a thaw, proving a most intractable material. From this fact, in preparing the subfoundations in such material, the excavations should extend well below the frost-line, and the ex-

posure of the foundation-pit to atmospheric influences should be as limited as possible, as a sudden rain may change a good foundation to a quagmire. Excavations in clay should be made immediately in advance of the actual masonry construction.

When wet, the bearing value of clay can be artificially increased and improved by incorporating with it, according to its plasticity, layers of sand or gravel, or both, or by spreading layers of concrete.

The tendency of the veins of the clay to transport water results in the discovery of springs of water of more or less volume in a number of foundation-pits, and these springs are a source of embarrassment and trouble, as they prevent the masonry from setting, or ooze or stream through the sides or bottom of the completed work.

Their treatment is largely a matter of personal experience, but the less troublesome varieties may be suppressed by plugging the water-bearing crevice with dry sand and cement, dry cement or concrete, either directly or upon some fibrous material, such as yarn, which will absorb the moisture until the cement has an opportunity to set, or upon some impervious material, such as tarred or oiled cloth; or by setting a tube over the aperture, and plastering about its foot with pipe-clay, or some plastic material, allowing the water to rise in the tube, or be drawn away through the tube while the masonry is being constructed. After the masonry has set the tube may be plugged with concrete below the face of the foundation, and then either cut off or withdrawn. These are only general suggestions, experience being the only safe guide in such emergencies.

Dry Sand.—Dry sand makes one of the best subfoundations if its status as such can be fully determined, for it is an almost incompressible body; is not affected by exposure to any extent, and its bearing power is therefore very great.

The size of the grains of sand may increase from very fine particles to coarse gravel; the coarser the grain, the better the foundation as a rule. Gravel and sand, when incorporated with a binder of clay, are cemented together to an extent which makes such a soil but little less valuable as a bearing material to the softer grades of rock, but where the grains of sand are fine, having no cohesion, the mass, when saturated with water, becomes semi-fluid, and is subject to hydraulic principles. Owing to its porosity and susceptibility to moisture, sand, like clay, is subject to the disintegrating effects of frost, and the foundation-pits should therefore be excavated below the liability of such exposure. Also like clay, having a capillary attraction for fluids, in sand foundations, springs are frequently encountered which should be treated as above suggested in the absence of more definite knowledge and experience. The same methods would apply for a weak clay foundation, such as spreading concrete over the area uncovered, is advisable to assist and to augment its bearing-surface, but frequently in such soils, as well as upon the clay variety, the bearing values are increased by removing a portion of the soft material and driving or jetting down short piles upon which stringers of wood are spiked, the spaces between rows being filled with concrete; sometimes the use of the stringers alone will be found sufficient in addition to the use of the concrete, which is compacted flush with the tops of the sills. Such construction is called "grillage," and is frequently used. Since timbers covered by water and removed from atmospheric oxidation have been proven to last for indefinite periods, such a foundation, where completely subject to saturation, is very effective and safe. In very soft sand, clay, or alluvial soils these methods are found effective, and in addition planking, making a floor for the foundations to be started upon, is spiked transversely

upon the tops of the stringers and over the concrete deposited between them.

Quicksand.—When sand is so completely saturated as to become fluid, it is termed “quicksand”; it has no peculiar qualities or inherent properties, but is generally given an individual classification.

Any saturated sand is “quick” when the upward pressures of the underground waters are sufficient to overcome the tendency of gravity to keep its particles at rest. Sand of coarse grains resists this upward tendency to a greater extent than the finer varieties; hence quicksand is usually a very fine grained sand, and from the fact that it must be found immersed in water, the constant friction of its particles moving upon each other grinds the sharp points and angles, until the grain becomes rounded or “water-worn,” the usual condition of the grains of the so-called quicksand.

Increasing Bearing Values.—In very soft material, where the necessity of reenforcing the bearing-value of the soil is apparent, and where there exists an underlying soil of better material, the piles, when driven through the top soil, penetrating into the strata below, act as so many columns whose ultimate bearing is the crushing strength of the material of which the pile consists, but where there is no such lower soil the piles are supported in the soft material only by the friction of that material against their sides, and the determination of their safe bearing-value is more problematical. Rankine gives as a rule for the safe bearing of piles under this last condition the area of the head of the pile in inches by 200; thus a 12-in. pile, having an area of head of 78 sq. in., would give a safe bearing of 7.8 tons.

A simple rule frequently used for the safe bearing value of piles is one formulated by Major Sanders, of the U. S. Engineer Corps, from experiments made with common wooden piles at Ft. Delaware, and is as follows:

$$\text{Safe load in lbs.} = \frac{\text{Weight of hammer in lbs.} \times \text{fall in inches.}}{8 \times \text{penetration at last blow}}$$

Applying this rule to a pipe driven with a 2240-lb. hammer and penetrating, under a 20-ft. drop, 1 inch, the safe bearing in tons is found to be 33.6.

This value would probably be considered too high.

A formula in very general use is one given by Trautwine, and is used with a factor of safety varying from one-half to twelve, depending upon local conditions. This rule is

$$\text{Extreme load in tons} \left\{ = \frac{\text{Cu. rt. of fall in ft.} \times \text{wt. of hammer in lbs.} \times 0.023}{\text{Last sinking in inches} + 1}$$

Taking the same constants as above, the *extreme* load is 128.9 tons. Using a factor of four, the result is about as given under the Sanders formula. Usually from 18 to 20 tons is considered a proper load for a 12-inch pile.

In piles supported by the friction along their sides, the ultimate value of that friction is estimated at from .2 to 1 ton per square foot of bearing for each foot of length, depending upon the soil characteristics. In silt or wet river-mud, when driven three feet apart, the possible value of friction upon unbarked piles is .5 tons per foot length. In New Orleans, where the soil is a saturated alluvial for 900 feet depth, piling is used for all building foundations where much weight is to be imposed. In some of the larger buildings, even with this addition to the bearing-values, considerable settlement has been observed. A foundation designed for a stand-pipe, 13 × 100 ft., in that locality, consisted of 100 piles, driven an average of 60 ft. deep, and spaced 2 ft. in both directions. The piles were of unbarked cypress, aver-

aging .5 cu. ft. per foot length. Although continuing to penetrate under the blows of the hammer considerably more than $\frac{1}{2}$ in., the piling was stopped at 60 ft., upon the theory that the frictional resistance through that depth would equal .5 ton per foot of pile length or 3000 tons for the 100 piles. Assuming a factor of safety of 5, the safe bearing was determined at 600 tons, which represented the total weight of the tank, water, wind-stresses, and foundations.

No observable settlement in this foundation has taken place in several years. The piles were sawn and capped; the longitudinal spaces were filled with concrete flush to the top of stringers, and the grillage floored, all timber being below the point of saturation of the soil. All earth foundations must yield somewhat, but this is not important in the case of isolated structures such as stand-pipes and the like, provided the settlement is gradual and uniform, and not of radical extent.

The following table represents the safe values of ordinary soils according to Prof. Ira O. Baker:

SAFE BEARING-VALUE OF SOILS.

Kind of Material.	Safe Bearing-power in tons per sq. ft.	
	Max.	Min.
Rock, the hardest, in thick layers, in native bed.....	..	200
“ the softest, easily worn by water or exposure to the weather.....	..	18
Clay, in thick beds, always dry.....	6	4
“ “ “ “ moderately dry.....	4	2
“ soft beds.....	2	1
Gravel and coarse sand, well cemented.....	10	8
Sand, compact and well cemented.....	6	4
“ clean and dry.....	4	2
Quicksand and alluvial soils.....	1	0.5

Stone Masonry.—The requirements for a serviceable foundation building stone are, in the main, that it shall be

hard, tough, close-grained and durable. Upon its closeness of grain and non-porosity depend its non-absorbent properties, without which the stone is likely to disintegrate along its layers. A stone with a granular texture is likely to crumble in weathering to a greater extent than one with a crystalline formation. Before determining upon a building stone, and where a choice is possible, investigation as to its possible usefulness for the particular service required should be made by an examination of the effects of exposure and service upon like stone in any old structure, or by an examination of the quarry, where the effects of weathering and decomposition should be carefully observed, noting whether the stone has disintegrated to an appreciable extent, or has corroded, or whether the old lines of fracture remain sharp and fresh. Where a new quarry is to be opened, and there is any doubt as to the character of the stone, it should be subjected to artificial tests such as crushing, abrasion, etc.

The more common and serviceable building stones are granite, limestone and sandstone, in their several varieties. The cost of quarrying such stone will depend upon such factors as the wages of the quarrymen, the mechanical facilities for such work, as well as the amount of "stripping" necessary, and other items likely to affect their cost. Roughly, stone can be quarried at from 40 to 80 cts. per cubic yard, varying in different localities and unlike conditions.

Stone masonry is of various classes, but for such foundation work as the foundations for stand-pipes, it may be assumed that it will be either ashlar, range rubble, or rubble, laid in cement-mortar.

Ashlar is the highest grade of masonry; it is squared dimension-stone, cut with varying degrees of nicety, and is consequently considered as first class, second class, etc., owing to the finish required.

Owing to the care necessary for its preparation, it would

hardly be employed, owing to its cost, upon any portion of a foundation for a stand-pipe except possibly the first course immediately below the superstructure, where such course is exposed. Frequently the cut stone is used only as a belt upon the outer perimeter of the foundations, the interior or core being "backed up" with rough rubble masonry, well flushed and levelled with cement. This last type of masonry consists of rubble proper and range rubble masonry; the former being stone of almost any dimension, roughly sledged for use, and bedded in cement without regard to horizontal jointing; range rubble requires that the stone shall be laid to a rough line horizontally; the first of these distinctions of rubble masonry is generally used below the ground-line and for the core of the foundations, while the range rubble is employed for the exposed surfaces up to the first course under the structure, which is frequently of ashlar finish. As with the quarrying, the local conditions modify the cost of all masonry work, but roughly the following will give an idea of the relative value of several masonry classifications:

First-class ashlar	\$12.00 to \$15.00	C. Y.
Coursed rubble	4.00 "	6.00 "
Rough rubble	3.00 "	5.00 "
Concrete—1 part Port. cement, 2 sand, 4 broken stone	4.00 "	6.00 "
Ordinary brick masonry—cement mortar	5.00 "	8.00 "

In stone masonry, Rankine's general rule, modified to suit particular conditions and individual ideas, is largely used and is as follows:

RANKINE'S RULE.

I. Build the masonry as far as possible in a series of courses, perpendicular, or as nearly so as possible, to the

direction of the pressure which they have to bear; and by breaking joints avoid all long continuous joints parallel to that pressure.

II. Use the largest stones for the foundation course.

III. Lay all stones which consist of layers in such manner that the principal pressure which they may have to bear shall act in a direction perpendicular, or as nearly as possible, to the direction of the layers. This is called *laying the stone on its natural bed*, and is of primary importance for strength and durability.

IV. Moisten the surface of dry and porous stones before bedding them, in order that the mortar may not be dried too fast and reduced to powder by the stone absorbing its moisture.

V. Fill all parts of every joint, and all spaces between the stones, with mortar, taking care at the same time that such spaces shall be as small as possible."

From various authorities the following table has been compiled :

SAFE BEARING-VALUE OF MASONRY AND MODULUS OF RUPTURE OF MATERIALS.

	Mod. of Rupture per Sq. In.	Crushing Strength per Sq. Ft., in Tons.
Granite.....	1800	75
Limestone, common varieties.....	1500	62.5
Oolitic limestone.....	2338	17.5
Sandstone (brownstone).....	2160	60.0
Concrete, 1 month, 1 part Port. cement, 2 parts sand, and 4 parts broken stone..	150	7.0
Brick laid in Port. cement, 1 to 2 mortar...	800	10.0
" " " Rose'le " 1 to 2 mortar..	800	8.0

Brick Masonry.—There is no generally recognized manufacturers' standard brick, the general character and dimensions varying considerably in different localities, but an average size is $8\frac{1}{2}'' \times 4'' \times 2\frac{1}{2}''$; such brick, when dry, will weigh about 5 pounds each, and in rough reckoning 500 such brick are

estimated as making a cubic yard of masonry, which weighs approximately 1.2 tons. With such brick an ordinary mason, with one helper, will lay 2000 in foundations. In such work, below the surface, the brick can be rapidly placed in courses and then grouted in by "slushing" cement-mortar over the surface, which fills the interstices and makes a bed for the succeeding course; in such foundations bats may be used in moderate numbers. At the ground-line more care is taken, and the brick are laid to a horizontal line, those forming the face being carefully laid, and the mortar-joints, which should not be over $\frac{1}{4}$ in. thick, are "struck" and neatly pointed. A good foundation-brick should be of close clay texture, well made, hard, and carefully burned. When two such brick are struck smartly together they should give a clear, metallic ring. Foundation-brick should not absorb more than about 7 per cent. of their weight of water after immersion for 24 hours. The color of a brick is no index of its qualities, although where the clay soil contains oxide of iron the color of the brick after burning will be red, and a good foundation-brick will be a "cherry-red." Obviously, the bearing-value of brick varies with the texture of the material, its care in making and burning, and the skill with which it is erected into masonry when bonded with a suitable mortar. As shown by table, page 158, the safe bearing-value of brick masonry, in cement-mortar, is taken at from 8 to 10 tons per square foot, and experience has shown this to be a safe and conservative value. Numerous tests have been made upon piers erected under different conditions by the United States government and individuals, but it is doubtful whether such experiments are of much practical value.

While in no wise conclusive, the failure of a brick pier and the collapse and total destruction of a tower and tank designed by the author, gives an opportunity to present certain facts in that connection which may assist in throwing

some light upon the ultimate resistance of brick masonry under normal and actual conditions.

Below the ground-surface, with a bearing-soil of good, stiff clay, four piers of 6 ft. base and 2 ft. square tops, constructed of sound, hard-burned Georgia clay, laid in a mortar consisting of 1 part Belgian cement and 2 parts sharp road-sand, and into each of which two anchor-rods $1\frac{1}{4}$ ins. diameter with $12 \times \frac{3}{8}$ -in. boiler-plate washers had been inserted, had been constructed for the support of a 13-ft. diameter by 25-ft. high steel water-tank, supported by a four-column tower, 40 ft. in height. Upon the detail drawings a 24×24 -in. cap was shown, but owing to a misunderstanding as to who was to furnish this bearing-plate, the cap was not provided. A delay in securing the necessary anchor-rods from the manufacturer resulted in the purchase by the assistant engineer of a set of $1\frac{1}{4}$ -in., 5-ft. rods, supplied with the 12 ins. square boiler-plate washers. Later, when the original rods were received, accompanying them was a set of 12×18 -in. washers, which, through the carelessness and ignorance of the assistant engineer and the erecting foreman, were set on top of the foundations to serve as bearing-plates for the tower. The piers were completed exactly 45 days before the final test, at which time the tank was filled within 2 feet of its top, when the foundations gave way and the whole structure failed.

The weight of the material was 28,000 lbs., the weight of the water at $62\frac{1}{2}$ lbs. per cu. ft. was 192,000 lbs., the approximate weight of each pier was 9,000 lbs. At the time of the failure there was no wind blowing, so that the total weight applied as compression was 256,000 lbs., or 128.0 tons. With the 24×24 -in. cap specified, the bearing upon the masonry would have been 8 tons per square foot.

Under the conditions at the initial moment of failure, the entire weight of the tank and load, amounting to 110 tons,

was concentrated upon the 12 × 18-in. washer used as a cap, and this downward tendency was resisted by the holding-down power of three 12 × 12-in. washers in the three other piers, or a total of 648 square inches. Investigations made after the failure show that the excessive weight caused the column to puncture the pier through its entire length, coring out and completely crushing the brickwork contained between the two anchor-rods, representing an area of about 14 or 15 ins. square. Immediately below this core, the brick footings were intact, and a solid section 14 × 15 ins. was buried or driven into the bearing-soil of clay. The masonry around the column, which had penetrated into the solid masonry about 3½ feet, was not crushed, but was ruptured radially along the cement-mortar joints. Before the failure the piers were tested both with an engineer's and mason's spirit-level, and were checked as being truly horizontal and of the same height. The resistance offered by the subfoundation-soil to the penetration of the 14 × 15-in. section of footing course might be considered as amounting to 10 tons, and to that extent reducing the weight applied as downward pressure at the initial moment of rupture; under this supposition, the ultimate bearing of the masonry was 100 tons ÷ 4.5 = 22.2 tons. Although 45 days had elapsed since the completion of the piers, the cement-mortar in the centre of the pier had not fully hardened and was rather crumbly, although that exposed to the atmosphere nearer the surface was well set and very tenacious. After the failure the piers were torn away and new foundations, built upon the original dimensions, were substituted, and upon a 24 × 24-in. cast-iron cap the structure was built according to original design and has been perfectly stable during the past two years.

Concrete Foundations.—In general engineering work, concrete is a most useful material. It is formed of broken stone from $\frac{3}{4}$ in. to 2 ins. in longest diameter, of gravel, broken brick, shells, etc., the voids of the mass being filled with

cement-mortar of various proportions, depending upon the ratio of voids of the material. In practice, a good concrete can be made with one part of cement, two parts sand, and four parts broken material. In foundation-work, a good grade of Portland cement, sharp sand, and *clean* stone should be insisted upon. The volume of water used to incorporate the mass is the subject of never-ceasing discussion amongst the engineering fraternity, but in the author's practice a good concrete has been made by so dampening the mixture that after being deposited and rammed, a slight appearance of *water* upon the surface is all that is necessary. Concrete for small foundations is usually mixed by hand, upon a 12 × 12-ft. frame or light platform, the ingredients being placed conveniently. A proportion of sand, by measure, is first spread over the board into which is dumped the specified proportion of cement, and the two components thoroughly incorporated by the workmen with their shovels; spreading this mixture so that it shall be somewhat higher along the outer edges of the mixing-board, water is sprayed from a small hose upon the mass, which is quickly turned with shovels until every particle has been completely incorporated. Into this liquid paste the proper proportions of stone, after a drenching, are added, and quickly turned by the laborers until each particle of stone has been coated with the mortar. The concrete is then carefully deposited by the shovels of the workmen, in layers from 3 to 6 ins. thick, into the foundations. Such mixing and spreading by hand will cost approximately 60 cts. per cubic yard; the cost of the concrete will depend upon varying conditions, and will range from \$4.00 to \$6.00 per cubic yard in place.

Maximum Pressures.—The action of the wind upon the cylindrical surface of a tank and the application of that force as pressure upon the base has been previously explained. The normal pressure due to the load is the weight divided by

the area, and the maximum pressure to be transferred to the subfoundations will consist both of the normal and variable pressures. From the principles of resistance of materials, previously explained, the "live load" or variable pressure due to the wind can be found from the formula

$$\text{Wind pressure} = \frac{Ml}{2I};$$

and the maximum pressure will therefore be

$$\text{Max. pressure} \frac{W}{A} + \frac{Ml}{2I};$$

where M = moment of the wind;

l = the leverage at the base;

I = moment of inertia of the shape.

Where it becomes necessary to extend the base of a foundation in order not to overload the bearing soil, the foundations will extend in regular courses, and the safe projection of the successive courses will depend upon the pressure applied as force and the resisting quality of the material of which the courses are composed.

The theory of this action and resistance is given by Prof. Ira O. Baker, in "A Treatise of Masonry Construction," and is as follows:

"The area of the foundation having been determined and its centre having been located with reference to the axis of the load, the next step is to determine how much narrower each footing-course may be than the one next below it. The projecting part of the footing rests as a beam fixed at one end and uniformly loaded. The load is the pressure on the earth or on the course below. The set-off of such a course depends upon the amount of the pressure, the transverse strength of the material, and the thickness of the course.

“To deduce a formula for the relation between these quantities,

let P = the pressure in tons per square foot at the bottom of the footing-course under consideration;

R = the modulus of rupture of the material in pounds per square inch;

p = the greatest possible projection of the footing-course in inches;

t = the thickness of the footing-course in inches.

“The part of the footing-course that projects beyond the one above it is a cantilever beam uniformly loaded. From the principles of the resistance of materials we know that the upward pressure of the earth against the part that projects *multiplied by* one-half of the length of the projection is *equal to* the continued product of one-sixth of the modulus of rupture of the material, the breadth of the footing-course, and the square of the thickness. Expressing this relation in the above nomenclature and reducing, we get the formula

$$p = t\sqrt{\frac{R}{41.6P}}, \text{ or with sufficient accuracy, } p = \frac{1}{6}t\sqrt{\frac{R}{P}}."$$

This represents a theoretical maximum set-off for the masonry courses, but in practice, as has been explained, it is usual to reduce this theoretical maximum allowance by a suitable factor of safety, and, in this particular, a factor of safety of 5 to 10 is customary and considered a safe practice.

In addition to the forces acting upon the foundation-soil, the material of which the actual substructure will consist adds its weight to the other forces as pressure upon the sub-foundations, and therefore a general knowledge of the weight of different varieties of masonry is necessary. On the following page will be found a table giving the approximate weights of

the several building materials most generally used in stand-pipe foundation-work and compiled from various recognized authorities:

WEIGHT OF MASONRY IN TONS PER CUBIC YARD.

Weight of granite or limestone, dressed throughout (ashlar).	2.2 tons.
“ “ “ “ “ rough rubble.....	1.8 “
“ “ sandstone, ashlar.....	1.9 “
“ “ “ “ rubble.....	1.6 “
Brick masonry, medium work.....	1.6 “
Ordinary concrete.....	1.4 “

Designing Foundations, Including Anchorage and Capping.—To design a suitable foundation for a particular structure the normal weight must first be determined or assumed.

Considering a proper design for a stand-pipe 24 ft. dia. \times 120 ft. in height, and whose actual weight was considered as 80 tons, and whose dimensions would add 1696 tons as the weight of the water, or a total of 1776, and which weight should be first considered as acting over a base equal to the area of the structure, or 452.4 sq. ft., or with a unit-stress equal to $\frac{W}{A}$ or $\frac{1776}{452.4} = 3.9$ tons per sq. ft.

Neglecting for the moment the weight of the foundations, and which can only be obtained after a suitable design has been determined upon, to secure the maximum pressures per unit of bearing-surface, in addition to the normal weight divided by the area, there must be added the forces due to flexure or to the effect of the wind upon the cylindrical sides of the stand-pipe and as applied through its leverage to the base and over the area to be covered by the foundations.

Substituting the proper values in the formula $\frac{MI}{2I}$, or for a cylindrical figure 24 ft. dia. \times 120 ft. in height, and taking 30 lbs. per sq. ft. of diametral surface, as has been explained, as the action of the wind upon the sides of the cylinder, the force exerted by this variable quantity is

$$\frac{2592 \times 12}{32572} = .9 \text{ tons per sq. ft.,}$$

while

$$\frac{W}{A} = 3.9,$$

or a total of 4.8 tons per sq. ft. of bearing.

If, after suitable tests, the soil was considered capable of sustaining this load, the foundations could be carried vertically, and directly under the structure without any "spread," and in such a case only a sufficiency of masonry need be provided to secure a proper anchorage, and intended simply to resist the overturning moment, without increasing the bearing-area. In such a case, the stability of the structure having been determined by the principle of moments, as has been explained, and a sufficient number of rods provided to prevent the overturning of the structure, the holding-down power of these rods must be secured by designing for each rod a "washer" or bearing-surface, upon which a sufficient load could be imposed in the shape of masonry as to resist the effects of the horizontal action of the wind tending to overturn the structure at its toe.

Now this overturning moment has been found to be approximately 2592 ft.-tons, while the resisting moment, being 80 tons of material, multiplied by its leverage, 12 ft., is 960 ft.-tons, leaving an excess overturning moment of 1632 ft.-tons which must be resisted by designing some form of anchorage.

The load which the anchorage is required to resist is found by dividing the excess, 1632 ft.-tons, by the leverage of the anchorage, in this case say 12 ft.; hence the combined strength of the anchorage to prevent overturning is 136 tons, and the strength required of each rod is found by dividing this product by the number of rods.

Since the area of a circle represented by the base, 24 ft. diameter, is 452.4 sq. ft. for ordinary brick masonry whose weight is 1.6 tons per cubic yard, each vertical foot of foundation weighs 26.88 tons, therefore $\frac{1632}{26.88} = 6$ ft. as the height of the substructure.

As has been explained, the anchorage consists usually of iron or steel rods set in the masonry and bolted to some external shapes riveted to the superstructure. Such rods receive their holding-down or resisting stresses from flat washers supported by the bolt-head of the rod and acting against the masonry above, and must be designed of size and strength sufficient to prevent their being bent downward or broken off, and with a surface sufficiently broad to prevent the masonry from giving way, thereby permitting the washer and bolt to crush the masonry and pull through, and their bearing-area must therefore be such as to distribute the applied load over a sufficient portion of the masonry to prevent overloading and crushing.

If ten rods and washers were provided as anchorage and with a leverage of 12.5 ft., each rod would bear $\frac{1}{10}$ of the total applied stress, in this case $\frac{1}{10}$ of 1632, or 163.2 ft.-tons, and this divided by their leverage, 12.5 ft., each rod and washer must be designed to resist 13 tons pressure, or a total stress of 26,000 lbs.

Such washers are usually of cast iron with a unit maximum shear value of 20,000 lbs. per sq. in.

The safe bearing-value of masonry as taken from the table being approximately 10 tons per sq. ft. or 144 sq. in., for brick, the area of the washer to resist the applied stress would be $\frac{13 \times 144}{10}$, or 187.2 sq. in.; and if a circular washer were used, its diameter would be about 15 to 16 in. and the unit-stress 140 lbs. per sq. in. over the surface. The

transverse strength of such a plate or washer depends upon its thickness, and an exact formula is difficult to arrive at, but that used by Kidder is probably upon the safe side, and is as follows:

$$\text{Thickness of plate in inches} = \sqrt{\frac{W \times P^2}{1600}},$$

where W is the unit load per square inch—in the present case 140 lbs.; P , the projection of the edge of the plate beyond the rod, in this case say 6.5 in. Substituting these values in the formula, the thickness of the cast-iron plate or washer is a little less than 2 in. at its thickest part next the rod.

As a rule, the bearing-value of the soil will seldom be considered safe for a load as great as that considered above, and the bearing-value of the soil must be increased by spreading the foundations over a greater area.

In order to consider such a condition, assume that the bearing-value of the soil is not over 2 tons per sq. ft. of surface, and that the same conditions exist as were considered in the preceding example. Let the safe bearing 2 tons be represented by B , and $B = \frac{W}{A}$; then $A = \frac{W}{B}$. Let A be the total area and W the total load.

The total constant weight of the tank and water was found to be 1776 tons; the wind-pressure, approximately 1 ton per sq. ft., exerted over an area of 452 sq. ft., adds 452 tons; while the weight of the masonry was estimated at about 27 tons per vertical foot, and for 6 feet amounts to 162 tons, or a total, W , of 2390 tons. Substituting this value for W in the formula $A = \frac{W}{B}$, the required area of base is about 39 feet; but spreading the base increases the weight of the foundations, therefore some greater diameter must be selected

and determined by experiment. In order to allow for a marginal projection for the anchor-rods, the perimeter of the upper plane of a conic frustum, which is a suitable form for the foundation of a stand-pipe, might be that for a 27-foot-diameter circle, which would allow an annular space of 18 ins. around the 24-ft.-diameter tank. If such a conic section is considered in cross-section, the lower base projects beyond the upper with a length equal to half the difference on either side, and this projection, representing the spread of the masonry, is secured by offsets in the masonry courses, the number and height of such offsets determining the height of the figure or foundations.

As shown, the maximum theoretical projection may be determined from the formula $p = \frac{1}{8}t\sqrt{\frac{R}{P}}$; and if the masonry is in courses of brick whose thickness, t , is 2.5 in., with a modulus of rupture R , according to the table, of 800 lbs., and a pressure at the base, P , of 2 tons, substituting these values in the formula, the *maximum* theoretical offset is 8.3 in., to be reduced by the use of a suitable factor of safety.

The maximum *safe* projection of brick in single courses, as determined by practice and ordinance in many cities, is $\frac{1}{4}$ the length of a single brick, or a fraction over 2 ins., or a factor of safety, using the formula above, of 4, which, having been used in designing throughout, will be continued in foundation work where the masonry is an almost solid monolith.

For experiment, selecting a 44-ft.-diameter circle as the required base, the projection, being the difference between that and the 27-ft. diameter, or 17 ft., the projection on either side is 102 ins., and the projection allowed for each course being 2 ins., there are 51 projections, whose thickness being 2.5 inches, the height of the foundations is 10.6 feet. From these quantities the exact total weight can be determined, and is as follows:

Constant weight of tank and water.....	1776 tons
Wind-pressure exerted over foundation-base.....	517 "
Whight of masonry	<u>634 "</u>
Total applied weight and stress	2927 tons

Then if B , or allowable bearing-value, = W , total weight or 2927, $\div A$, total area or 1520, the actual bearing under the given conditions is 1.92 tons, or a bearing slightly less than the assumed safe bearing-value of the soil.

In designing the foundations for a tower and tank, the same formulæ and methods are employed. To determine the wind stress, however, the moment of inertia I is, of course, that of a rectangle or polygon, with sides bounding the figure formed by the base of the tower instead of that for a circle.

The supporting column of a tower must be provided with a footing or pedestal at its base. This should consist of a steel base plate, reinforced by angle connections and securely riveted to the tower post. Holes of proper area must be drilled for anchor rods.

The bearing-plate is subjected to direct shear from the total load concentrated and delivered by the metal of the column cross-section, and its unit stress should not be less than 10,000 pounds per square inch. In water-towers of small capacity the area of the bearing-plate may be made sufficient to safely distribute the load directly to the masonry, or a cast-iron cap may be provided, in either case, with area great enough to distribute the load upon the bearing surface so that it shall not exceed 100 pounds per square inch pressed.

Generally, however, it is considered more desirable and ornamental to surmount the piers with a capstone.

When this is specified the stone should be a monolith, sound and of close texture, preferably granite; its bearing surfaces at least should be "patent-hammer" dressed. An empirical rule for its dimensions is that its lowest bearing surface must

be such as to provide sufficient area to transmit the whole imposed load to the masonry without stress greater than 100 pounds per square inch, and its depth should not be less than $\frac{3}{8}$ times its length thus determined.

The bearing surfaces of all stones should be truly horizontal when set and the depth of each stone should exactly correspond.

Rod holes for anchorage must be carefully drilled from templates.

According to Baker, the crushing strength and weights of different stones are as follows.

	Max. Tons per Sq. Foot.	Wt. per C. F.
Granite.....	1510	178
Limestone.....	1440	174
Marble.....	1440	180
Sandstone.....	1080	175

In practice it is safe to assume the bearing value of single stones at from 15 to 30 tons, depending upon their characteristics.

The dimensions of the masonry pedestals must in each case be determined by the character of the bearing soil of the sub-foundations and the extent of the load to be applied; in other words, the base of the pedestal must be spread so as to provide a safe bearing and this spread will govern the height. Where the tower design fails to provide for ties connecting adjacent posts, the horizontal thrust of inclined posts must be resisted by the anchorage, and when thus resisted, the thrust produces an overturning moment in the pier which must be considered and provided for, usually by additional spread of the base, which produces a corresponding increased load and resistance.

CHAPTER XI.

PAINTING.

Discussion.—A lay-writer has clearly defined the science of engineering as “Common sense, directed by theory and practice, to works of construction,” and he might have added “whose comparative permanency was a prime consideration.”

This last, as a desideratum, it seems is frequently omitted by the engineer as well, and content with selecting materials and designing members, scant consideration is given to the necessity for effectually preserving the works of his creation when once they have been completed and tested.

Engineers' specifications for the protective coating for iron or steel too often exhibit a variability which permits almost anything in the nature of paint to be applied as a preservative, provided it is not too expensive, dries quickly, covers the ordinary stains, and for a time looks well.

A more satisfactory explanation is to attribute this neglect to a lack of knowledge rather than to a lack of interest, which is more to be condoned in view of the absolute diversity of opinion of those recognized as authorities as to what constitutes the best method of protecting metallic structures from corrosion and decay, and the further fact that possibly in the practice of the individual he has developed the anomalous idea that the cheapest paints have at times evinced, in actual use, superior qualities to scientifically correct and high-priced compounds.

A communication was received a short time since from a

well-known authority upon the manufacture and properties of structural steel in reply to a request for his opinion as to the best protective coating for steel, in which he says that he "knew no more about it than the average engineer. This is equivalent to saying that I know nothing, for there seems to be a radical difference of opinion on this question, and one engineer will claim that one kind of material is the very best thing that can possibly be used, and the next man will claim that it is the very worst. It reminds me of the investigation made by the *L. A. W. Bulletin* on the "Best Lubricant for a Bicycle." They published their conclusions, which ran about as follows:

1. Vaseline is the best lubricant.
2. Vaseline is no earthly good."

Considering the immense and increasing amounts of iron and steel used annually as structural materials for marine work, buildings, trusses, bridges and the like, and the limited and conflicting knowledge of the best methods of protection, it is surprising that accidents are not more frequent and serious, and that coroners' juries are not more often called upon to render similar verdicts to that given in investigating a celebrated bridge-failure and accident, where the jury found that "All went in, none came out, and there is nothing to sit on."

Iron-rust.—Although the best methods of preventing corrosion may be involved in uncertainty and dispute, the cause of the destruction of ferric members seems to be fairly well established and it is a generally accepted scientific theory that, primarily, rust or metallic corrosion is the effect of a chemical combination of carbonic acid gas, oxygen, and water with metallic iron, producing ferric oxide or iron-rust which, once affected, continues with great rapidity through both chemical and galvanic action.

It has been shown by frequent experiment that carbonic acid gas and oxygen, together or separately, will not pro-

duce the phenomenon of rusting until water is added to complete the compound. Fresh water alone, when free from acids or organic impurities, has been found to have but little effect upon submerged plates of bright iron or steel, but where the plate is entirely or intermittently immersed in salt water, the salt water, taking the iron oxides into solution, removes the oxides and exposes fresh metallic surfaces to attack, also setting up a voltaic action upon ferric bodies.

Structural work is generally exposed only to atmospheric action, the atmosphere being sometimes charged with salt-sea vapors, and always with some moisture, in addition to the three universal components—nitrogen, oxygen, and carbonic acid gas—in the presence of which the destruction of ferric members is sure; the intensity and extent of this action being directly dependent upon the quantities of each element entering into the chemical action.

Chemical and Galvanic Action.—The chemical reaction in such cases is the setting free of the hydrogen of the water, its oxygen, uniting with the carbonic acid and metal, forming ferrous carbonate, which again combining with the oxygen of the water or atmosphere, is decomposed into ferric oxide and carbonic acid gas, the latter passing off, leaving the sesqui-oxide of iron to absorb and condense water, becoming the hydrated sesqui-oxide of iron whose symbol is $2(Fe^3 O^3)_3H_2O$, ordinarily known as iron-rust.

It is a familiar fact that bright iron or steel may, under favorable conditions, be kept unprotected free from rust for a considerable time, but that when once the process of rusting commences, the rust specs, as centres of corrosion, rapidly spread until the entire metallic surface becomes covered with a sheet of rust. The chemical explanation of this progressive action when rusting has once commenced is, that during the decomposition by-oxidation of the ferrous carbonate to ferric hydrate, the entire amount of carbonic acid is not given off,

and acts upon the new surfaces of the metallic iron, and owing to the porous and hygroscopic character of the rust crust, only small quantities of oxygen and moisture are necessary to indefinitely continue the process, the hydrated oxide giving no protection to the underlying metal. The capacity of rust for absorbing and condensing moisture and oxygen is enormous, and it has been proved that iron-rust will absorb as much as 27 gallons of oxygen-gas in making one pound of rust.

It seems beside the strictly chemical action, there is a galvanic effect which augments the work of corrosion and destruction when once begun; for it has been shown that the oxides of any metal are electro-negative to the metal itself, and that in ferric oxide a voltaic action is set up in its fibres and surfaces in contact by thermo-electric currents due to changes of temperature of the body; further, that the contact of such products as iron and steel is sufficient to set up such action, the result being a pitting and corrosion of the material, now technically known as electrolysis; and it has been asserted that the difference in the molecular arrangement of the *same* materials—due either to manufacturing methods which result in lack of homogeneity, or from the unequal application of force as stress that changes the arrangement of the fibres—is sufficient to produce voltaic destructive action.

Mill-scale.—In rolling iron or steel, the scale sometimes left upon the surface of the metal, and known as “mill-scale,” has been analyzed as sesqui-oxide of iron, Fe^2O^3 , the same chemical composition as ordinary iron-rust, and it seems further to possess to the same marked degree the capacity for absorption and condensing moisture and oxygen, producing corrosion and decay, and setting up galvanic action, the effect appearing in rust-cones pitting and eating the metal.

It is asserted that where mill-scale is left upon plates of

steel its effect upon the neighboring bared metal is as strong and continuous as copper would be in its galvanic action.

Overwhelming testimony and positive evidence have proven the following facts:

1st. That rust and mill-scale exert a most destructive action upon iron and steel.

2d. That where moisture and carbonic acid gas accumulate in considerable quantities, the rapid destruction of ferric bodies follows.

3d. That rusting, once started, progresses rapidly even under what seems a perfect protective covering.

4th. That if a covering can be found which will prevent the penetration of moisture, the perfect protection of the metal is assured so long as the covering remains intact.

In 1882 exhaustive experiments were conducted by authority of the British Admiralty, resulting in the following conclusions:

(1) That no pitting occurred in mild steel when freed from mill-scale; (2) that the loss of weight from corrosion of clean mild steel and clean iron did not differ greatly; and (3) that the action of mill-scale is considerable and continuous, and equal to a similar quantity of copper in its corrosive action due to galvanism.

In long tunnels in which accumulations of carbonic acid gas and moisture are found, and as exemplified by the Arlberg, St. Gothard and Musconetong tunnels, the life of iron or steel work is very brief, and a renewal every few years has been a necessity; in the last of these, it is reported that the 76-lb. steel rail was removed after five years' service and was found to have lost more weight by corrosion than by use.

The continuous action of rust is clearly shown by a report to the French Naval Office as to the effect of rust upon several torpedo-boats which had never been put into commission, but were laid up under cover and painted at intervals. An inspec-

tion showed that the plates under the paint were so corroded that the blow of a testing-hammer was sufficient to puncture them, and that large areas under the paint-film were so affected. This same effect of the continuous action of rust has been observed in the repair of numerous bridges and other structures, when the metal was found entirely destroyed under the paint-coating. A large truss-roof that was kept constantly painted having failed, it was found that the metal was simply rotten with rust under the paint, while no appearance of the instability of the structure from this cause was apparent to the eye. The same result is recorded by builders in the case of floor-beams which were practically eaten away below the paint-surface.

A recent investigation by Mr. D. H. Maury, of the electrolytic injury to the metal of the Peoria, Ill., stand-pipe is of great interest, and is given as follows:

“On March 30, 1894, the water company's steel stand-pipe on the West Bluff burst, killing one person and injuring 15 others, one of whom died later from his injuries. Upon examining the wreck of the stand-pipe, the writer at once noticed a peculiar pitting of the inside of the vertical sheets, and the appearance of these pits was so different from that caused by any ordinary oxidation that he was soon almost positive that they were due to electrolytic action. A similar stand-pipe on the East Bluff was drained, and was found to be similarly pitted. The whole inner surface of the vertical shell appeared to be thickly covered with blisters, resembling in outward appearance the tubercles sometimes found inside of old cast-iron mains.

“This blistered covering, which was almost as thin as paper, was composed entirely of oxide of iron, and on brushing it away with the finger-tips, the black paint with which the stand-pipe had been originally coated would be found beneath it.

“The black paint was oftentimes almost unbroken, or at least, very slightly cracked. When the paint was brushed off, the pit would be disclosed, considerably smaller in area than the surface covered by the blister. The surface of the metal in the pit was perfectly bright and clean, and its fibre was clearly discernible.

“Many of these pits were more than $\frac{1}{8}$ in. in depth. They were slightly more numerous in the West Bluff stand-pipe, and were in both generally larger and deeper on the lower courses of the vertical shell. . . . The East Bluff stand-pipe was distant about 60 ft. from the street-railway line on Bourland Street. The West Bluff stand-pipe was about 700 ft. distant from the railway line on Knoxville Avenue. Both stand-pipes were more than a mile from the power-station, and were negative to the rails. The electrical examination relative to the stand-pipes was conducted mainly at the East Bluff stand-pipe, which was still in service. A flow of a part of the current from the railway line was clearly traced through the earth to the anchor-bolts which held the stand-pipe to its foundations, up these bolts and into the steel of the shell, and through the shell and from its inner surface to the projecting section of the 16-in. flanged cast-iron pipe which served as both inlet and outlet, and which connected the stand-pipe to the water-mains. The current was then traced along this pipe and along the mains to the power-station. The deflection of the volt-meter needle was clearly traced to the railway current, being especially influenced by the one or two cars on the line beyond the stand-pipe on Knoxville Avenue, and when the cars stopped running at night, the movement of the needle ceased. Where the current left the inner surface of the shell to pass through the water of the inlet-pipe it made the pits already described. These stand-pipes and the inlet-pipes were negative to the rails, and are striking examples of electrolytic pitting under such conditions.”

From the history of the Peoria stand-pipe, it having been noted that the specifications called both for iron and steel as structural materials and desiring to ascertain whether galvanic or battery action might not have been the result of the iron and steel in contact in the presence of moisture, the author wrote Mr. Maury, receiving a reply in which he stated that he did not think anything but steel plate had been used in the construction of the stand-pipe, except the rivets, and possibly the ladder and some connections; that careful investigations looking for battery action were made, but this action had not been substantiated.

Cleaning the Metal.—It having been shown and demonstrated that it is of prime necessity to prevent the commencement of the rusting process in its incipiency, and that the first consideration is to provide for the thorough cleaning of the metal before an attempt is made to give it a protective covering, it is in order to discuss the methods employed for this process of cleaning or preparation for painting.

For this purpose there are three processes in vogue and in general use. One is by "pickling"; another by the use of the sand-blast, and a third and more general method is by scraping and cleaning with wire brushes.

The pickling process consists in the submersion of the plate or shape in a bath of hydrochloric or sulphuric acid for a period of one-half to twenty-four hours, and afterwards neutralizing the acid by the use of lime, the lime then being cleaned off. The proportions of acid to water range from 10 to 19 parts of water to 1 of acid, the latter being the formula adopted by the British Admiralty. Such a method of cleaning plates, while reasonably economical and convenient, and fully effective when carefully performed, is open to the objection that any carelessness upon the part of the workmen is sure to produce results which are worse than the proposed cure. The second method of cleaning metallic surfaces is a mechani-

cal one, sharp-grained sand being employed under about 15 pounds compressed-air pressure at the nozzle, to cut away the rust and mill-scale, by being directed to the desired point from the end of a rubber tube or hose. While a certain method of cleaning when intelligent care is exercised, and the penalty for negligence not being so severe as where acid is used, the objection recorded to the use of sand is that a special building must be provided, from the fact that, unless the sand is confined, it is likely to prove damaging to machinery and become generally a nuisance.

The last and most popular method of cleaning plates and shapes is by the use of scrapers and brushes, either by hand or mechanically, electric revolving brushes being considerably used of late. The loosened material is wiped away with oiled waste or rags. Nearly all of the larger bridge-works clean their shapes in this way. The objection to this is that although the surfaces may seem bright and free from rust and scale, under a glass it will be seen that only the microscopic metallic points have been burnished, the depressions showing minute rust-specks which have not been touched by the scraper or brush, and may therefore become points or foci for corrosion. For these reasons, it would seem that specifications for the cleaning of metals should be drawn to include the use of the sand-blast, the cost of which is about the cost of a coat of good paint, and is said to be about \$1.50 per ton of metal, exclusive of handling. During its evolution, the time at which the metallic member should be cleaned and primed is of great importance. In an investigation of this question, a testing-bureau, having a wide experience and facilities for observation, writes as follows: "In rolling a plate, a slab is drawn from the heating-furnace or soaking-pit, and it passes through the rolls. As it is being reduced, salt is thrown upon the slab; it causes a loud explosion, and loosens the scale formed and a steam-jet is turned on the slab, which blows

this scale off, so the finished plate comes with no scale upon it to the cooling-beds. In the rolling of angles and similar shapes it is not possible to do this. Therefore, there is more scale upon the angles than on plates. After rolling, shapes are as a rule stacked immediately upon loading-beds preparatory to shipment, it being against the mill's policy to hold material any longer than it is necessary to get cars and to load. Shapes after they come from the strengthening-press, which is directly after cooling, are not under cover. In case of plates, the conditions are different. After the plates are rolled they have to be laid off and sheared to size, and then stacked up awaiting shipment. In the majority of cases this is always under cover. Open cars are nearly always used in shipping steel, on account of the convenience in loading from cranes and also on account of the variation in lengths." The above explains the processes and evolution at the mills, and in order to arrive at the condition at which the material reaches the shops, inquiry was made of a large boiler and metal-working establishment, located from 600 to 700 miles from the point of metal-supply. They write: "We find very little rust, mill-scale, or grease on any of the sheets coming from the mills; though we must confess we find much more now than we used to heretofore. . . . There is a big difference in the steel plate from the different mills; there is a gloss or finish upon some, while from another mill they appear red, as though they were rusted. Now any of these plates will stand the weather without being injured or rusted, especially the ones best finished, and it is not necessary, in our opinion, to paint or oil the plates at the mill. The effect of rolling plates after they were painted would be to scale off much of the paint." From such testimony it appears that, under ordinary circumstances, it is not necessary to protect plates at the mill by painting or priming, and that at the shop the mechanical work of rolling to radius, as for boiler and stand-pipe plate,

and the punching and handling of untreated plates and shapes, as well possibly as the jar of railway transportation, and the several handlings, loosen more mill-scale than enough to compensate for any rusting in transit, and that therefore the proper time to clean and prime is at the shop, after the mechanical work has been completed, and immediately before shipment to the point of erection, any grease which may result from the machining being also subject to removal at the same time. The facilities for cleaning and painting being usually superior at the shop to those likely to obtain at the point of erection, is another consideration in favor of shop-cleaning and priming. Structural metal, when carefully cleaned of all rust, mill-scale, grease, and dirt, should be immediately protected by some covering as nearly impervious to moisture as possible in order to prevent further corrosion from chemical and galvanic action.

Zinc Coating.—It has been found that the application of molten zinc, called "spelter," as a bath, forms a coating which is electrically positive to iron or steel, and which in the presence of galvanic action results in the corrosion of the zinc and the protection of the ferric body. Such a coating is very effective, but with the larger plates, where the dipping is done by hand, the process is very expensive, $\frac{3}{8}$ in. plate being the thickest material so far galvanized for practical purposes, the cost being from \$14.00 to \$16.00 per ton. Besides the expense, unfortunately the process reduces the strength of plates and shapes to an extent that galvanized metal is generally considered as being "rotten" and unfit for use where certain and considerable strength is required.

Again, it has been asserted that water in galvanized receptacles or reservoirs becomes unfit for use, which, if true, would debar this method of protection either for the towers and members where strength was required, or for the tank, where the storage of water was the purpose of the structure.

A small municipal water-supply plant in use in California has two small galvanized tanks in service, which seem to have given satisfaction.

“Oxidized Plates.”—Another method of treating steel or iron plate for protection against corrosion, popularly called “oxidizing,” has been accomplished in several ways with satisfactory results, the effect being produced by heating the metal, and afterwards subjecting it in a furnace to the action of mingled steam and carbonic acid gas, resulting in the production upon the metallic surface of a coating of the black oxide of iron, $\text{Fe}_2\text{O}_3\text{FeO}$.

It is claimed that the same result has been obtained by coating the metal with a mixture of red oxide of iron, containing an almost equal amount of silica and in a solvent of resin-oil, and afterwards heating the metal to a bright red. It is also claimed that the metal, heated to about 300 degrees Fahr., and immersed in an asphaltum mixture of the same temperature, will produce the same black oxide coating, but in this case it would seem that the plate must first have commenced to rust naturally, to produce the change from red to black oxide. In some of these processes, the change in the strength of the material is not more than that which would be produced by annealing, but in the first of these methods it is certain that the iron or steel is permanently expanded, which would be a certain advantage. The protective power of the black oxide film or coating is shown from the record of an iron column, said to have been erected at Delhi, India, about 900 B.C., and which is 60 ft. in height and weighs about 17 tons. After the lapse of ages, the surface is free from rust and otherwise unaffected by weathering.

Japanned Plates.—A permanent, hard and enamel-like coating, capable of successfully resisting the effects of corrosion, is known as “japan,” and is produced by treating the article to be protected to a composition consisting of asphalt

and linseed-oil, as a base, with copal resin, thinned with turpentine, subjected afterwards to a slow heat in an oven or furnace, a process of baking. Trays, ornaments, door-locks and knobs, and small articles have been successfully treated to this process, and of late, experiments upon a larger scale have been made.

Practical Considerations.—While the adoption of such processes is known to afford more effective preventatives to metallic corrosion than any other method of covering so far developed, the effect upon the metal itself, the cost and inconvenience of operation, and the necessity of especial appliances would seem to debar such means from practical and general use for the protection of structural material, frequently in heavy masses; depending for its usefulness upon its certain and known strength, and whose manufacture, commencing at the mill, continuing at the shop, and possibly proceeding at remote points of erection, seems to permit the employment of no means which is not simple, convenient, speedy, and economical, which conditions are more nearly fulfilled by the protection afforded metals through paint-films, and it would therefore appear that, comparatively, they are the best protective coverings for iron or steel. As such agent, the records of the past leave much to be desired, and it should therefore be the serious effort of all engineers or other scientists, both chemists and physicists, to continue in an effort to develop this protective agency to the highest attainable degree.

Paint-films.—Paint is used for purposes of ornamentation as well as for protection, but only in the last of these functions will it be considered here, where the practical, rather than the æsthetic, is the prime consideration.

Paint is a film of one or more coats or thicknesses, which may be applied or spread with a brush over any surface, and

primarily consists of a liquid as the vehicle or medium, with which a base, or pigment, is in combination or solution.

A perfect paint should be tenacious; non-corrosive; elastic; impervious; of easy application; of reasonable covering and drying qualities, and of comparative economy.

The usual causes of the destruction of the paint-films when applied to such structures as metallic iron or steel tanks are expansion and contraction of the metal; sand or other sharp particles; or rain and sleet, contained in gusts of wind impinging upon the paint-film; the chemical and galvanic effect of light and heat, in the presence of moisture and gases, and acting upon the paint-substances; the lack of adhesion of the film to the metal, usually caused by the presence of moisture upon the metallic surface previous to the application of the film, resulting in "peeling," and finally the destructive action of the water enclosed in the tank upon the oil, causing swelling, shrivelling, disintegration, and a slumping away of the film.

Linseed-oil.—However much individuals may disagree as to the character of the pigment, linseed-oil as a medium or liquid vehicle, which has been used since the remote ages, continues the standard of efficiency.

Linseed-oil is a product obtained from grinding flaxseed to a coarse meal, which is heated and sacked, and being placed under powerful presses, the oil is extracted in a crude shape, and is refined by sedimentation and filtration extending over a period of from one to three months, becoming "raw" and "commercially pure" linseed-oil, costing from 55 cents to 75 cents per gallon.

"Boiled" linseed-oil costs a little more, and is produced by heating raw oil to 400 or 500 degrees F., at which temperature the vegetable matter of the oil is attacked, at which stage from 1 to 3% of either litharge or the red oxide of lead, sometimes with a small quantity of the oxide of manganese, is

added. Raw oil requires from five to six days in drying, while the boiled oil dries in about one-fifth the time.

No other known oil has the power for absorbing oxygen that is possessed by linseed-oil, but in the process it has been shown by Muelder that the oil gives off carbonic acid, acetic and formic acid, and possibly water-vapors, the slow escape of which probably accounts for the well-known porosity of the dried film, and on account of which the film has remarkable absorbent capacity, acting like a sponge in the presence of moisture, which Dr. Dudley considers the primary cause of the decomposition of the material, although not satisfied that the water itself is the cause of the decay.

Like other vegetable fixed oils, linseed-oil contains glycerine and liquid acid fats. According to many authorities, these fats in the presence of oxides, especially lead, produce salts by the combination of the acid fats with the lead of the oxide; saponify, resulting in metallic soaps. Amongst others, Prof. J. Spennrath combats this theory with many valid arguments, amongst which he asserts that "if we should treat any soap with diluted acid, which is capable of dissolving the metallic oxide contained therein, it is decomposed, and the fatty acid separated. The latter then swims in the liquid. A dried oil-paint can never be dissolved by diluted acid in this way." Again, "a weak alkalized liquid, for instance, a one per cent. soda solution, dissolves after a prolonged application any dried-up oil-paint coating. We then obtain the coloring matter what was used in an unchanged condition. A real soap cannot be decomposed by a soda solution."

Prof. Spennrath admits, however, that the rapid effects of oxidation produce more or less effect upon any oxidizable pigment, and several other recognized authorities assume, in the case of at least one such pigment—the red oxide of lead—that a chemical combination is produced, analogous to sapon-

ification, but with also a cement-like action, the substance "setting" into a compact mass during a short space of time.

Linseed-oil, then, alone or in combination with some inert pigment or substance, absorbs oxygen rapidly and in considerable quantities, wherever found, at the same time throwing off volatile gases, becoming porous and absorptive as it hardens into a tenacious, elastic vegetable gum; while in solution or combination with active mineral oxidizable compounds, a radical change takes place, the resulting substance being analogous to a metallic salt or soap, but evincing cement-like properties.

Pigments.—Of the *elementary* substances as a base of paint mixtures, it is generally conceded that Carbon C, as lampblack (or graphite), or the hydrocarbon asphaltum has given the best results for a metallic protective covering, while in the opinion of many the metallic oxides as red oxide of iron, (Fe_2O_3) and the red oxide of lead (Pb_2O_4) give equal or better results. These substances have been used singly, in combination with each other, or mixed with some of the "inert" pigments, such as silica, kaolin, talc, whiting, gypsum, etc. Comparisons, endeavoring to show why certain of the many pigments should *not* be used, have been so often made by eminent scientists that it will be the attempt of the author to give some reasons for the faith that is in him as to why certain of these bases *should* be used upon metallic structures, such as stand-pipes, not affected by heat or by sulphurous gases.

Before the American Society of Mechanical Engineers, June, 1895, Mr. M. P. Wood, a member of the society, read a paper entitled "Rustless Coatings for Iron and Steel," which is remarkably clear and interesting, and from which is quoted the following:

— "Red Oxide of Lead, Pb_2O_4 (Minium).—This oxide is found native in various parts of the world, mixed with other

ores of lead, and probably resulting from their oxidation. In some localities it accompanies cerusite or white-lead ore.

“When prepared for analysis, or when the commercial article is freed from the protoxide by digestion with a solution of acetate of lead, it contains 90.63% of lead and 9.37% of oxygen, numbers agreeing exactly with the formula Pb_3O_4 .

“It may be regarded either as a compound of the protoxide and peroxide of lead $PbO.PbO_2$, or perhaps of the protoxide and sesquioxide, $PbO.Pb_2O_3$, analogous to the magnetic oxide of iron. Its specific gravity ranges from 8.6 to 8.94.

“The commercial red oxide of lead is formed when the protoxide is kept at a low red heat for a considerable time in contact with air; also, after the previous formation of hydrated protoxide and basic carbonate of lead, when lead shavings are strewn upon the water, the vessel being loosely covered and set aside for some months, the formation of red lead taking place upon the surfaces of the lead exposed to the air. . . . Commercial red lead contains all of the foreign metallic oxides—such as the oxides of silver, copper, and iron—with which the *massicot* or *litharge* used in preparing it is contaminated. It is also adulterated with red oxides of iron, boles, or brick-dust; these substances remain undissolved when the red lead is digested in warm dilute nitric acid; boiling hydrochloric acid extracts the sesquioxide of iron from the residue. . . . The use of red lead as a pigment is possibly of earlier origin than any of the oxides of iron, ochres, and other substances, natural or artificial, of which we have any record, unless it be asphaltum or lampblack. The many miscellaneous pigments which have come forward, been tried, and found wanting in some one or other of the qualities which constitute a good paint are almost numberless. There is no other color-pigment whose use as a protective covering to wood, brick, stone, or metal has been so uniformly satisfactory and successful as red lead, and any failure to fulfil its mission

can be traced directly to some agency foreign to the lead itself, used either in its preparation or in the methods of its application."

A paper read by Prof. A. H. Sabin, before the Boston Society of Civil Engineers, November, 1899, says of the red oxide of lead: "There yet remains to be described one other important pigment, red lead. This is entitled to a place in a class by itself, because it is intermediate between the paints, which it resembles in being used mixed with oil, and the cements, which it resembles in its process of solidification. It is, in fact, a powerful basic substance, and combines chemically with the oil, forming an insoluble, hard, tenacious mass, in which the uncombined particles of the excess of red oxide are imprisoned. This is what constitutes the protective film when a red-lead paint is dry."

By some authorities it is claimed that in the chemical combination the glycerine, as well as the acid fats, is changed by the lead oxide, volatilization of the glycerine being prevented, but in oxidizing through the process common to all linseed-oils, the mass is rendered insoluble, elastic, and adhesive; but it seems very probable that the glycerine, not being a stable product, soluble in water and volatilized by heat, acts as described by Muelder, the film being rendered more or less porous by the escape of the gases.

Litharge mixed with commercial glycerine to a pasty mass takes a most hard and tenacious "set" when exposed to the action of the atmosphere for twenty to thirty minutes.

It is stated by Wood that, during the process of setting, red lead and oil will oxidize the surface of clean iron or steel, forming the black oxide of iron which is non-corrosive. It is also believed to be a fact that where moisture exists upon the metallic surface, the oil and lead rapidly absorbs this in the chemical change requiring oxygen wherever found.

These estimable qualities, however, are offset to a certain

extent by the well-established facts that, on account of its specific gravity being far in excess of that of the oil, when mixed and spread upon perpendicular surfaces, the paint "runs" or "sags," the pigment separating from the oil, the coat producing a streaked appearance and not affording an even covering, and it would therefore seem that its use should be confined to metallic plates and shapes before assembling and where the coating can be applied while the member is horizontal or nearly so.

Again, owing to the rapidity of oxidation, the red lead and oil sets so quickly that it is of difficult application, but this objection can be partly overcome by an addition of a carbon-pigment, such as lampblack, which is an impalpable powder, practically indestructible, in a measure elastic, with the power of repelling moisture, and itself one of the best-known preservatives of metals, but comparatively useless when applied alone, from a fault in an *opposite* direction; that is, it takes *too long* to dry.

In conjunction, these two pigments modify the opposite objectionable properties of each, while the fine carbon-powder assists in filling any voids in the mass, due to imperfect combination.

In the manufacture of such paint it is a prime necessity that, to produce satisfactory results, each ingredient should be chemically pure, and the degree of purity will determine the relative efficiency. Suitable proportions have been found in 20 pounds of red lead, 1 pound of carbon as lampblack to 5 or 6 pounds of raw linseed-oil. The bulk will be about 1 gallon, with a covering capacity of about 50 square yards of surface for the first coat, the film being approximately .002 of an inch in thickness. The cost will be about \$1.50, and the amount paid for labor in spreading will run about 5 cents per square yard where the services of an experienced painter are employed.

While the preponderance of evidence is in favor of the use of red lead in oil for protective coatings for iron and steel, numerous failures are recorded, but as a comparison of evidence might be continued *ad infinitum*, such a task will not be attempted here, further than to mention the results of a series of tests, extending over two years, and made by Prof. Sabin upon steel plates coated with a wide variety of paint covering, the samples being afterwards immersed continuously and subject for two years to the action of both salt and fresh waters. Prof. Sabin's conclusions, represented in a paper read before the Engineers' Club of Philadelphia, May, 1900, were that "the character of the pigment in a majority of cases made very little difference: that oil-paints did not withstand the action of the water as well as varnish-paints," but that "red lead stood better than any of the oil-paints. There is no question about it. It did not stand as well as many varnish paints. It did not stand as well as some varnishes without any pigment in them."

Structures are not as a rule subject to such action of the water as took place in Prof. Sabin's experiments, and while these were very carefully made and recorded, certain results where metal plates were submerged would not necessarily have a distinct bearing where a structure is subject only to atmospheric influence; but in view of the fact that such structures as tanks, intermittently or continuously filled with water, are the prime subject of consideration here, his experiments are of considerable value.

Asphaltic Varnish.—Varnish differs from paint only in the base—the medium, linseed-oil, remaining the same. In varnish, the pigment gives place to various resins, dissolved in the spirits of turpentine, a volatile oil. These resins are of vegetable origin, and are classed as "recent resins," the resinous gum of a recent period, and "fossil resins," the volatilized gums of trees long buried in the earth. Varnish resins are

largely found in Africa, South America, New Zealand, and the East Indies. The general process of varnish manufacture is the heating, in a suitable receptacle, of the resins to from 600 to 800 degrees F., at which point the resins melt, being decomposed by the heat.

At this point, hot linseed-oil is added, and the contents stirred until fully combined; after cooling, the mixture is dissolved or diluted with spirits of turpentine, to permit the proper flow of the varnish under the brush. The greater amount of oil used, the greater the elasticity, tenacity, and toughness, and the less brittleness, which are desirable qualities where the varnish coat is subject to mechanical injury. In addition to the vegetable resins, a "mineral resin," as it has been called, or asphaltum, is often used. Its oil, by dry distillation, is of a yellow color, and said to resemble closely the oil of amber. Used in considerable quantities in the manufacture of varnish, it exhibits remarkable non-drying qualities, but its compensating advantages are its cheapness, elasticity, tenacity, durability, and insolubility.

Prof. Sabin gives the following why varnish is better than oil: "The reason why varnish is better than oil is that it is more durable, smoother, and more brilliant, and because the resin dissolving in the oil makes it harder; it makes a film that is harder, and still retains a high degree of elasticity—not so much elasticity, perhaps, as the original alone, but a very high degree of elasticity; and it is very much more impervious to moisture than oil."

From a paper read June, 1895, by Prof. A. H. Sabin, before the American Society of Civil Engineers, the following is quoted:

"It has long been known to varnish-makers that the fossil resins known as copals, such as the New Zealand kauri, when added to asphalt-varnishes, improve their durability. This is probably partly owing to the fact that such compounds are

of greater density, as the resin dissolved in the oil and asphalt tends to make a more compact substance, and partly because it increases its electric insulating power, also in considerable measure because such a resin is very indifferent to the action of sulphur-gases. For all these reasons it seems to the writer that the maximum of durability is only to be reached by a compound of hard asphaltum, copal-gum, and linseed-oil, thinned, if necessary, with pure turpentine. It is of the highest importance that the oil employed should be so refined as to have its non-drying constituents removed, so as to avoid as much as possible the use of dryers. This is of more importance than in a pigment and oil-paint, because the most obvious thing about asphalt is mentioned in the observations of M. Riffault, made some thirty or forty years ago, that 'asphalt destroys the drying quality of oil.'

This is due to the fact that, being a viscous substance, it closes the pores of the oil and thus obstructs the entrance of air and moisture, which is also the cause of the great durability of such compounds.

Not only is it necessary to have the most suitable materials in such proportions as experience has shown to be best, but the ingredients should be compounded in the most approved manner.

Long experience has shown that there are certain temperature-curves to be followed in combining certain materials, differing for different compounds, a departure from which injures the durability of the resultant compound. The upper parts of the curves approach dangerously near to the decomposing point of the oil, and it has been found that a suitably refined pure oil has that point more than 100 deg. F. higher than common oil; it is on this account, also, important to use the highest skill in the manufacture. The choice of ingredients is of less importance than their proper proportion, and this again is of no more value than the use of the best process

of combination. Against the use of varnishes upon metallic surfaces, it has long been pointed out that, on account of the volatile properties of the medium, either turpentine or benzine, its rapid evaporation causes a fall of temperature, causing a deposition of moisture upon the surface, which acts deleteriously upon the resin or gum of the varnish, while preventing the proper adhesion of the film to the metal, and possibly causing the commencement of the corrosive action of moisture upon the metallic surface.

The cost of a well-prepared asphaltic varnish, of pure materials, will be about \$1.50 per gallon, which will cover about 40 sq. yds. of surface, one coat.

Application.—It is generally conceded that two coats of good paint will last at least three times as long as one coat, and that the first, or priming coat, is of especial importance.

In the prize essay of Prof. Spennrath, Director of the Technical School at Aix-la-Chapelle, upon "Protective Coverings for Iron," his conclusions are that: "It is therefore advisable, in putting on iron coatings, to prime with a paint as heavy as possible and have the upper coat rich in oil." The specific gravity of red lead being shown to be about 9.0, it is the heaviest known pigment in use in the preparation of paints.

In a number of exhaustive tests, Prof. Spennrath distinctly traces the bad experiences with red-lead coatings to the action of heat, under which conditions the metal expands, the paint-skin remaining hard and brittle, a severe stretching takes place, cracks and rents develop in the paint-coating, and as a consequence rust appears. Where the atmosphere contains hydric sulphide, the red lead is changed to the sulphide of lead, according to Prof. Spennrath, to which he attributes the sole specific weakness of red lead as a pigment.

To sum up, in favor of the use of red lead and oil is its well-known high specific gravity and its peculiar chemical

property of combination, resulting in the production of a coating or film of a particularly tenacious, hard, and insoluble character, when not subject to great heat or sulphurous gases, which is seldom to be considered in connection with such structures as towers and tanks. The red-lead paint, however, lacks elasticity, resulting in the formation of air-cracks, and its porosity from the escape of volatile gases during the process of hardening seems to be well established. Moreover, its high specific gravity has the disadvantage of causing the pigment to "sag" or run away from the oil when being applied, resulting in streaking or imperfect and uneven covering, while its quick-setting qualities render this paint unsatisfactory and difficult to handle. This last tendency may be in part or entirely removed by the addition to the mixture of carbon, usually in the form of lampblack, which further aids, as has been shown, in diminishing the porosity offered as an objection to the use of lead and oil, while if the paint is used, as before erection, upon materials and surfaces which may be placed horizontally or nearly so, the pigment has little or no opportunity to settle out of the oil or "sag."

For all the reasons submitted, it would appear that as a priming coat, or first coat, red lead, lampblack, and linseed-oil, when applied upon iron or steel surfaces of structural material before erection, affords the best known protection to metallic corrosion; it is also a well-established fact that red lead, usually as a red-lead paste, is used in water and steam-pipe fitting to produce a close and perfect joint, and that when applied upon the laps of steel plate intended to be used in water-tank construction, the same tendency toward producing a water-tight joint is observed, and the use of this material for such purposes minimizes the most objectionable practice of making it necessary to resort to a natural or rust-joint to secure the necessary degree of tightness between the metal plates.

It also seems equally sure that suitable finishing coats should be provided and applied over the priming coat, and that this last film should be of small specific gravity, elastic, impervious to moisture, hard, and tenacious; it should be indifferent to sulphurous gases and electrically insulating, all of which properties seem to be fulfilled to a greater degree by an asphaltic varnish than any known varnish or paint composition. On account of its ease of application and quick-drying powers, it is particularly suitable for application upon structures being erected in the open air and exposed to the weather, while the characteristic of a volatile composition to produce a deposition of moisture is of no consequence when that moisture is not formed upon the metal itself, but upon a cement-like coating, which, besides, has a power for decomposing moisture by the absorption of its oxygen.

Either paint or varnish coats should, when possible, be put on under the most favorable atmospheric conditions, the best season being during the autumn, when the temperature is apt to remain more uniform, and when fogs and rains are less likely to occur. A suitable interval of time should be observed in order that the first coat should be entirely and completely dry before the second coat is added. In order to have the painter or contractor observe this, and to make sure that more than one coat is put on, the several coats should differ slightly in color, so that such neglect would be readily determined and corrected.

In the purchase of materials, the preference should be given old and long-established houses, whose reputation for quality is well known, and it should not be expected that the purchase of paint materials at less than market prices will be conducive of anything but the practice of adulterating the products.

In the application of the paints, which should have been selected with considerable care, only experienced and reliable

mechanics should be employed; in the long run, besides their ability to spread a smooth and regular coat, their experience will save sufficient material, or make the same material go enough further, to warrant the employment of the skilled mechanic, if the selection of the individual is put upon a basis of first cost, rather than of comparative excellence.

Repainting.—Intelligent and systematic care should be given a structure continuously after painting, remembering that "an ounce of prevention is worth a pound of cure." Repainting should not be too long delayed, and at the first evidence of this necessity, the old paint should be carefully removed before the fresh covering is applied. In doing this, a strong caustic solution should be used to partially decompose the old film, and steel scrapers and wire brushes then employed to detach the coat. Immediately afterward, the metallic surface should be carefully washed down with water and dried, any deep-seated rust-spots or paint which it has been impossible to remove otherwise being burned away by the application of the flame from a painter's torch.

It stands to reason that the more care exercised in cleaning down to the metal, the better the results from the new paint coating to be applied, and the greater longevity of the metal.

In view of the constantly widening range of the use of steel for structural purposes, it is not surprising that constant effort should be directed toward determining the best protective coating for iron and steel. At a recent meeting of the Am. Soc. for Testing Materials, a committee report of much importance, presented by its chairman, Mr. S. S. Voorhees, is as follows:

"PROTECTIVE COATINGS FOR IRON AND STEEL.

"The membership of the committee has been increased from the original 6 to 17 members, and the committee has aimed to

include representatives of every class engaged in commercial production of protective coatings.

“ The three meetings of the committee held during the year have so far been confined to discussing the best methods of obtaining the desired data for a comprehensive report on this subject.

“ Before beginning this work it was considered necessary to put in concrete form several working headings:

“ 1. Requirements for a satisfactory protective metal coating.

“ 2. Methods used and suggested to determine if the protective coating is efficient.

“ 3. An index, with abstracts, if possible, of general and current literature bearing on this subject, which has appeared in English, French, German, and American publications.

“ 4. A classified list of all coatings used or suggested for the protection of iron and steel.

“ Sub-committees on the first two subjects have submitted reports; sub-committees on the last two subjects report progress and request further time for final report.

“ The report of the sub-committee on requirements for a satisfactory protective metal coating resulted in the following recommendations:

“ IN PREPARATION OF SURFACE FOR PAINTING it is considered necessary that surface be free from grease and dirt, and that all detachable mill scale and rust be removed. Material which cannot be removed by hammer and chisel or wire brush, it is thought, will not affect the durability of the coating. The use of the sand-blast is recommended, provided it is the opinion of the engineer that the cost is warranted, but it is not considered necessary in all cases.

“ APPLICATION OF THE PAINT.—It is recommended that the successive paint coatings should be as thick as possible, compatible with satisfactory spreading with the brush or machine. The brush marks should flow out. The paint should not con-

tain any large amounts of volatile matter, so as to chill the surface by evaporation.

“**DRYING.**—It does not seem possible without further experimentation to reach a final conclusion on this point. Whether the paint coats shall dry in six or twenty-four hours is a matter to be determined by the contingencies of the case. In general this recommended that as much time as possible be allowed between coats. It is, however, considered practicable to have an efficient metal coating dry in eight hours.

“**SUCCESSIVE COATINGS.**—The under coatings must not be softened or acted upon by the subsequent coats of paint.

“**PROTECTIVE POWER.**—This is the keystone of the whole subject. The coating must protect. To accomplish this it is recommended that the coating must have the maximum impermeability to moisture, air, and carbon dioxide. Iron and steel will not rust in dry air or in water free from air and carbon dioxide. The best protection will, therefore, be obtained from the most impervious coating. To this end the pigment should be as finely ground as possible; and, finally, it is recommended that the vehicle or pigment, or both, be water repellent. Whether this last characteristic is to be obtained by a pigment such as lamp-black, or by the use of some non-drying oil, must be the subject for further investigation.

“**DURABILITY.**—It is the opinion of the committee that coatings should be efficient under ordinary conditions for at least five years. The durability measures the life of the coating; it should therefore adhere to the metal through all ranges of contraction and expansion without peeling or cracking.

“Neither the pigment nor the vehicle, nor compounds resulting from a reaction of the two, should cause a disintegration of the coating.

“It is further recommended that the coating should not be affected by products necessary for the maintenance, equipment, or use of the structure protected. This applies especially to the

softening of paint on bridges by burning and lubricating oils from passing trains.

"It is finally recommended that the coating be of such a character as to successfully resist the mechanical injury due to sand, cinders, and other material carried by the wind.

"FEASIBILITY OF RECOATING.—There can be no question that a satisfactory coating must permit recoating when needed without additional labor for cleaning and removing old coat.

"COST.—Upon this point it is only necessary to say that the other valuable requirements being obtained, that coating is best which can be furnished and applied at minimum cost.

"SUB-COMMITTEE ON TESTS TO DETERMINE EFFICIENCY OF COATING.

"It is the opinion of your committee that it is useless to prescribe the same tests to all classes of protective coverings. An efficient coating in the dry atmosphere of the Western States may fail to withstand the moist saline air of the coasts. A coating which is perfect for structural steel under a static load may fail entirely when subjected to vibratory shock imposed on bridge members and steel cars. In short, tests must be in harmony with conditions imposed in service.

"The general cause of failure of coatings to protect is the same as the corrosion of the metal itself, i.e., moist air and carbon dioxide. Dilute acids, as a rule, have far less action on paint films than alkaline solutions. A paint made from some inert pigment and linseed oil will show no sign of disintegration when immersed for days in a dilute sulphuric-acid solution which would rapidly dissolve the metal it protected, and the same paint would go to pieces in a few hours when exposed to the action of a correspondingly strong solution of ammonia or carbonate or caustic alkalis. Strong acid solutions rapidly destroy the coating,

but it is rare that such conditions exist, and, if necessary, can be met by special requirements.

“It is recommended that tests be adapted to the demands of service conditions and divided into three broad classes:

“1. Actual service tests, under normal conditions, applied to structure to be protected.

“2. Accelerated tests, applied to specially prepared surfaces, and subjected to abnormally severe conditions.

“3. Chemical tests to determine the constituents and adulterations of the pigment and vehicle, as far as the knowledge of the subject will admit.

“It is undoubtedly true that the first set of tests gives the desired information in a most conclusive manner, but, unfortunately, the truth comes too late to remedy the evil if the protection is insufficient to prevent corrosion.

“It is further considered that the function of this committee is not to specify any covering or coverings as protective, but to specify tests which coatings must stand to assure maximum efficiency. It will therefore be necessary to work along the lines of accelerated and chemical tests, selecting those which harmonize with the results of long-time service experiments, and ultimately formulating laboratory tests which can be relied upon to give the desired information.

“It should, however, be realized that in this work chemical analysis must be used to supplement experience, not to provide it. In general, it is known by previous experiments that certain pigments and oils give durability and protection, while others fail in these essentials; but it will not do to condemn the unknown without the aid of experience.

“A review of the suggested accelerated tests shows a variety of methods to impose abnormally severe conditions. These tests have in some cases little connection to service requirements, but it is believed that the results obtained by the methods selected will be in harmony with long-time service tests.

“ It is expected that the following series of experiments can be conducted through the cooperation of railroads and consumers on one hand, and the manufacturers of standard coatings on the other, the former to provide the structure and labor and the latter the material to be applied:

“ It is recommended that two coats of the protective coating be applied to parts of full-sized structures, not less than one span of a bridge, one steel freight-car, or, in general, one unit of dimensions corresponding to above, the surface to be prepared and coating to be applied as recommended under those headings.

“ At the same time, panels of tank steel $20 \times 24 \times \frac{1}{4}$ in. are prepared and coated in the same manner as the structure and with the same batch of coating. The panels are coated on both sides and on edges of sheet. The work to be done indoors under favorable conditions for drying.

“ The panels are to have a $\frac{1}{4}$ -in. hole bored in middle of upper end to facilitate hanging, and are to be stamped with serial number on both sides in upper left-hand corner.

“ Panels are prepared as above in pairs, one to be exposed ‘green’ and the other to be thoroughly dried under favorable conditions before testing. The corresponding pair of ‘green’ and dry panels are exposed under the roofs of train sheds, in roundhouses directly over smoke-stacks of engines, from trusses of bridges, on roofs of train sheds, roundhouses, and on roofs adjoining power-house stacks, etc., in tunnels, on docks in salt water and tidal rivers, where they will be immersed twice every twenty-four hours in salt and fresh water in the ebb and flow of tides.

In addition to above series of field panels, special laboratory panels on glass and tank steel are prepared in the same manner as the foregoing. The steel panels are exposed to the action of exhaust steam at a temperature not to exceed 150° F. for

twelve hours each day, and ordinary atmospheric air for the remaining twelve hours, the test to be continued for thirty days.

“The porosity is determined by noting the absorption of a drop of oil on the coating. If the film is impervious, the drop of oil will run down the panel in a narrow band the width of the original drop, but if the life of the coating has been destroyed the drop of oil will spread out to a more or less greasy blotch, depending on extent of disintegration.

“The glass panels are tested for water-repellent properties by treating the dried coating with a few drops of water. Evaporation is prevented by means of a cover-glass, and the coating examined after the water has been in contact for twelve hours.

“The capacity of the coating to withstand destructive agencies necessary to equipment and maintenance of structure will require special tests.

“For steel cars and bridges the coating on glass is tested with lubricating and burning oils to determine if it is disintegrated. For refrigerating-cars it is tested in the same manner with a common salt solution.

“A further set of laboratory tests are made by coating saucers of sheet iron 8 inches diameter 1 inch deep with two coats of paint. These saucers are filled with ordinary tap water and allowed to evaporate under cover to dryness, the water renewed until definite conclusions can be deduced.

“Chemical analyses of the coatings will also be made to determine percentage of pigment, oil, and volatile matter, with composition and quality of each.

“The above service and laboratory tests are to be conducted at as widely distant points and under as different conditions as possible. The service tests are to be carefully examined at stated intervals and the entire series of experiments accurately tabulated for comparison with the long-time service tests.

“From these data it is expected that laboratory tests can be

formulated which, when met, will insure a satisfactory protective metal coating."

The quantity of any paint to cover a given surface will depend upon the smoothness, absorption of the surface and also upon the fluidity of the mixture.

A finely ground pigment with linseed-oil as a medium will ordinarily cover about 600 square feet one-coat or 350 square feet of two-coat work. A capable painter should, during a day of eight hours, spread about 800 square feet of flat surface and about half as much over structural work. The latter will average for light work about 250 square feet per ton of metal. \$2.50 per day may be taken as fair wages for a competent painter.

The following gives the

AVERAGE SURFACE COVERED PER GALLON OF PAINT.

Character.	Volume of Oil.	Lbs. of Pigment.	Volume and Weight of Paint.		Sq. Ft. 1 Coat.	2 Coats.	Cost per Gal. Mixed.
			Gals.	Pounds.			
Red lead (powdered)...	1 gal.	22.40	1.4...	30.40	630	375	\$1.50
Graphite (in oil).....	1 "	12.50	2.0...	20.50	360	215	1.00
Black asphalt	1 "	17.25	4.0...	30.00	515	310	0.90
Asphaltic varnish.....	1 "	1.0...	8.00	400	300	1.50
Pure linseed-oil.....	1 "	875	...	0.50

CHAPTER XII.

SHOP-PRACTICE AND ERECTION.

Laying Out Work.—As soon as the metal sheets or plates for tank or stand-pipe work are received at the shop, they should be immediately and carefully unloaded and stored awaiting the earliest moment when they may be “laid out.” This process consists in marking off the plates for shearing, machining, punching, and rolling.

The object of shearing or machining is to put a bevel-edge upon the opposite face of the plate where two plates are to be in contact, and in order that the thin edge so formed may be properly and easily calked after riveting and that a water-tight joint may thus be secured.

For the reason that such work upon heavy plates has been shown to exert a force tending to change the molecular arrangement of the metal, this shearing of plates is usually not permitted upon plates that are thicker than $\frac{3}{8}$ of an inch, all plates above that thickness being planed to a bevel by a machine.

In laying out, the rivet-hole spacing is indicated by marking with a sharp-pointed cold-chisel, the widths from centre to centre, or the pitch, having first been calculated as has been described and explained.

Realizing that a greater comparative efficiency of joint-strength may be secured, with fewer rivets and wider spacing, where the largest possible rivet is used, this inclination is sometimes stretched to the limit, the requirement for tight-

ness of joints, as in stand-pipe work, being considered as having been provided for in the natural tendency of such joints to close by rusting after erection, and to what extent this practice is considered legitimate may be inferred from the following, taken from an article on painting, and from Prof. Pence's work, "Stand-pipe Accidents and Failures": "The methods of painting stand-pipes are subject to as much variation as in other exposed structural metal-work. Some require that the inaccessible surfaces shall receive two coats of red lead, while others allow the omission of paint from the faying surfaces of the seams to permit the joints to rust."

Again, according to recognized authorities, in forging a rivet, the color, indicating its temperature, should be about an orange red, and with steel rivets, with a tendency to rapid cooling, at this temperature the larger rivets, especially hand-driven, are so cold and tough before they are driven completely home and the head forged, that it is difficult to insure a perfect filling of the rivet-holes, and the requisite closeness of the joint, where rivets of large diameter are used, and for which reasons, in preparing the table given in the chapter on Riveting, these considerations were given weight. In the mention of this table, it may not be out of place here to refer to the dimensions and relative strength of the double-butt strap-joint, and to point out that while fully recognizing that the full strength of such a joint has not been developed, the necessity for such excess strength over and above all the other joints, both single, double, and treble riveted, did not seem necessary or particularly desirable.

Machining: Punching and Rolling.—After the plates are laid off and bevelled, the punching of rivet-holes should be done, and away from the surfaces to be in contact. Plates not exceeding $\frac{5}{8}$ inch in thickness may be punched with sharp and well-conditioned punch and dies, either singly or preferably by a power-machine employing several such

punches or dies, properly spaced. The area of the rivet-hole should be about $\frac{1}{16}$ inch greater than that of the rivet proposed to be used.

Plates having a thickness between $\frac{5}{8}$ and $\frac{7}{8}$ inches should be punched $\frac{1}{16}$ inch less, and reamed out; while plates over that thickness should be drilled from the solid sheet.

While it has been shown that for tank work, plates, regardless of thickness, can be connected in a more mechanical fashion by requiring the horizontal seams to be a lap and the vertical joints a strap connection, for reasons of economy, the lap-joint is used and will probably continue in use for connecting all plates, for both horizontal and vertical seams, where the thickness of the plates are less than $\frac{1}{2}$ inch, and possibly a thickness of $\frac{13}{16}$ inch should be considered as the maximum permissible thickness for the use of a lap-joint. In order to make the lap-connection, a corner of the plate has to be heated and drawn out to make the joint where three plates come together. This drawing out after heating is called "scarfing," and is objectionable, both on account of the unmechanical joint produced and as well as from the fact that this reheating and working of the steel reduces its strength, as has been explained in the chapter on the Physical and Chemical Properties of Steel.

When, from reasons of economy or other necessity, this reheating is permitted, that it may be as little objectionable as possible, it is recommended by authorities that the temperature of the metal, and which permits working, shall range between a heat which will ignite hard wood and the boiling temperature of water. In flanging or other bending, it is sometimes necessary to work over the metal in this way, but for bending sheets and angles to radius for tank work, heating is not necessary and should not be allowed, it being entirely possible to bend the metal to the required shape

when cold by passing it through powerful steel rolls; this is called "cold-rolling," and should always be specified.

Such rolling should invariably follow the work of beveling and punching, better results being obtainable through such process.

Shop-assembly.—Immediately after rolling, the various separate parts of the structure should be assorted and "assembled," to insure a fair and satisfactory arrangement at the point of erection. Where the rivet-holes do not match perfectly in the assembled parts, the rivet-holes should be made to coincide and any eccentricity should be corrected by reaming out the hole and providing for a larger rivet.

After testing the several members during this "shop-assembly," each piece should be regularly and carefully marked, that no confusion may result at the time of "field" or final assembly.

Cleaning and Priming.—Immediately after testing and correcting the shop-work, the parts should be carefully cleaned of all dirt, grease, mill-scale, or rust, as has been explained, preferably by the use of the sand-blast, after which, as has been suggested, a coating or priming should be made with red lead, lampblack, and linseed-oil, and as soon as sufficiently dry for handling, the material should be carefully loaded into the cars, and consigned to the point of erection.

This class of work as above described is usually done by any well-equipped boiler-works, and the shop-cost is about \$20.00 per ton, exclusive of painting.

During the progress of the work, independent shop-inspection should be insisted upon and carried out by an experienced and reliable inspector whose fee would amount to approximately 40 to 50 cents per ton of material, or about \$1.00 per ton for complete inspection and test at both mill and shop.

Angles and other shapes, intended to form such a superstructure as a tower, are usually sheared, milled, and connected by riveting at a well-equipped bridge-works. The same precautions as to riveting and cleaning should be taken as with the tank work, and surfaces in contact and thereafter inaccessible should be given at least two coats of red lead and oil. Only connections should be made in the field, all other parts being riveted in the shop before shipment.

Preparation of Foundations.—To avoid what is known as “green masonry,” as far in advance as possible before “field-work,” the foundation masonry should be laid. The site of the structure having been determined, careful tests should be made to determine the character of the soil and to ascertain its bearing value. Such tests may be made by driving test-pits with such an implement as a post-hole digger, or by borings made with an auger of not less than 2-inch diameter. The auger-bit is welded into a short section of pipe; another short section is fitted with a cross-piece or handle, and additional sections, having suitable couplings, are to be prepared in sufficient number to permit the borings to be carried to a safe and satisfactory depth. As soon as expedient after such borings, and the design of a foundation to support the structure, excavations are made and the subfoundation or bearing prepared. The character of the connections for the anchorage having been designed, flat planks or boards should be connected in such a way as to form a suitable templet, which should be carefully laid off and holes of proper size bored. The anchor-rods having been provided, these are usually enclosed in old boiler or other tubes, slightly larger than the anchor-rods, and of approximately the same length or a little shorter.

The rods and tubes are inserted into the holes of the templet, which is then raised to the correct height or level and made fast with wooden props or stays. Each of the

washers of the rods are then carefully levelled and the rods plumbed, generally with a line and bob, after which the masonry is commenced and continued to completion, the tubes remaining in place until that time, when they are withdrawn, leaving a space about the anchor-rod, which allows slight adjustment of the rod to suit the connection when placed.

Upon the completion of the masonry, the templet and braces are removed, the rods tested and adjusted, and the spaces about them filled with cement grout, as thick as can be poured.

All series of levels taken should be carefully recorded, and should refer to a permanent "bench-mark" or datum. In this way, any irregularity during construction may be corrected and any subsequent settlement may be noted.

In the foundations for the usual tower, the templet for the rods and tubes is generally formed of a single plank, thick enough to prevent sagging, and which is accurately placed across the foundation-pit, buried flush with the earth, and frequently fastened or staked down to prevent disturbance. The rods are passed through suitable holes bored in this plank, levelled and plumbed. It is hardly necessary to remark that each of these foundation-pits require a separate plank.

Preliminaries to Erection of Stand-pipes.—The foundations being ready to receive the superstructure, provision should be made for carefully unloading the material upon its arrival, for which purpose, ordinarily, a short "gin-pole," with a metal hook or rope sling at its top, and guyed in a vertical position and adjacent to the transfer track is found convenient.

Great care should be taken to prevent bending any of the sections or rubbing or scratching the surface which should have been primed.

Arrived at the foundations, the sheets should be systematically placed, the bottom pieces and angles being nearest; the top pieces, cresting, etc., furthest away from the foundations.

Upon the top or face of the foundation, it is customary to place the kegs of rivets, which being of the same height, make a sort of platform upon which the bottom plates may be put together.

After these have been riveted to each other and to the circumscribing angles which fasten the bottom and shell, the tightness of the bottom is tested by pouring water upon the plates. If the joints are not found to be tight, they are further calked, or if the leak is due to imperfect or loose riveting, such rivets are cut away with chisel and sledge; the hole is reamed larger and a larger rivet inserted and driven.

Field-assembly.—These preliminaries having been observed, about the outer circumference of the foundations a slight, low dam of clay puddle or even of sand is constructed; into the area so formed is then slushed or poured a rich cement grout, sufficient to cover the face of the foundations and deep enough to entirely cover and hide the heads of the rivets upon the under side of the bottom plates. Having been quickly “floated” or levelled over, the bottom of the tank is lowered as rapidly as possible, by means of jacks or levers.

The separate sheets of the first ring are then set in position, being temporarily bolted to place and afterwards riveted.

As each sheet is placed, the surfaces in contact, or the joint surfaces, should be given another coat of thick red lead and oil, as should also the joint after riveting, that the rivet-heads may be entirely covered to prevent the formation of rust during construction and before the finishing coats of paint are supplied.

With the second and succeeding rings, a short "gin-pole" is first bolted to the top rivet-holes of the section below, and sheets are hoisted in succession and temporarily fastened with bolts until the entire circle has been so placed, when riveting is begun, the heating-forge being conveniently located in a travelling-carriage or "cage," moving along the circumference upon small rollers or trolleys as required, while the riveter, forming the field-heads with a forming-hammer, upon the head of which two men strike with sledges, remains upon the inside of the structure, all the workmen standing upon scaffolding, which is raised as the work proceeds, and which may consist of 2" X 2" uprights.

Upon the completion of the metal-work of the shell, the ornamental cresting or cover, the ladders and other fittings and trimmings are put in position; the tank then being ready for testing, is filled with water. Leaks along the seams are caulked carefully, but no caulking should be permitted upon leaks about rivet-heads, due to imperfectly-filled rivet-holes or loose rivets. Such rivets should be cut out with chisel and sledge; the hole reamed out and larger rivets driven. Such leaks are carefully marked while the water is in the tank and the repairs made after the vessel is emptied. No caulking or chipping should be allowed while the water remains in the tank. The hoisting of plates is usually done by hand, using a winch, from which a line passes through a block hung from a loop or hook on the "gin-pole," and to which is attached some form of tongs or "grab," which may be hooked into the rivet-holes of the sheet to be hoisted. A "riveting crew," or gang, consists usually of a foreman, who also personally does the caulking of seams; a riveter, generally an experienced boiler-maker; a skilful "heater," who heats the rivets to a forging heat and passes them in tongs into the rivet-holes, and three laborers, one of whom directs a heavy suspended weight against the rivet being

driven, while the other two strike in turn upon the hammer held by the riveter in forming the field-head. Two extra laborers are generally employed to work at the winch and to sort out material as directed by the foreman.

Such a crew will drive from 400 to 500 rivets per day of ten hours, at a cost of 3 cents each, or the entire cost of erection, including riveting, will amount to about \$20.00 per ton of material. The scaffolding is left in place upon the inside of the tank until after testing by filling. The tank being tight, it is then removed. Instead of the scaffold as described, a floating scaffold is sometimes employed, which consists of a buoyant platform or float that is raised to position as required by pumping water into the tank.

Inspection.—After inspection and approval of the metal-work and the emptying of the water used in testing, the interior surfaces should be wiped dry with oily cloths, and the final coating or painting given, the scaffolding being removed as the painting proceeds from the top downward. In view of the fact that a heavy gale is liable to seriously affect the joints of the stand-pipe if empty, by straining the structure, immediately upon the drying of the paint, the reservoir should be filled with water and kept so filled until put into actual use as part of the water system.

Erection of Towers and Tanks.—In the erection of a tower, the pedestal-plates should be bedded in cement mortar about an inch thick. The first step toward erection is to conveniently place the columns and members of the first panel or section, and in such position that, with the aid of a stout gin-pole, blocks, tackle, and winch, the columns may be simultaneously raised to their vertical position and the horizontal members placed and temporarily fastened with bolts, to be subsequently riveted before proceeding with the next panel or deck.

As has been remarked, the field-riveting should be con-

fined entirely to panel-points or points of connection, all other rivet-work having previously been done at the shop.

The first panel having been secured, a smaller gin-pole is bolted to each of the columns or legs in succession, and the next vertical member is raised to its place and fastened by bolts until all of the column-sections are so located, when the horizontal and diagonal members are hoisted into position and secured. When the last or upper panel is in place, where the structure is surmounted with a platform, this is erected, from which work conveniently proceeds upon the girders, bottom, and subsequent tank-sections or rings, as has been described.

An approximate cost of such work is \$25.00 per ton of material, varying with the local conditions at the point of erection.

Field-riveting and Machine-driven Rivets.—As the field-work consists largely of riveting the members together, the following, taken from the *Locomotive*, a paper published by the Hartford Steam-boiler Inspection and Insurance Company, may be of interest: “The driving of rivets is such a comparatively simple operation, that it might be supposed that it would be almost always well done. This is far from being the fact, however, and bad riveting is one of the commonest defects reported by our inspectors.

“The rivets may be too short, or too long, or too small; they may have heads that are too flat, or they may have projecting ‘fins,’ or they may not fill the holes, or the holes may not come ‘fair’ with one another. There are many ways in which riveting may be bad. . . .” In reporting a particular case of imperfect rivet-work in the same article, is the following: “The inspector found the rivets ‘driven very low’—that is, the heads were entirely too flat. He had a number of these rivets taken out, and found that the holes in the two sheets did not come opposite one another fairly. This

defect is a common one, and it is very serious, both because it reduces the shearing-area of the rivet, and because it greatly increases the difficulty of making the rivets fill the holes perfectly. A shop that turns out work of this kind is particularly censurable, not only because the work itself is poor and weak, but also because the defect is not easy to discover, after the rivets are in place, and the owner of the boiler is therefore likely to be deceived by a fair external appearance, and to carry more pressure than the boiler can safely withstand. The inspector also found that the heads were not driven evenly over the holes, the centres of the heads often lying well towards the side of the rivet. This defect, although not so dangerous as the unfairness of the holes, would not be tolerated in a good shop having any pretense of turning out first-class work. It is very easily detected, even by one who has had little experience in inspecting; and there is no excuse for it whatever. . . . The only thing that could be done in the way of improvement would be to cut out all the rivets, ream out the holes until they should be true, and rivet them up again with larger rivets."

There are many reasons for the belief that a machine-driven rivet makes a much more satisfactory job than where a rivet is driven by hand, for the metal cooling rapidly, the greatest power and certainty is required to forge the head before the rivet material is too cold to work. Various types of power riveting-machines are now built whose motor force is either air, steam, water or electricity, affording a constant pressure throughout the stroke of about 80 pounds.

From comparative tests with both power- and hand-driven rivets, in Kent's "Mechanical Engineer's Handbook," is recorded the slip of plates pulled apart. In this it is shown that machine-driven rivets of equal diameter held twice as much as hand-driven rivets.

At the Gas Exhibition, held in New York about 1897,

samples of heavy plates riveted by both hand- and machine-work were split with a saw, and the rivets and holes shown in cross-section. All machine-driven rivets completely filled the rivet-holes, while the hand-work was seen to be very irregular. In his work entitled "Iron Highway Bridges," and in connection with suggestions for riveting, the following is given by Mr. Alfred P. Boller, M. Am. Soc. C. E.: "Power-riveting is so superior in all respects to hand-riveting that a higher unit of strain, by probably 10 per cent., can be used under the former system; so that if it is considered proper to strain hand-rivet work up to 13,500 lbs. per square inch, work riveted up by steam or hydraulic power can be safely proportioned on a basis of 15,000 lbs. per square inch."

So clearly is the superiority of power-riveting, that it is specified almost exclusively for boiler-work, bridge-work, and in fact for almost all shop-work, but its use in the field is comparatively limited and of recent date. In this connection, the *Engineering News* for May, 1895, publishes a description of a stand-pipe erected at St. Barnard, by L. Schreiber & Sons Co., of Cincinnati, Ohio, who used for the field-work a pneumatic riveting-machine, suspended from a hoist by the arm of a crane with mast in the centre of the shell. In response to an inquiry as to this work and as to the cost and efficiency of power field-riveting in general, Messrs. Schreiber & Sons Co. reply "that we have found pneumatic riveting much better than hand-work, especially so if the machinery is of the proper kind. We do this work under very high pressure and hardly believe (owing to the fact that the machinery required for this work is very heavy) that there is a great saving over hand-riveting. However, there is a little in favor of the machine-riveting."

The Logan Iron Works, contractors for a stand-pipe at College Point, L. I., used a pneumatic riveting-machine in driving some 75,000 rivets. According to information re-

ceived from the manufacturer of this machine, "not a single rivet had to be cut out or caulked, a most exceptional record which has not been equalled by any other machine. They drove 800 to 1200 rivets per day, depending on size. They tell me the cost of driving by machine was less than half that of driving by hand. Allowing three men and a boy on machine, at \$9.00 per day and \$4.50 for cost of running air-compressor and fuel, or \$13.50 per day for crew, this makes a cost of about one to one and a half cents per rivet."

A quotation from a communication to the *Engineering News* from Mr. Freeman C. Coffin, M. Am. Soc. C. E., will be used in concluding this subject, and is as follows: "The rivets should be driven by steam or hydraulic power. This may seem radical, but I do not think so. I see no real reason why it could not be done with the suitable appliances. If field-riveting can be done by power in any structure, a stand-pipe is the best form, as there are continuous rows of rivets of about the same diameter, and the only especial form of appliance would be the yoke of the riveter, which would need to straddle a 5-foot plate. I do not believe that this is impracticable. I think it must hurt the feelings of any engineer to see two men with heavy sledges pounding away at a cool rivet, endeavoring to form a head on it. The usual result is a very thin, flat head, as the rivets are used as short as possible in order not to cause too much trouble if they happen to get cold before they are finished."

CHAPTER XIII.

SPECIFICATIONS.

NECESSARILY the briefest allusion to and the faintest outline of the fundamental principles of engineering jurisprudence, or the law of contracts for constructive work is possible or allowable here.

Usually the construction of metallic reservoirs are incident to the building of entire systems of water-works for municipal supply, and the general agreement governing such construction and incorporated into the forms of a contract apply equally to this particular item of the whole work.

Suitable forms of agreement are dictated by the necessities and the general understanding of the particular case, covering in a general way the character of the work to be performed, whose details are more fully set forth and particularly described through the wording of the "specifications." As the draft of such an instrument as a legal contract for important work, such as the construction of a water system, falls frequently to the lot of the professional legal adviser, requiring of the engineer simply the technical description or the specifications intended to govern the constructive work, no analysis will be attempted of the forms of contract and recognized procedure in such cases; but since it is the province and duty of the engineer to prepare plans and to describe in detail the technical features of the work, and as the incorporation of the principles and practices heretofore enunciated in the preceding pages is undoubtedly pertinent and proper, a general form and brief discussion of the specific

requirements intended to govern the construction of a structural steel tower and tank are hereinafter included. Inasmuch as metal, design, and workmanship prescribed are applicable generally as well to such structures as stand-pipes, separate specifications for the latter type will be omitted.

Municipalities, corporations, or individuals, called upon to perform constructive work of magnitude and importance, seldom undertake its execution, necessarily relying upon skilled mechanics and artisans employed and controlled by individuals of practical and financial ability, who, for adequate consideration, undertake to perform the work required within a stated time. This undertaking is generally expressed in a written instrument of agreement known as a contract and the work is performed under the penalty expressed in a bond.

An essential element of a valid contract is that there be a perfect and well-defined understanding and mutual consent between the parties. The usual manner of reaching a mutual understanding, especially when the character of the work contemplated is of considerable magnitude, and its execution requires technical training and experience, is by invitation, public or private solicitation, as by advertisement for proposals, which negotiations, conducted by municipalities or individuals, carry with them the right of creating, completing, and determining a contract through the unreserved acceptance of one of the proposals solicited when made in absolute and unconditional terms.

Often the requirement of a statute makes the form of invitation or advertisement mandatory; describes what degree of publicity shall be necessary, and in such cases any violation of the legal terms are fatal to the validity of the contract.

In order that free and fair competition be secured and that favoritism, collusion, combination, and fraud be minimized, statutory acts generally prescribe due notice by advertisement of the intent of the municipality to enter into a contract for a specific purpose; frequently the form of advertisement is ex-

plicitly indited, stipulating such general information as may be deemed sufficient for the notice and guidance of prospective bidders and stating the formalities incident to the proposal.

To obtain reasonable, fair, and intelligent competition is the legitimate object of all such advertisements for proposals, to secure which it is imperative that the relative value of all offers be submitted to scrutiny and comparison upon precisely the same terms; hence it becomes the duty of those authorized to conduct such negotiations to cause to be prepared, either graphically, by descriptive phraseology, or both, what is technically and respectively known as "the plans" and "specifications" to be used primarily for the information of bidders, and eventually to be incorporated into the body of the contract expressing the mutual obligations of the contracting parties.

In drafting a contract it is necessary to the integrity of the instrument that the exact understanding of the parties to the agreement should be stated in precise terms; ample provision must be made not only for present conditions, but to cover future emergencies or contingencies, while the technicalities of the law must be strictly followed and adhered to throughout. Hence, as has been said, in important contracts it is usual to entrust the preparation of such instruments to legal advisers, while necessarily, in constructive contracts, engineering details are left to the engineering expert, the collaboration frequently resulting in errors, misunderstandings, and discrepancies between the terms of the contract and the intent of the specifications.

In cases of resulting differences, the intent of the parties will be sought and established if possible, but in the absence of conclusive evidence as to what was meant, the contract itself is of the first importance, as it represents the instrument by which the obligation to perform the work or to furnish the material is assumed, and there is a tendency to give greater weight to it than to the plans and specifications which are chiefly descriptive of the work and the manner of its performance and which are almost

always subject to change or modification. It is possible that the secondary place given the specifications where litigation has arisen may be due to the fact that the court necessarily is more familiar with the law of contracts than with the mechanics of engineering. However, a little care in drafting a contract, including specifications, will prevent inaccuracy or ambiguity.

While the exact intent of the parties should be understood and carefully and accurately incorporated into the body of the contract through its phraseology, the terms of the specifications, while intended as a collateral and integral part of this instrument, should be exact in meaning and expression, but not necessarily minute as to detail, as unnecessary refinement is more likely to lead to confusion and misunderstanding than to clear comprehension.

Whilst generalities should be scrupulously avoided, specifications should be so drawn that a broad treatment and interpretation of the particular matter should be possible, as results, regardless of specific limitations and narrow exactions, should be attempted, and in almost any specific case a greater success will undoubtedly be secured by permitting individuality and a certain latitude in the design and execution of the particular work.

This freedom for individual expression should not be so licensed as to prove embarrassing in allowing competition along lines where comparison is impossible and relative merit indeterminate, nor yet such as would offer a premium or lead competitors, in the keenness of commercial rivalry, into experimental practice to an extent where failure would prove disastrous unless the responsibility for such failure has been discounted in advance and the liability for a possible disaster has been clearly placed where it properly belongs—upon the promotor or experimenter. In the preparation of the specifications for structural work no deviation from a high and comprehensive standard as to the quality of the materials and workmanship should be permitted,

encouraged, or made possible; but, as has been said, the general instructions should be such as would encourage individuality of design and construction, where such latitude is likely to elevate and cannot possibly lower the scale of general excellence sought.

What has been said presents rather the legal than the commercial aspect of a draft of a set of specifications, but beside the legality of the transaction, vital though this be, the technical and trade elements are primarily the most essential. The rule that "the best is the cheapest in the end" has its limitations. For a building, to specify all "hard" brick and "heart lumber" entails upon the purchaser an unnecessary expense where, in general, "kiln-run" brick and "merchantable" lumber would answer every practical requirement; nor should the engineer expect to get high-grade materials for his client by ambiguity and his interpretation of the specifications.

Before commencing to draft specifications, what is wanted must be fully known, expressed without ambiguity and useless verbiage, and afterwards insisted upon.

In a recent address, delivered before the American Society for Testing Materials, Dr. Chas. B. Dudley, Chief Chemist of the Pennsylvania Railroad Company, crystallizes these principles in his conclusions, which are as follows:

"(1) A specification for material should contain the fewest possible restrictions consistent with obtaining the material desired.

"(2) The service which the material is to perform, in connection with reasonably feasible possibilities in its manufacture, should determine the limitations of a specification.

"(3) All parties whose interests are affected by a specification should have a voice in its preparation.

"(4) The one who finally puts the wording of the specification into shape should avoid making it a place to show how much he knows, as well as a mental attitude of favor or antagonism to any of the parties affected by it.

“(5) Excessively severe limitations in a specification are suicidal. They lead to constant demands for concessions, which must be made if work is to be kept going, or to more or less successful efforts at evasion. Better a few moderate requirements rigidly enforced than a mass of excessive limitations, which are difficult of enforcement, and which lead to constant friction and sometimes to deception.

“(6) There is no real reason why a specification should not contain limitations derived from any source of knowledge. If the limitations shown by physical test are sufficient to define the necessary qualities of the material, and this test is simplest and easiest made, the specification may reasonably be confined to this. If a chemical analysis or a microscopic examination, or a statement of the method of manufacture, or information from all four, or even other sources, are found useful or valuable in defining limitations, or in deciding upon the quality of material, there is no legitimate reason why such information should not appear in the specifications. Neither the producer nor the consumer has a right to arrogate to himself the exclusive right to use information from any source.

“(7) Proprietary articles and commercial products made by processes under the control of the manufacturer cannot, from the nature of the case, be made the subject of specifications. The very idea of a specification involves the existence of a mass of common knowledge in regard to any material, which knowledge is more or less available to both producer and consumer. If the manufacturer or producer has opportunities, which are not available to the consumer, of knowing how the variation of certain constituents in his product will affect that product during manufacture, so also does the consumer, if he is philosophic and is a student, have opportunities, not available to the producer, of knowing how the same variation of constituents in the product will affect that product in service, and it is only by the two working

together, and combining the special knowledge which each has, that a really valuable specification can be made.

“(8) A complete workable specification should contain the information needed by all those who must necessarily use it, in obtaining the material desired. On railroads this may involve the purchasing agent, the manufacturer, the inspector, the engineer of tests, the chemist, and those who use the material. A general specification may be limited to describing the properties of the material, the method of sampling, the amount covered by one sample, and such descriptions of the tests as will prevent doubt or ambiguity.

“(9) Where methods of testing or analysis or inspection are well known and understood it is sufficient if the specification simply refers to them. Where new or unusual tests are required, or where different well-known methods give different results, it is essential to embody in the specification sufficient description to prevent doubt or ambiguity.

“(10) The sample for test representing a shipment of material should always be taken at random by a representative of the consumer.

“(11) The amount of material represented by one sample can best be decided by the nature of the material, its importance, and its probable uniformity, as affected by its method of manufacture. No universal rule can be given.

“(12) The purchaser has a right to assume that every bit of the material making up a shipment meets the requirements of the specification, since that is what he contracted for and expects to pay for. It should make very little difference, therefore, what part of the shipment the sample comes from or how it is taken. Average samples, made up of a number of sub-samples, are only excusable when the limits of the specification are so narrow that they do not cover the ordinary irregularities of good practice in manufacture.

“(13) Retests of material that has once failed should only

be asked for under extraordinary conditions, and should be granted even more rarely than they are asked for, errors in the tests of course excepted.

“(14) Simple fairness requires that when it is desired that material once fairly rejected should nevertheless be used, some concession in price should be made.

“(15) Where commercial transactions are between honorable people, there is no real necessity for marking rejected material to prevent its being offered a second time. If it has failed once, it will probably fail a second time, and if return freight is rigidly collected on returned shipments the risk of loss is greater than most shippers will care to incur. Moreover, it is so easy for the consumer to put an inconspicuous private mark on rejected material, that it is believed few will care to incur the probable loss of business that will result from the detection of an effort to dispose of a rejected shipment by offering it a second time.

“(16) All specifications in actual practical daily use need revision from time to time, as new information is obtained, due to progress in knowledge; changes in methods of manufacture, and changes in the use of materials. A new specification—that is, one for a material which has hitherto been bought on the reputation of the makers and without any examination as to quality—will be fortunate if it does not require revision in from six to ten months after it is first issued.

“(17) In the enforcement of specifications, it is undoubtedly a breach of contract legitimately leading to a rejection if the specified tests give results not wholly within the limits, and this is especially true if the limits are reasonably wide. But it must be remembered that no tests give the absolute truth, and where the results are near, but just outside of the limit, the material may actually be all right. It seems to us better, therefore, to allow a small margin from the actual published limit, equal to the probable limit of error in the method of testing employed, and allow for

this margin in the original limits when the specifications are drawn.

“(18) Many producers object to specifications on the ground that they are annoying and harassing, and really serve no good purpose. It is to be feared that the complaint is just in the cases of many unwisely drawn specifications. But it should be remembered that a good reasonable specification, carefully worked out, as the result of the combined effort of both producer and consumer, and which is rigidly enforced, is the best possible protection which the honest manufacturer can have against unfair competition.

“(19) Many consumers fear the effect of specifications on prices. Experience seems to indicate that after a specification has passed what may be called the experimental stage, and is working smoothly, prices show a strong tendency to drop below figures prevailing before the specification was issued.

“(20) A complete workable specification for material represents a very high order of work. It should combine within itself the harmonized antagonistic interests of both the producer and the consumer, it should have the fewest possible requirements consistent with securing satisfactory material, should be so comprehensive as to leave no chance for ambiguity or doubt, and above all should embody within itself the results of the latest and best studies of the properties of the material which it covers.”

Unfortunately the design and construction of water-towers has not always proceeded along lines identical with the principles stated.

Departure from the rules of good practice may, in certain cases, be attributed to dishonest motives, but it is very certain that in the large majority of cases, failure to make proper provision for such constructive work has arisen largely through ignorance both of the requirements of the structure and of its constructive material and workmanship.

As has been said, the inability to procure definite and reliable

information as to what does constitute a proper practice is undoubtedly largely responsible for this condition of affairs.

From the theories and suggestions preceding, the following represents in a general form

SPECIFICATIONS FOR A STRUCTURAL STEEL WATER-TOWER.

GENERAL DESCRIPTION.

The structure will be located..... The reservoir shall be a cylindrical shell.....feet in diameter andfeet high, to be constructed of steel plate, riveted together, with joints breaking vertically.

The supporting tower must have a vertical height from capstone to circular girder of feet, and shall consist of (No.)steel supporting columns, divided into (No.).....stories or panels; each panel shall include horizontal struts and diagonal tension rods.

Columns shall be straight throughout, and incline from the vertical.....feet in.....feet (or column sections shall be straight between panel-points, representing chords of a circle to radius of.....feet. Located tangent to the vertical lines of the tank, and upon the arc of the circle, substantial junctions shall connect columns; horizontal struts and diagonals).

Along one of the columns there shall be securely riveted at appropriate intervals a substantial steel ladder, extending from a point.....feet above the capstone to opening in the balcony floor.

Each column shall terminate in a suitable pedestal and shall be supported upon a.....(character of stone) capstone, to be properly bedded in cement mortar upon a substantial concrete (or.....masonry) pier. Anchorage must be provided.

With each proposal there must be submitted a stress diagram showing stresses to which members are subjected and dimensions proposed. After award of contract, but before materials have been ordered, working drawings in detail shall be submitted to and shall receive the approval in writing of the engineer.

COVER.

Surmounting the shell and secured thereto by angular steel connections, a conical (or pagoda) steel-plate cover shall be constructed. Its height shall be.....feet above the top of the cylinder, and its apex shall terminate in a conical steel-plate cap (or ornamental galvanized finial). The cover-plate shall project.....inches beyond the vertical lines of the shell, forming thereby an eave, terminating with a circular angle connection, between which and the shell shall be secured to the cover a... by.....inch deep fascia plate, with ornamental border (or for fascia plate describe galvanized cornice). At a point at the top of the shell an opening....by....inches shall be provided, reinforced with suitable angles about its under side and supplied with double steel doors securely hinged.

LADDER.

Downward from the metal doors, for a length offeet, a steel ladder, secured to the shell at proper intervals, and capable of sustaining not less than one thousand (1000) pounds, shall be provided.

PAINTER'S TROLLEY.

.....inches below the top of the shell there shall be firmly riveted a steel shape suitable for the support of a painter's trolley.

CIRCULAR GIRDER.

The cylindrical shell shall terminate in a continuous steel plate girder, its lowest ring forming the web, to be not less thaninch thick, and to which angles forming

horizontal flanges shall be riveted. The web shall be stiffened at appropriate intervals by vertical angles or other approved shapes riveted thereto.

BALCONY.

At some convenient point about the circular girder there shall be constructed a balcony, with floor of segmental steel plate, not less than.....and.....inches wide, supported by steel brackets, so spaced and riveted to the girder as to form a substantial support for at least five thousand (5000) pounds concentrated load.

At a point over one of the tower columns an opening.... inches by....inches shall be made and reinforced by suitable angles about its upper sides.

At safe intervals upright steel shape posts shall be safely secured to the balcony or brackets, forming the support of a substantial and ornamental balustrade to be surmounted by a suitable steel hand-rail....inches above the floor-level.

HEMISPHERICAL BOTTOM.

The bottom of the reservoir shall be riveted to the girder and shall be formed of special curved steel plate not less thaninch thick and a circular dished steel head of....inch diameter of like thickness, and so fashioned that when riveted together the surface will form a hemisphere.

INLET PIPE AND CONNECTIONS.

The lowest point on the hemispherical bottom shall be tapped and properly reinforced for connection with a standard expansion cast-iron joint of.....diameter and provided as an inlet for the cast-iron bell and spigot supply main, which shall extendfeet vertically to and terminate in a standard cast-iron foot bend supported by a substantial.....masonry pier.

The vertical supply pipe shall be further sustained by plate steel collars, secured to...inch radial rods, attached to each tower leg in its horizontal plane and at each panel-point.

(When climatic conditions render boxing or frost-proofing necessary, insert the following: About the vertical supply main a frost-case.....in diameter shall be provided. It shall consist of.....sections of.....inch plate, riveted to form a steel tube, with horizontal end flanges of..... inch angles. In the plane of each set of horizontal tower struts (except when a bottom tie strut is used) the pipe shall be braced by means of.....inch collars, secured to...inch horizontal radial rods extending to each tower post at its panel-point. The frost-case shall extend the entire length of the vertical supply pipe and shall rest upon the pier supporting the foot-bend.)

The cast-iron pipe, foot-bend, expansion-joint (frost-case), and ties shall be included in the cost of the water-tower.

MATERIALS.

All material intended to be used in the construction of this water-tower shall be the product of some well-established and reputable mill.

All tank plates and principal parts shall be manufactured by the open-hearth process and the reduction of the metalloids shall be insisted upon to the following maximum percentages in the finished product:

Acid process:	phosphorus.....	.08%
Basic	“ “04%

Drillings for chemical analyses may be taken either from test pieces or from the finished product.

Plate steel shall have an ultimate strength of 60,000 lbs. per square inch, with allowable variation of 5000 pounds either way,

as determined from a standard test-piece cut from the finished material.

Cold and quench bends 180 degrees flat on itself without fracture on outside of bent portion.

Broken samples must show a silky fracture of uniform color.

Punched rivet-holes, pitched two diameters from a sheared edge, must stand drifting without cracking the material until the diameter is one-third greater than the original hole.

The ultimate strength for structural steel shall be the same as specified for plate metal.

Finished bars shall be free from injurious seams, flaws, or cracks and shall have a workmanlike finish.

Test-pieces of full-size cross-section shall bend, either hot or cold, 180 degrees around a two-inch pin without cracking on the convex surface.

The ultimate strength of rod and rivet steel shall be from 48,000 to 58,000 lbs. per square inch.

Test-pieces shall bend 180 degrees flat on themselves without fracture on outside of bent portions.

The rivets to be used in this structure shall be the output of a manufactory having a reputation for a superior product, and the manufacturer's test of rods shall be accepted as sufficient by the engineer, but rivets taken at random from any shipment must successfully withstand any usual and reasonable test that may be ordered by the engineer prior to their use.

All rods requiring threading shall be properly "upset," and rods, nuts, turnbuckles, or clevises must be threaded to the U. S. standard.

Pins shall be of material of superior quality and shall be accurately turned.

INSPECTION.

An expert inspector shall be selected by the engineer for the purpose of testing the materials proposed to be furnished, and

the expense of mill and laboratory tests shall be paid by the contractor and must be included in the price bid for this water-tower.

From each lot of materials offered, one or more samples will be selected by the inspector for testing, and all pieces intended to be used in the work shall have the number representing the melt from which this material has been rolled clearly stamped upon them, and the absence of such numbers shall be deemed sufficient cause for rejection.

Each melt of steel must be represented by test, and when required, tests shall be made of the different sizes and shapes from the same melt. Chemical analysis of borings taken from each shall be made to determine the amount of phosphorus and sulphur in the material proposed to be furnished.

Allowance for variation in weight shall be made by the inspector in accordance with the standard adopted by the American Steel Manufacturers' Association.

Manufacturers shall afford inspectors the usual facilities for the examination of materials, which to pass a surface inspection must appear to be a good merchantable product, sound and well finished.

Materials that have been warped or buckled shall be rejected.

If, for lack of transportation or other cause, delay in shipment occurs, the material must be safely stored and protected.

After leaving the mill, the right is reserved to appoint inspectors both at the shop and in the field to approve materials and constructive methods, but the wages of such employes shall not be assessed against the contractor.

STRESSES.

The thickness of the plates composing the cylinder and the bottom shall be such as to sustain the stresses produced by their weight and contents, with a factor of safety of at least four (4)

when computed by a recognized formula, with proper allowance for decreased resistance after punching and riveting, but no plate shall be less than one-quarter ($\frac{1}{4}$) inch thick.

Rivets shall be provided to resist the entire stresses transmitted, and shall be of sufficient size and number to present ample resistance to shearing and afford bearing area sufficient to prevent the liability of crushing the metal about the rivet-holes. The bearing value of rivets shall be assumed at not less than twelve thousand (12,000) pounds per square inch when the area considered is the diameter of the rivet-hole multiplied by the thickness of the metal. The pitch of the rivets shall equal the net section of plate. The ratio of the strength of the riveted joint to that of the solid plate shall not be less than the following:

Single-riveted joint	56%
Double-riveted joint.....	70%
Triple-riveted joint.....	75%
Double-riveted butt-weld joint.....	87%

Tensile and shearing strains on rods and pins shall not exceed twelve thousand (12,000) pounds, and bending strains shall not exceed twenty-five thousand (25,000) pounds per square inch when the centre of bearings of the strained members are taken as the points of application of these stresses.

The stress in the circular girder shall be assumed as due to the entire weight supported and the resultant horizontal thrust at the top of the posts. The shear strain on the girder and the horizontal thrust on the lower flange ring shall not exceed ten thousand (10,000) pounds per square inch of metal.

The cover shall be designed to safely resist the assumed wind stress, but no cover-plate shall be less than three-sixteenths ($\frac{3}{16}$) inch thick, and shall be reinforced when necessary by radial rafters, tie-rods, or otherwise.

The external pressure of the wind shall be taken at and calculations made for not less than thirty (30) pounds per square foot as exerted upon the vertical diametral plane of the tank and exposed tower surfaces.

The tower shall be proportioned to sustain the combined load due to the weight of the water, the metal of the structure, and the assumed wind pressure and resulting stresses. Where the main posts connect to the tank-shell the posts shall be reinforced so that the area of section for a distance of thirty-six (36) inches below shall be equal to an area one and one-half ($1\frac{1}{2}$) times the area of the post.

The stresses shall not exceed fourteen thousand (14,000) pounds per square inch for members not exceeding ninety (90) times their least radius of gyration between supports, and for greater lengths the allowable unit stress shall equal twenty thousand (20,000) pounds minus seventy (70) times the length in feet divided by the least radius of gyration of the section in inches.

No main post shall exceed one hundred (100) times its least radius of gyration, and no other strut shall exceed one hundred and fifty (150) times the radius or such length that the fibre stress due to bending from its own weight shall exceed four thousand (4000) pounds per square inch of metal.

No shape weighing less than four (4) pounds per linear foot shall be used except for reinforcement of parts or for ornamental or unimportant features.

Columns shall be secured to steel base plate, reinforced with angle connections, and shall be designed to resist vertical shear stresses not exceeding ten thousand (10,000) pounds per square inch. The area or bearing value of the base plate shall be such that not more than four hundred (400) pounds shall be exerted upon the upper face of a monolithic capstone, transferring not more than one hundred (100) pounds per square inch to a supporting masonry pier, so proportioned that not more than tons per square foot shall be delivered to the subfoundations.

The overturning and resisting moment of the water-tower shall be calculated from the assumed wind pressure, resisted by the weight of the structure when empty, but anchorage shall in all cases be provided.

SHOP WORK.

As soon as received at the shop, all material shall be assorted and carefully and accurately laid out for punching, machining, shearing, and rolling.

Plates exceeding three-eighths ($\frac{3}{8}$) inches shall be planed to a bevel by machining; all other plates may be sheared.

Plates under five-eighths ($\frac{5}{8}$) inch may be punched with sharp and well-conditioned punch and dies away from the surfaces in contact. The punch shall be one-sixteenth ($\frac{1}{16}$) inch greater diameter than that of the rivet proposed to be used.

Plates having a thickness between five-eighths ($\frac{5}{8}$) inch and seven-eighths ($\frac{7}{8}$) inch must be punched to correspond to the diameter of the rivet to be used and afterwards reamed one-sixteenth ($\frac{1}{16}$) inch larger, while plates exceeding that thickness shall be drilled from the solid metal.

In general all bends in the metal must be made cold, especially in the case of the cylinder and bottom plates, but detail pieces may be bent hot without annealing.

If a steel piece in which the full strength is required has been partially heated, the whole must be subsequently annealed.

In laying out plates, lap-joints will be allowed only for connecting plates less than seven-eighths ($\frac{7}{8}$) inch thick; all other joints must be of the butt-strap type.

When "scarfing" is necessary, the temperature of the reheated metal shall not be more than would be necessary to ignite hard wood when placed in contact.

Flanging or bending shall be done by means of suitable rolls and without reheating. This process shall follow punching

and other machine work. Immediately after rolling, the several parts shall be cleaned and assembled and all irregularities shall be corrected.

Rivet-holes shall be made to coincide accurately by reaming.

Rivet-heads must be of uniform shape and size for the same size rivets throughout. They must be full and neatly finished and concentric with the rivet-holes. All rivets when driven must completely fill the holes, the heads being in full contact with the surface or counter-sunk when required.

Whenever possible, all rivets shall be machine-driven.

All portions of the work exposed to view shall be neatly finished and all surfaces in contact shall be painted with pure red lead and linseed-oil before they are permanently connected.

Columns and other "built" members shall, as far as practicable, be completely riveted at the shop, leaving only connecting points, drilled to templet, to be secured in the field. Important parts shall be plainly marked.

FIELD ASSEMBLY.

Upon arrival at the point of consignment, care shall be taken in unloading all material, and parts damaged in transit shall be rejected and promptly replaced. All material shall be properly protected until ready for use. In assembling the parts, drifting will be permitted only in exceptional cases and excentric holes must be reamed and larger rivets shall be used when required.

Rivet-calking will not be allowed and loose rivets must be cut out and replaced. Calking seams must be entrusted only to skilled workmen, using proper tools and exercising due diligence to prevent injury to the under plate. Parts inaccessible after erection, and including laps at joints, shall, immediately before being riveted, be given a substantial coat of pure red lead and linseed-oil.

TEST.

After the completion of the work the tank shall be filled with water and carefully tested, all leaks being noted and marked. After emptying, all loose rivets shall be cut out and replaced. Leaky joints shall be made absolutely tight by calking only, and all defective parts and workmanship shall be promptly corrected. Adjustable members shall be tightened when necessary, and undue settlement of the structure shall be remedied.

PAINTING.

Following the preliminary test of the work, all surfaces shall be thoroughly cleaned and freed from grease, dirt, detachable mill scale, and rust by the use of the hammer, chisel, or wire brush, and the entire surface shall be thoroughly dried.

The priming coat shall consist of a finely ground pigment, repellent to water and mixed with pure linseed-oil. It must be applied as thick as possible, compatible with satisfactory spreading. The paint shall not contain any volatile matter tending to chill the surface by evaporation, and at least twenty-four (24) hours shall elapse before the finishing coat is commenced.

The material selected for the finishing coat shall be one whose essential principle shall be that of an asphaltic varnish and whose preparation or manufacture shall be satisfactory to the engineer, and of such composition that the under or priming coat shall not be softened or acted upon in an injurious manner. The finishing coat shall be of a different shade of color from that of the priming.

DELAY IN COMPLETION.

In the event the contractor shall fail to complete the work in the time agreed upon in the contract, or in such extra time as may have been allowed for reasonable delays incident to the

work, the engineer shall compute and appraise the direct damages sustained by.....on account of the further employment of engineers, inspectors, or other agents, including all disbursements on the engineering account properly chargeable to the work. The amount so appraised and computed shall be deducted from any money due the contractor under his contract.

The decision of the engineer as to the appraisal of such damages shall be conclusive, final, and binding upon both parties.

In awarding contracts for water-towers, it is customary for the metal work and erection to be separated from the foundation work, the latter being usually more economically undertaken by a local contractor or by the general contractor, when the tower is an item of other constructive work, as, for instance, a complete water system.

Since the character of the foundations, including capstones, depends largely upon local conditions, and as this class of work is generally well understood, detailed specifications for foundations are consequently omitted. Attention is called, however, to the possibility of misunderstanding and of accident resulting from a division of responsibility, as evidenced by the failure of a water-tower hereinbefore mentioned.

CHAPTER XIV.

ARCHITECTURE AND ORNAMENTATION.

A STUDY of the record of stand-pipe accidents and failures shows conclusively the necessity for protecting such structures, especially in icy latitudes.

Were it not for such object-lessons directly appealing to the utilitarian sense, in view of the little that has been accomplished in the past, it would seem hopeless to direct the attention of corporations or even municipalities to the splendid opportunity for ornamentation and adornment offered by these necessarily conspicuous structures and sites.

If the need for surrounding steel stand-pipes with a masonry edifice can be demonstrated as a material element of their safety, there is a possibility that some ornamentation will suggest itself in the design of the masonry tower.

Whatever may be said of the past, there is to-day a distinct and growing tendency toward civic adornment, and an increasing willingness to make provision for the artistic along with the useful.

Dictated largely by a desire to advertise local importance and industry the great world's fairs have been far-reaching in imparting their lessons of the true and beautiful, embodied though they were in ephemeral creations.

Their æsthetic treatment of architecture, enhanced and embellished by sculpture and kindred arts, effective landscape design, with detail of floriculture, horticulture, and forestry, the effect of light, color, and the ornamentation possible through crystal jets, flowing cascades, and pulsating fountains, produced

a profound and permanent impression and a broadening of the artistic sense that has resulted in the formation of such societies and organizations as the American League of Civic Improvement, Architectural League of America, American Park and Outdoor Art Association, and numerous other like parent bodies, each with an ever-extending realm of influence. In effect, the movement is the American Renaissance, calling into life a dormant instinct implanted through divine purpose, prompting the beautifying of the ordinary and useful, until the instinct of the artist shall have entered into the conceptions of humbler artisans delving and fashioning the homely articles of commercial and domestic necessity, until as in those older days "the guilds of the painters and sculptors shall be fraternal to those of the weavers, the armorers, the brewers, and the bakers."

Until this awakening, a few individual efforts marked here and there a desire for more beautiful surroundings.

L'Enfant laid out our Federal capital upon broad and artistic lines, but only since the present century has his careful and loving efforts received their merited recognition; now a committee of noted artists and architects are devoting their talents toward building the city of his imagination.

Marvellous as has been the growth of industrial and scientific America during the past century in artistic cultivation and the æsthetic treatment of our surroundings, as a nation we are woefully behind those of the Old World. Picture the Venetian Campanile beside the wonderful church of San Marco and the superb palace of the Doges. Only a bell-tower, yet its fall in 1902 shook the world!

With this pride of Venice contrast the following:

From the water of a Southern seaport city the land slopes back to a commanding height, and upon its summit, surrounded by handsome homes, stately live-oaks, and overlooking a grand view of harbor shipping and inland country, there rises a gaunt steel stand-pipe, its faded sides tinged with yellow rust

streaks from innumerable seams, and toward its top the six-foot letters of a real-estate dealer's advertisement. Compare the Campanile, that peaceful home of hundreds of pigeons, and the uncrested stand-pipe, a favorite roosting-place for flocks of buzzards!

The systematic design and appropriate ornamentation of masonry structures belong to civil architecture, 'the art which so disposes and adorns the edifices raised by man for whatsoever use that the sight of them contributes to his mental health, power, and pleasure'; nevertheless, so insensibly do in many cases the art and science of architecture and engineering blend, that it is a desideratum if not a prerequisite for the professed engineer to understand and appreciate the principles of correct architecture and to be familiar with its fundamental truths.

Ruskin says there is but one grand style in the treatment of all subjects whatsoever, and that style is based upon the perfect knowledge, and consists in the simple, unincumbered rendering of the specific characteristic of the given object.

Gérôme, the great modern painter and critic, announces, "the fact is that truth is the one thing truly good and beautiful; and to render it effectively, the surest means are those of mathematical accuracy."

Whatever the subject, material, or means, they must appeal to the innate sense as appropriate to the object sought. Massive weight must be so supported that equilibrium be implied; it must be apparent without analytical investigation. An attempt to trick the imagination through deceptive artifices is fatal. Prison walls and fortress battlements should immediately convey their purpose in grim and forceful character; the ornamentation of such subjects by oriental minarets or fanciful friezes would be at once characterized as extraneous, a departure from the truth, and hence false to art.

Discussing the design of so simple a thing as a doorway, a recent writer emphasizes the true and false as follows: "Between

colonial days and the recent past, there was little praiseworthy in our entrances. With sudden wealth we treated huge blocks of stone as though they were of lace; gave fragile glass the air of protecting a fortress; erected towering pillars that guarded doll's house doors. Disdainful of harmony and proportion, we employed material in a way that was itself a lie. . . . Do not demand that the door shall tell of luxury within. You have the right to expect the old-time hinge, strong because it is not hidden; welcome because it is beautiful; locks, bolts, and nails that are not ashamed to be seen; doors that shall not be a source of pleasure to the present generation alone. Be prepared to appreciate harmony of design, even in iron, to note how stone and glass and bronze have beautified a necessity."

With architecture as with other arts and sciences there are simple, natural laws that must be understood; their logical development in architecture have created authenticated orders and styles, which attempt to pervert, modify, or amalgamate produces a lack of harmony, symmetry, and repose.

A proper perception of these truths would prevent many failures. Falling into this error, the celebrated architect, Christopher Wrenn, the designer of St. Paul's Cathedral, London, and many forceful and beautiful architectural examples of the seventeenth century, departed from the "Gothic rudeness" of splendid Westminster Abbey, and, attempting to introduce additional wings of "good Roman" style, perpetuated a failure as the result of an attempt to compel the union of opposite orders, classic in themselves, but unartistic and inharmonious in their combination.

Such deviation from the principles of correct architectural style are too abundant. Consider the design of one of the principal buildings of the Louisiana Purchase Exposition. Intended as a building for housing exposition exhibits, "it was argued that it should express externally as much friendly dignity as would be compatible with its ephemeral character; that it

would be incongruous to disguise this character under the garb of severe and classic forms which we associate with the most lasting architectural monuments of antiquity; and that, furthermore, being a part of the greatest exposition ever attempted, it should undoubtedly be novel, striking, and full of life."

Proceeding upon these lines, a building was designed concerning which its architect says: "Some have attempted to classify it as an example of the 'nouveau'; but when I recently noticed an English art critic say, in protesting against its invasion of Great Britain, that this 'nouveau' art is 'a malady the pernicious virus of which becomes more acute the further it travels,' I feel a strong personal solicitude for a properly conducted baptismal ceremony. Let us therefore name it 'Secession Architecture.' Perhaps I will have to explain what secession architecture is, if the name should not make it quite clear. It means architectural liberty and emancipation with a strong plea for individuality. It is a breaking away from conventionality of design; it is more an architecture of feeling than formula. Editorially commenting upon the building and the explanation of its author, one of the technical papers says: 'If *we* were to engage in speculation as to the style of architecture which this remarkable design represents, we would suggest, as Ionic pilasters and Doric columns unite to support a Spanish roof surmounted by a dome of Renaissance effect, while Egyptian monoliths guard the entrance to a doorway ornamented by Grecian fretwork, and a number of additional styles have evidently 'felt' their way into the composition, it would be more appropriate to call it mongrel architecture. To attempt to succeed by departing from all recognized laws of artistic design may result in 'novel and striking forms, but nothing can be produced in this way which will receive the world's admiration as did the famous 'White City' on the shore of Lake Michigan."

Possibly with the memory of some such atrocity of design or with prophetic vision, a few years since the *Engineering Record*

asked for competitive designs of water-towers and power-stations, and referring to builders of water-works, editorially announced: "The projectors of such enterprises should not erect structures placed on hill-tops to be an offence to the eyes of this and future generations.

"The additional expense of beautifying these structures need not be great if the design and execution be entrusted to competent architects. The necessary isolation and altitude of these buildings is at once a suggestion of the availability of the site as a pleasure-ground, the tower itself constituting an admirable central feature readily adapted to the purposes of a lookout.

"In the case of private ownership it should be borne in mind that in the bestowal of such franchises the community gives, without price, something of substantial value, which might gratefully be in part repaid by the avoidance of an absolutely ugly sore on the landscape at least, if not by throwing open to public enjoyment something of the nature of a public park."

In passing judgment upon a number of prize designs, a well-selected committee of architects and engineers say in part: "The conditions under which we were invited to act were, first, adaptability for the purpose desired; second, architectural design; third, economy in the treatment; fourth, rendering of the drawings. In interpreting these conditions we were led to believe that the general scope and intent of the competition would lead to precedence being given to adaptability rather than to merely artistic expression in the design, and that in considering the merits of the various designs submitted, other things being equal, the design given the higher place should be based upon ordinary and feasible conditions, such as might arise in the average community, rather than upon exceptional or unusual conditions, even if exceeding in artistic merit.

"We regret that so few designs were presented in which artistic effect had been sought by simple means, rather than by costly and formal architectural devices. It must frequently

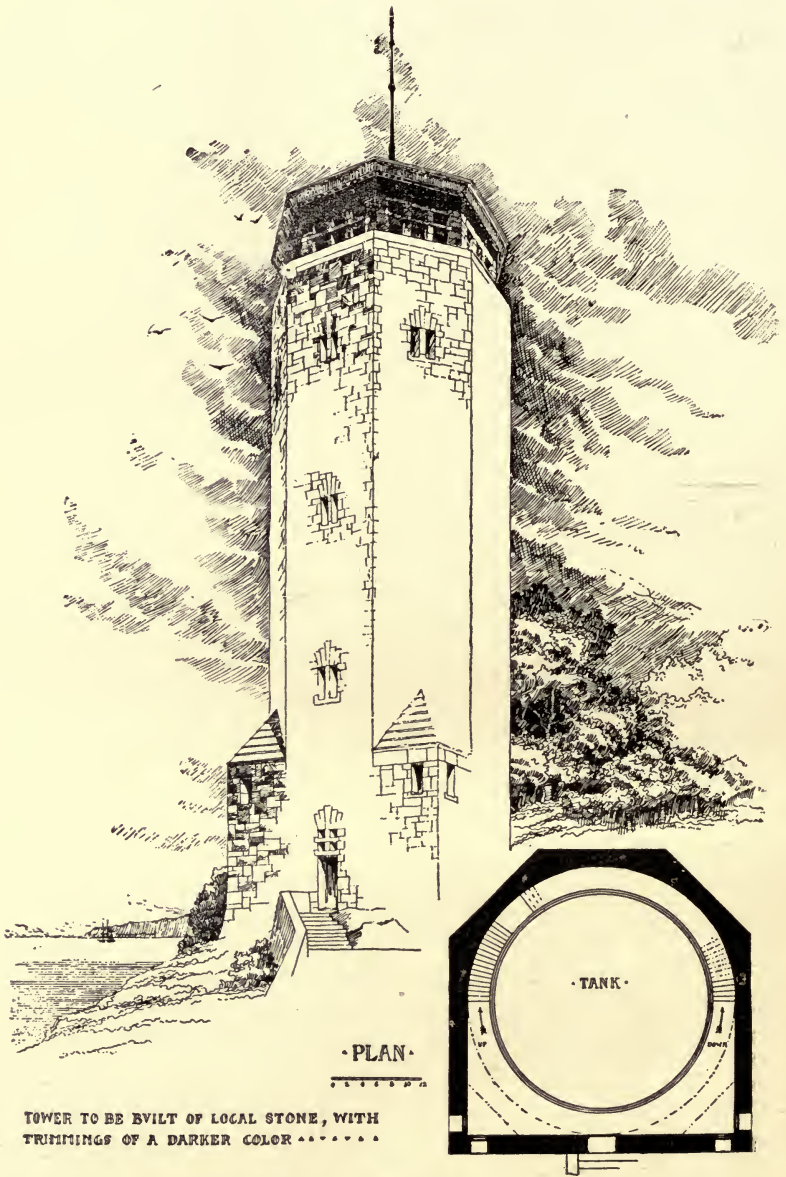

FIG. 60.—“ENGINEERING RECORD” FIRST PRIZE, WATER-TOWER DESIGN.

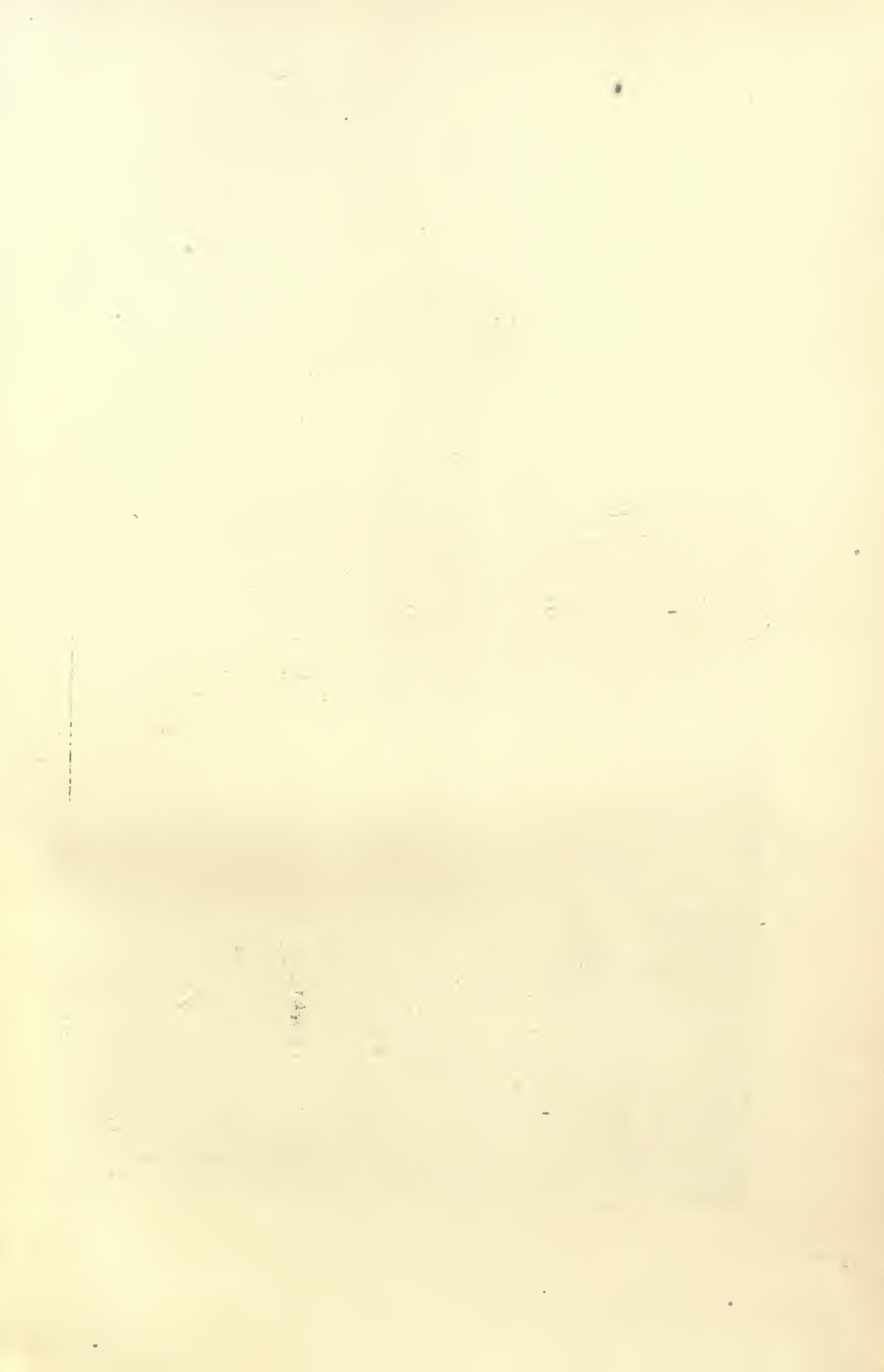



FIG. 61.—ST. LOUIS WATER-TOWER.

(To face page 317.)

occur in the execution of work of this kind that the money at command is limited, and the simplest possible architectural expression is the only thing possible. Consistent with this fact, we have awarded the first prize to a design which would give valuable suggestion to communities of moderate means called to erect structures of this sort."

A recently constructed masonry structure about a steel stand-pipe and a part of the St. Louis water-works system is a fair example of possibilities in this connection. As may be seen from the accompanying illustration (Fig. 61), the circumscribing edifice is costly, massive, and imposing, and ornamental to the vicinity in which it has been erected. As a whole, its effect is pleasing, but it is to be regretted that a more appropriate roof design had not been provided. The bell-shaped superstructure has a "beehive" appearance, which detracts from an otherwise fine type of water-tower construction.

A steel water-tower is a much more promising problem for architectural beauty than its companion, the cylindrical stand-pipe, since in that direction opportunity is limited to correct construction and taste displayed in detail and painting. A worthy example of what may be done with such a structure is the water-tower designed by Prof. Marston for the Iowa State College, hereinbefore mentioned and illustrated in Fig. 62. Its purpose is unmistakable, its lines are graceful, and the effect altogether substantial and pleasing. Analogous to the limited possibility of architectural effect in water-tower construction is the modern steel bridge, concerning which Mr. Alfred P. Boller, M. Am. Soc. C. E., in his work on "Highway Bridges," says:

"In the true sense of the term architecture, unadorned construction is as much a part of architecture as the more popular idea that it simply covers the art of producing pleasing effects. A man cannot be a good architect before he is a good constructionist, no matter how dexterous he may be in devising graceful forms or artistic in his selection of colors. In bridge-building

there is little room for artistic architecture, and any pleasing effect produced must grow out of consistency of design and a thorough knowledge of the peculiarities of materials of construction and color. To an educated person, correct construction always produces a sense of satisfaction, for in it is involved the idea of proportion and appropriateness for the service to which it is put. Concealment of constructive forms, by mouldings, panels, or other devices, to suggest something else than what the construction really is, is vulgar as well as dishonest. To construct a girder bridge and give it the *appearance* of being an arch illustrates what is here meant by falsity of architecture, specimens of which more than one of our public parks contain. Possibly to bridges more than to any other class of public works does the Ruskinian axiom (which cannot be repeated too often) apply: 'Decorate the construction, but not construct decoration.' Such a principle conscientiously kept in view cannot but result in else than good work. Its violation results in a senseless fraud demoralizing to the taste of the community where such violations may occur. Public works, in a certain sense, play a part in the education of a people, and their authors and builders have consequently to that extent a responsibility in addition to the mere utilitarian idea of endurance and safety. The ideas herein advanced are not novel ones by any means; but they cannot be enforced too often, when in this boasted age of culture and civilization a community will permit the huge architectural fraud of the Fairmount Bridge over the Schuylkill at Philadelphia, and hardly yet completed. Constructively, this bridge, with its double tier of floors, spanning the Schuylkill in a single stretch of 340 feet, is a monument to its designer and an honor to American engineering. Instead of letting the enormous trusses stand in all their grandeur, depending wholly upon judicious painting and the design of the cornices and railings, etc., for their æsthetic effect, thousands of dollars have been spent in actually covering up the trusses to a great extent with sheet iron, forming an arcade



FIG. 62.—AMES, IOWA, STEEL WATER-TOWER.

(To face page 318.)

as it were of great massiveness by arching between the posts of the trusses, the arches springing from large Roman sheet-iron capitals about *half-way* down the posts. The result is that at a little distance the spectator beholds an arcade without any visible means of support for a distance of 340 feet. To be thoroughly consistent, the architect (Heaven save the name!) of this constructed 'decoration' should have at least sanded his sheet iron when painted and marked out in strong lines the joints that masonry of similar forms suggests.

"About one mile north of this bridge a noble structure spans the Schuylkill, the Girard Avenue Bridge, as it is called. As an *engineering* accomplishment it stands in no comparison with the bridge at Fairmount, the spans being much smaller, and only a single roadway (of paved granite) is carried on the upper chord, it being a 'deck bridge.' *Architecturally* it is certainly one of the finest, if not the finest, bridges in America; while in the same sense the Fairmount bridge is the worst, and probably the worst in the world. The Girard Avenue is an example of pure *decorated construction*, and the writer is aware of no place in this country where the principles for which he has been contending can be so well illustrated as in the case of these two Philadelphia bridges."

INDEX.

ARCHITECTURE:

- Competitive Water-tower Designs, 315.
- Examples of Water-tower Design, 317.
- Incongruous, 313.
- Ornamentation of Metallic Structures, 317.
- Ornamentation, opportunity for, 316.
- Style in, 312.
- Tendency toward Improved, 311.

CAPACITIES:

- Cones, 111.
- Cylinders, 111.
- Hemispheres, 112.
- Segment of Sphere, 112.
- Tanks, 92-99, 163.

COLUMNS:

- Gordon's Formula, 105-106.
- Sections, 216.
- Straight-line Compression Formula, 107-108.
- Stresses in, 135-138, 213-215.

DETAILS:

- Anchorage, 173, 203-205, 218-219, 236-241.
- Bearing-plate, 218.
- Bed-plate and Connections, 170.
- Balcony, 200.
- Circular Girder, 188-191, 207-209.
- Connections, 202.
- Discussion concerning, 171-172.
- Estimating Quantities, 205-207.
- Frost-proofing, 200.

DETAILS:

- Graphic Design, 205.
- Ladder, 198-199.
- Supporting Tower, 192-194, 196, 216-217.
- Tank Bottom and Connections, 184-188.
- Tank Cover, 197-198.
- Trolley Rail, 198.
- Wind-bracing, 203.

ERECTION:

- Delivery of Materials, 281.
- Foundations, 208.
- Field Assembly, 282-284.
- Field-riveting, 285-286.
- Inspection, 284.

FAILURES:

- Atlantic City, N. J., 16.
- Classification of, 51.
- Cortland, N. Y., 15.
- Elgin, Ill., 20.
- Fairhaven, Mass., 16, 179-184.
- Garden City, Kan., 14.
- Griswold, Ia., 11.
- Lena, Ill., 12.
- Lincoln, Neb., 28.
- Normandy Heights, Md., 30.
- Red Oak, Ia., 12.
- Waco, Tex., 16.

FORCES:

- Bending and Resisting Moments, 101.
- Equilibrium, 81.
- Hydrostatic Pressure, 88-90, 162.
- Moment of, 80.
- Moment of Inertia, 101-102.
- Modulus of Elasticity, 102-104.
- Overturning Moment, 211.
- Resistance to Overturning, 81-88, 219.
- Resistance Offered by Materials, 90-91.
- Radius of Gyration, 104.
- Tension on Joints, 212.
- Tortion Moment, 210.

FORCES:

Wind-pressure, 82-84, 133, 209.

FOUNDATIONS:

Bearing Values, 224-226.

Clay, 221.

Concrete, 232-233.

Dry Sand, 223.

Designing, 236-242.

Masonry, 226-232.

Maximum Pressures, 233-235.

Preparation of, 280-281.

Quicksand, 224.

Rock, 220.

Stresses in, 139-140.

INSPECTION:

Steel, 74-78, 284.

MASONRY:

Brick, 229-231.

Concrete, 232-233.

Stone, 226-229.

Weights of Stone, 242.

Weight of, 236.

PAINT:

Asphaltic Varnish, 262-265.

Application of, 265-268.

Average Surfaces Covered by, 275.

Chemical and Galvanic Action, 245-249.

Discussion of, 243-244.

Films, 255-258.

Iron Rust, 244.

"Japanned" Plates, 254-255.

Mill-scale, 246-247.

"Oxidized" Plates, 254.

Pigments, 258.

Preparation for, 250-253, 279.

Practical Considerations, 255.

Protective Coverings Discussed, 268-274.

Red Oxide of Lead, 258-260.

Zinc Coating, 253.

RIVETING:

- Double-riveted Joint, 147-148.
- Double-welt Butt-joint, 149-152.
- Field Riveting, 285-288.
- General Practice in, 142-143.
- Joint Efficiency, 144-169.
- Pitch of, 155.
- Size of, 156-161.
- Single-riveted Joint, 144-147.
- Steel Rivets, 154.
- Triple-riveted Joint, 148-149.

SHOP PRACTICE:

- Assembly, 279.
- Cleaning and Priming, 279.
- Laying Out, 276.
- Machining; Punching and Rolling, 277-278.

SPECIFICATIONS:

- Application of Paints, 265.
- Brick Masonry, 229.
- Concrete, 232.
- Cleaning Metal, 250.
- General Discussion of, 289.
- International Association, 47.
- Manufacturers' Standard, for Steel, 45.
- Repainting, 268.
- Steel, Physical, 68.
- Steel, Chemical, 73.
- Stone Masonry, 228.
- Stone Monoliths, 241.
- Stand-pipes, 8, 10, 11, 12, 15, 16, 20, 28, 30, 298-308.

STEEL:

- Bessemer, 40.
- Chemical Specifications for, 73-74.
- Comparative Cost of, 58.
- Comparative Strength of, 59.
- Difference from Iron, 36-38.
- Distinguishing Terms of, 65-68.
- Effect of Heating, 39.
- Effect of Phosphorus, 42-44.
- Inspection of, 74-78.

STEEL:

- Manufacturers' Specifications for, 45-47.
- Open-hearth, 41.
- Report of International Association, 47-49.
- Relative Merits of, 52-58.
- Rivets of, 154.
- Stand-pipes of, 5-9.
- Suitable Grades of, 61-65.
- Specifications for, 68-73, 301.
- Thickness of Plates of, 91, 166-167.

STRAIN-SHEETS:

- 163-165, 206.

STRESSES:

- Compression, 79.
- Explanation of, 79, 109.
- Foundation, 139-140, 215, 233-236.
- Gravity, 109.
- Horizontal, 132-133.
- In Cylinder, 112-114, 134.
- In Cone, 114-116.
- In Circular Girder, 120-127, 207-209.
- In Joint, 117-120, 212.
- In Posts, 127-128, 213-215.
- In Segment of Sphere, 116.
- In Ring at Top of Posts, 130-132.
- In Tower, 135-139, 213-215.
- Resulting from Horizontal Thrust at Top of Posts, 128-129, 210.
- Shear, 79-80.
- Tension, 79.
- Wind, 133-139.

WATER-WORKS:

- Ancient, Examples, 1.
- Gravity Systems, 2.
- Reservoirs for, 3, 5, 10, 162-163, 177.





fact
res 5

RETURN TO the circulation desk of any
University of California Library

or to the

NORTHERN REGIONAL LIBRARY FACILITY
Bldg. 400, Richmond Field Station
University of California
Richmond, CA 94804-4698

ALL BOOKS MAY BE RECALLED AFTER 7 DAYS
2-month loans may be renewed by calling
(510) 642-6753

1-year loans may be recharged by bringing books
to NRLF

Renewals and recharges may be made 4 days
prior to due date

DUE AS STAMPED BELOW

OCT 18 1995

AUG 16 1996

JUN 28 1996

RECEIVED

MAY 08 1996

CIRCULATION DEPT.

20,000 (4/94)

FORM NO. DDD

BERKELEY, CA 94720

©s

LD 21-50m-1,'83

YC 13201

U.C. BERKELEY LIBRARY



C005279995

T D 454

1907

195052

Hazlehurst

